



BLOOM

■ DESIGN GUIDELINES

APRIL 15, 2026

MULBERRY METROPOLITAN DISTRICT

TABLE OF CONTENTS:

1.0	INTRODUCTION	4
1.1	Purpose	
1.2	Community Vision	
1.3	Relationship to other plans and criteria	
1.4	Architectural Review Committee	
2.0	LAND USE.....	6
2.1	Land Use Plan	
3.0	ARCHITECTURAL CHARACTER	8
3.1	General Character & Product Types	
3.1.1	Traditional Single Family	
3.1.2	Alley-loaded Single Family (With or Without) Side Yard Use Easements	
3.1.3	Paired Homes	
3.1.4	Townhomes	
3.1.5	Apartments / Senior Housing / Multi-family / Condo	
3.1.6	Cottages	
3.2	Typical Improvements	
3.3	Architectural Review Committee Procedures	
4.0	LANDSCAPE STANDARDS	22
4.1	Public / Open Space Landscape	
4.2	Private Landscapes	
4.2.1	Front Yard Landscape Requirements	
4.2.2	Rear/Side Yard Landscape Guidelines	
4.2.3	Synthetic/Artificial Turf Requirements	
4.2.4	Xeriscape Requirements	
4.3	Side Yard Use Easements	
4.4	Landscape Lot Typicals, Maintenance, & Required Planting	
4.4.1	Single Family Detached Front and Side Load	
4.4.2	Single Family Detached Rear Load	
4.4.3	Front and Side Load Paired Homes	
4.4.4	Alley Loaded Paired Homes	
4.4.5	Cottages	
4.5	Bloom Signature Plant List	
5.0	FENCING	44
5.1	Permitted Fencing	
5.1.1	3-Rail Fence	
5.2	Fencing Setbacks	
5.3	Fencing Standards	
5.4	Pet Areas	
5.5	Railroad Fence Types	



6.0 DEVELOPMENT AND BUILDER SIGNAGE50

- 6.1 Sign Locations
- 6.2 Builder Signage

7.0 POLLINATOR RECOMMENDATIONS.....52

- 7.1 Concept Narrative and Significance
- 7.2 Installation
- 7.3 Maintenance
 - 7.3.1 General
 - 7.3.2 Recommendations for Private Landscapes
 - 7.3.3 Parks, Open Space and Trail Corridors
 - 7.3.4 Public Rights-of-Way
 - 7.3.5 Aria Corridor
- 7.4 Additional Resources

1.0 INTRODUCTION:

1.1 PURPOSE

These Design Guidelines are established to ensure the overall development quality is maintained during the final planning and design of Bloom, and maintained after design and construction. They are intended to promote design excellence by encouraging builders to explore and expand their range of architectural styles and methods when building residential products. These guidelines are intended to promote creativity and incorporate the flexibility necessary to achieve the diverse, yet cohesive community planned for Bloom. Creativity and excellence in design will be the primary criteria for receiving approvals during the architectural review process. The aim of these guidelines is not to provide prescriptive “standards” or “requirements” that will only impair the architect/builder from being able to achieve the high level of design desired for this community. Rather, these guidelines are meant to encourage excellence in design and are not intended to be interpreted as strict requirements.

1.2 COMMUNITY VISION

Bloom is a new master-planned community incorporating a range of uses including but not limited to residential and commercial properties, trails, and a variety of parks and open spaces. One of the foundational ideas behind the Bloom plan is a diverse mix of residential housing within dynamic, walkable neighborhoods. Characterized by front porches, a variety of pocket parks and gathering spaces, the design of Bloom is intended to allow for serendipitous encounters that will foster individual relationships and a closer community.

To help make the community vision a reality, land use standards are in place to create a compact, walkable community with a diversity of housing types that are viable given current and anticipated housing trends. This generally means more compact lots with less private yard space to maintain, while simultaneously providing enhanced public open space for recreation. The Modified roadway standards in Bloom serve to efficiently accommodate the integration of a range of residential lot types, sidewalks, trees lawns, vehicles, pedestrians, and bicyclists.

Multiple types of residential development are anticipated at Bloom including, but not limited to, front-loaded single-family lots, alley-loaded single-family lots, cottage homes, townhomes, alley-loaded paired homes, multi-family, condos, and accessory dwelling units. All alley-loaded products either front on streets or greenways.



1.3 RELATIONSHIP TO OTHER PLANS AND CRITERIA

These Design Guidelines serve as the basis for guiding each builder’s proposal for architectural design of the structures and other lot improvements, and ensuring conformance with the overall intent of the Bloom master planned community.

These guidelines do not modify other applicable Federal, State, and local codes and ordinances, but should be used in conjunction with these regulations. Use of property and improvements to property must comply with applicable building codes and other governmental requirements and regulations.

Refer to the approved Mulberry and Greenfields PUD Master Plan for site-specific design standards.

The Metro District and/or sub-associations may develop additional standards, as applicable (e.g. condos). Standards for Accessory Dwelling Units (ADUs) will also be developed by the Metro District and will be modified from time to time.

1.4 ARCHITECTURAL REVIEW COMMITTEE

All new development within Bloom is subject to review by the Architectural Review Committee (ARC) for conformance with these Design Guidelines as well as those set forth in the Master Declaration of Covenants, Conditions, and Restrictions (CC&R’s) for the Bloom Metropolitan District. Homeowners and Developers are strongly encouraged to meet with the ARC early in the design process to ensure conformance with the Bloom theming.

The review process will consist of the following:

1. Submit plans
2. Committee Review
3. Comments
4. Plan Adjustments
5. Approval/Denial

For a more detailed look at the Architectural Design Committee design review process refer to Article 2 of the Mulberry Metropolitan District CC&R’s.

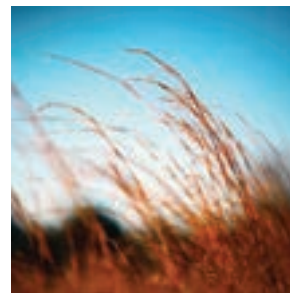

2.0 LAND USE:

2.1 LAND USE PLAN



Note: Image is conceptual and shown for illustrative purposes only. Land Use Plan is subject to change.

The Land Use Plan shows the conceptual design for Bloom, including the general arrangement of various housing types. Bloom includes traditional single family detached front-loaded homes, single family detached alley-loaded homes, paired rear-load homes, townhomes, multi-family apartments, and cottages. The neighborhood plan will include several parks, to be designed, built, and maintained by the District.



APPROVED PUD PLAN



Note: Refer to approved Mulberry and Greenfields PUD Master Plan for District Standards including Primary Permitted Uses within each District boundary.

3.0 ARCHITECTURAL CHARACTER:

3.1 GENERAL CHARACTER & PRODUCT TYPES

Architectural styles shall be Colorado vernacular, possibly including but not limited to Craftsman, Prairie, Farmhouse, and Contemporary Transition (this includes contemporary versions of the previous styles). Present day interpretations of traditional styles are encouraged. Homes should be different than, but compatible with, the neighboring homes. Duplicate floor plans, elevations, or color schemes shall not be allowed on adjacent lots or on lots across the street from each other. Building mass should provide interest and depth.

**The photos shown below are for illustrative purposes only and do not necessarily reflect the final design of the homes at Bloom.*

3.1.1 TRADITIONAL SINGLE FAMILY

1. A variety of architectural styles are permitted, including craftsman, farmhouse, prairie, or contemporary transition.
2. Primary body colors will be subtle earth tones, including, but not limited to, blues, grays, browns, taupes, and greens.
3. Color transitions/changes will be used to highlight changes in massing, form, and materials.
4. Bold, vibrant colors will be used in limited and select accent areas (e.g., front doors)
5. No adjacent buildings or lots directly across from each other will utilize similar color schemes.



3.1.2 ALLEY-LOADED SINGLE FAMILY (WITH OR WITHOUT) SIDE YARD USE EASEMENTS

1. A variety of architectural styles are permitted, including craftsman, farmhouse, prairie, or contemporary transition.
2. Primary body colors will be subtle earth tones, including, but not limited to, blues, grays, browns, taupes, and greens.
3. Color transitions/changes will be used to highlight changes in massing, form, and materials.
4. Bold, vibrant colors will be used in limited and select accent areas (e.g., front doors).
5. No adjacent buildings or lots directly across from each other will utilize similar color schemes.



3.1.3 PAIRED HOMES

1. A variety of architectural styles are permitted, possibility including craftsman, farmhouse, prairie, or contemporary transition.
2. Primary body colors will be subtle earth tones, including, but not limited to, blues, grays, browns, taupes, and greens.
3. Color transitions/changes will be used to highlight changes in massing, form, and materials.
4. Bold, vibrant colors will be used in limited and select accent areas (e.g., front doors).
5. No adjacent buildings or lots directly across from each other will utilize similar color schemes.



3.1.4 TOWNHOMES

1. A variety of architectural styles are permitted, possibility including craftsman, farmhouse, prairie, or contemporary transition.
2. Primary body colors will be subtle earth tones, including but not limited to, blues, grays, browns, taupes, and greens.
3. Color transitions/changes will be used to highlight changes in massing, form, and materials.
4. Bold, vibrant colors will be used in limited and select accent areas (e.g., front doors).
5. No adjacent buildings or lots directly across from each other will utilize similar color schemes.



3.1.5 APARTMENTS/SENIOR HOUSING/MULTI-FAMILY/CONDO

1. Apartments are permitted within Bloom in the locations indicated in the Mulberry & Greenfields PUD Master Plan.
2. Any condominiums or apartments will be designed with a character that is complementary to the overall character of Bloom.



3.1.6 COTTAGES

3. A variety of architectural styles are permitted, including craftsman, farmhouse, prairie, or contemporary transition.
4. Primary body colors will be subtle earth tones, including, but not limited to, blues, grays, browns, taupes, and greens.
5. Color transitions/changes will be used to highlight changes in massing, form, and materials.
6. Bold, vibrant colors will be used in limited and select accent areas (e.g., front doors).
7. No adjacent buildings or lots directly across from each other will utilize similar color schemes.



3.2 TYPICAL IMPROVEMENTS

Certain portions of the community may have additional rules and regulations which are applicable to specific housing product types.

The following list contains a wide variety of typical types of improvements which homeowners frequently consider installing. Unless otherwise specifically stated, drawings and/or plans for a proposed improvement must be submitted to the ARC and written approval of the ARC obtained PRIOR TO commencement of construction of the improvement. If a proposed improvement is not specifically listed below, the homeowner, architect, builder, or landscape designer must make a request to the ARC for review and approval. Please ensure the most current revision of the guidelines are being used, as they can change from time to time as allowed by Mulberry Conditions, Covenants, and Restrictions (CC&R's). Submittal fees may be adjusted from time to time by the ARC. ARC approval is required for, but is not limited to, the following typical improvements: The most recent set of Design Guidelines is available through the Metropolitan District website. The most recent PUDs and/or other governing entitlement documents are available through the local jurisdiction.

ACCESSORY DWELLING UNITS (ADU'S)

Accessory dwelling units must be the same material and color as the exterior of the home, unless otherwise approved by the ARC. ADUs are permitted on lots identified within approved City of Fort Collins development plan sets. ADUs on other lots must follow City's review and permitting procedures, per the Mulberry and Greenfields PUD Master Plans. ADUs are allowed on lots identified within the final FDP or BDR plan set on file with the City. ADUs on other lots must follow the City's review and permitting procedures, per the PUD.

ADDITIONS AND EXPANSIONS

An addition or expansion of the home is an increase in the size of a building brought about by constructing additional usable building space to the side/s or top of an existing structure. Examples include room additions, pop-tops, three (3) or four (4) season enclosed patios, balconies, porch covers, or attached garages. All additions and expansions must be approved by the ARC and meet the following guidelines:

- > Shall match or closely compliment the materials and colors used on the home.
- > Must be constructed entirely within allowable building setbacks as established by the City.

ANTENNA/SATELLITE DISHES

Satellite Dishes or Antennas that do not require ARC approval:

- A. an antenna designed to receive direct broadcast satellite services, including direct-to-home satellite services, that are one (1) meter/ thirty-nine inches (39") or less in diameter.
- B. an antenna designed to receive video programming services via multi-point distribution services, including multi-channel multi-point distribution services, instructional television fixed services, and local multi-point distribution services, that is one (1) meter/ thirty-nine inches (39") or less in diameter or diagonal measurement; or
- C. an antenna that is designed to receive television broadcast signals not taller than thirty-five feet (35').



The District does ask that owners try to keep such dish or antenna and related cables contained within the structure or otherwise screened from public view to the extent feasible, so long as such placement does not substantially degrade the reception of the signal. If the dish or antenna or the cables cannot be screened from public view to get reception, the cables in public view need to be painted the same color as the home. Satellite dishes larger than one (1) meter/thirty-nine inches (39”) in diameter or antennas taller than thirty-five feet (35) are not permitted in the Community.

ARBOR / PERGOLA (not permitted for condos or multi-family products)

An arbor is a free-standing arch and a pergola is a feature with an open lattice that may or may not be attached to the building, which both provide shade and/or aesthetic feature with or without climbing plants. Occasionally, a temporary seasonal fabric cover is incorporated in the pergola – see guidelines for TEMPORARY SHADE COVER. An arbor or pergola can be permitted if approved by the ARC which meets these guidelines:

- > Constructed on the individual property at a max height of ten feet (10’).
- > Complements the house color and materials, is treated to prevent weathering, and arbor/pergola are encouraged to be stained.
- > Permitted in rear yard only

ARTIFICIAL TURF

See Landscape Requirements and Guidelines.

AWNINGS OR EXTERIOR SHADES

An awning is a roof like shelter extending above a window, door, deck, or patio and is commonly made of canvas or a similar durable material. Exterior shades look and feel like interior shades but are used on patios or decks to shade in peak sun times of day. Awnings or exterior shades are permitted on homes for environmental purposes. ARC approval is required PRIOR TO installation and the awning or exterior shade needs to adhere to the following guidelines:

- > Professionally installed
- > Color that compliments the home
- > Height shall not exceed ten feet (10’h) over patio or deck
- > Retractable or removable

BARBECUE/GAS GRILLS

Barbecue grills, smokers, etc. shall be maintained screened from view. Any applicable governmental fire/smoke bans shall be adhered to. Refer to condo association or other governing entity regulations for applicability within condo and/or multi-family housing.

BASKETBALL HOOPS/OTHER PORTABLE PLAY EQUIPMENT

Permanent basketball hoops and other permanent play equipment may be permitted but shall be approved by the ARC. All play equipment shall abide by municipal code. Basketball hoops and other portable play equipment to include but not limited to tether ball and soccer nets are prohibited on streets, sidewalks, and alleys due to safety issues.

PORTABLE HOOPS:

Approval is not required provided the following guidelines are met: Hoops must be mechanically sound, clean, and well maintained. For safety and access reasons, hoops may only be used in the owner's backyard or on the owner's driveway and placed so that play does not extend onto neighbors' properties, or community sidewalks and streets. The base must be fully filled when the portable hoop is in use. Portable hoops and other temporary play equipment should be stored out of sight of the street, and during extreme weather events. Only one portable basketball hoop is permitted per lot.

- A. No items that are not part of the basketball hoop may be used to keep the hoop upright (sandbags, blocks, etc.), except for Hoop Secure or similar. Please check with the ARC for further clarifications on exceptions.
- B. The owner is responsible to ensure the basketball hoop is always aesthetically pleasing. Should the hoop be in disrepair, knocked over, broken, or have any unsightly condition the District may require immediate removal.
- C. The basketball post must either be black in color or match the color scheme of the home.
- D. Backboard must be clear in color.

BACKYARD OR IN-GROUND HOOPS (not permitted for condos or multi-family products)

ARC Approval is required prior to installation. All requests will be evaluated on placement and circumstances of each backyard, as well as court area surface, visual screening, and proximity to neighbors.

- A. The owner is responsible to ensure the basketball hoop is always aesthetically pleasing. Should the hoop be in disrepair, knocked over, broken, or have any unsightly condition the District may require immediate removal.
- B. The basketball post must either be black in color or match the color scheme of the home.
- C. Backboard must be clear in color.

All other play equipment (ie. play structures trampolines, etc.) must be submitted to the ARC for approval.

BLOCKAGE OF EXISTING SOLAR PANELS

No homeowner can erect an object or construct an improvement that will obstruct access to sunlight for existing solar panels within the community without the written permission from the owner of the property with the solar panels. A copy of this written permission from the owner of the property with the solar panels must accompany the Architectural Review Submittal for approval.

CARPORTS

Carports are not permitted in the community.

CHIMINEAS/FIRE PITS/OUTDOOR FIREPLACES (not permitted for condos or multi-family products)

ARC Approval is required for all permanent installations. Gas-fired pits are recommended, and applicable governmental permits must be obtained prior to installation. In all cases these items shall not create an unreasonable amount of smoke. All applicable governmental fire/smoke bans shall be adhered to.



CLOTHES LINES

Retractable clotheslines are permitted. They shall be located on the rear of the home and shall remain retracted unless in use. Retractable clotheslines may not be mounted or attached to lot fencing or balcony.

COMPOST

Compost containers must not be immediately visible to adjacent properties and odor must be controlled. Underground composting is not permitted.

COOLING OR HEATING APPARATUS

Per Declaration, Article 3.5.3, no types of refrigerating, cooling, or heating apparatus shall be permitted on a roof or hung on exterior walls or outside of windows, except for residential solar systems. Window units are not permitted in the community. Conventional air conditioning units located on the ground of a Lot are permissible when approved by the ARC.

DECK/BALCONY/PORCH

ARC approval is necessary on all deck, balcony or porch additions and enclosures or permanent overhangs on an existing deck/balcony/porch. Deck, balcony, or porches must be constructed entirely within allowable building envelopes as established by the City and complement the colors and materials of the home. Decks cannot be higher than ten feet (10') above grade, and the support posts for elevated decks on walkout lots must have a minimum size of 6x6 and be integrated with the architecture and structure of the home.

DECK/BALCONY/PATIO - RAILINGS

To prevent access through the railings on your deck, balcony, or patio, you may install a two inch by two inch (2" x 2") or two inch by four inch (2" x 4") welded wire mesh attached to the inside of the front, back or side railings without prior ARC approval. All other materials must be approved by the ARC.

DOG RUN/DOGHOUSE

Per the Declaration, Article 3.5.2, Dog runs must be made of the same material as the approved fencing and must be approved by the ARC. No dog runs shall be visible from a street or from the ground level of any lot. One pet enclosure is allowed for each lot and cannot exceed one hundred (100) square feet. All dog runs must be located in the rear or side yard. Dog runs shall not be located within five feet (5') from any property line and shall be screened by approved materials and landscaping so that the dog run/doghouse therein is screened from neighboring lots and/or common areas. Dog houses must be painted to match the exterior of the house body and trim colors. Dog runs/dog houses therein shall be screened from neighboring lots and/or common areas. Dog Runs/Dog Houses must always be maintained to include timely cleanup/removal of dog waste and elimination of odors.

DOORS

Replacement of an existing door with the same previously approved door does not require ARC approval. Replacement of an existing door with a new type of door or color requires ARC approval. No prior ARC approval is needed for an all season, storm door or security door, if it matches the trim of the individual home.

DRIVEWAYS

Approval is required for any changes or alterations to the existing driveway. Any proposed driveway expansions shall not be permitted to promote the parking or storage of any vehicle in the front or side yard area. Must not violate municipal code/building code.

ENERGY DEVICES

- A. Solar Panels - Please see guidelines for SOLAR PV SYSTEMS. Non-glare or non-reflective finishes are preferred. The owner shall be responsible for deterring animals from nesting in, around or under roof mounted panels.
- B. Electric Automobile Charges - Must be located within the house or garage. except for those owned and maintained by the Metro District or a sub-association.
- C. Generators - Approval is required for all types of stand-by power generators. Screening may be required. Generators may not emit noise greater than eighty (80) dB to be permitted.
- D. Wind Generators are not permitted, per the Declaration, Article 3.6.3. Wind generators are allowed and shall be subject to reasonable restrictions in accordance with State Statute.

EXTERIOR LIGHTS

Per the Declaration, Article 3.10, any exterior lighting installed or maintained on the lots shall either be indirect or of such controlled focus and intensity so as not to disturb the residents of adjacent or nearby property. No light shall be emitted from any lot that is unreasonably bright or causes unreasonable glare.

Change in exterior light fixtures does not require ARC approval if fixtures meet the rules and regulations above. An addition of a light post or change in previously approved light post in the front yard or in public view does require approval of the ARC. Universal decorative lighting, such as permanent LED holiday lighting, must be approved by the ARC. Reasonable restrictions may be placed by the ARC on the hours in use, brightness and color themes.

EXTERIOR OF THE HOME

The exterior of the home is to include but is not limited to the roofs, siding, brick, stucco, color, windows and window frames, doors, light fixtures are architectural components of the neighborhood that create a unifying element. Accordingly, no homeowner may alter or change the originally installed materials, location, or color without the written consent of the ARC. No prior approval is necessary to repaint the exterior of existing home using the most recently approved color scheme or to rebuild or restore any damaged structures in a manner consistent with the plans and specifications most recently approved for such structures. Generally, no approval is required for work done to the interior of a home; however, modifications to the interior of porches, patios, and any other portions of a structure visible from outside of the structure do require prior written approval from the ARC.

FACADE EXTERIOR (STONE, BRICK, STUCCO SIDING, ETC.)

Replacement of an existing facade with the same previously approved material does not require ARC approval. Replacement of an existing facade with a new facade material requires ARC approval.

FENCES

Type and location require ARC approval. See Fence Standards (page 48) for specific fence requirements.

GATES

All gates must be approved by the ARC and match the architectural and materials outlined in fence



standards with a maximum opening of thirty-nine inches (39”), the gate width shall be thirty-six inches (36”) and may use four by six inch (4” x 6”) cedar posts with black, self-closing hardware.

GAZEBOS (not permitted for townhomes, condos, or multi-family products)

A gazebo is a detached, permanently mounted, decorative structure that is used as a seasonal gathering place. Gazebos must be approved by the ARC and need to adhere to the following guidelines:

- > Shall match the colors and materials used on the home.
- > Must be constructed entirely within allowable building setbacks as established by the City.
- > Cannot expand beyond two percent (2%) of the total square footage of the lot.
- > Cannot exceed ten feet (10’) in height

GREENHOUSES (not permitted for condo or multi-family products)

Installation of a greenhouse requires ARC approval.

HOT TUBS (not permitted for condos or multi-family products)

No hot tub shall be erected on any property without prior approval from the ARC. Hot tubs must be an integral part of the deck or patio area and are only permitted in the back yard of a home. Hot tubs must be setback at least five feet (5’) from all the property lines.

They must be screened from public view and the location shall not create an unreasonable level of noise for the adjacent property owners. In some instances, additional plant materials shall be required around the hot tub area for screening purposes.

PAINTING (EXTERIOR)

No homeowner may alter or change the original color or most recently approved color scheme without the written consent of the ARC. No prior approval is necessary to repaint the exterior of existing homes using the most recently approved color scheme. The ARC will apply the monotony rule of no home within two homes on either side or across the street can have the same color scheme. Exterior paint color schemes shall conform to the overall character of the neighborhood.

PATIOS

A patio is an exterior, at grade surface for gathering. Typical materials include concrete, gravel, paver stones or bricks. Enclosed patios are considered an addition/expansion and are covered in another section. All patios need to be approved by the ARC and located on the owner’s lot. Patios that are located within five feet (5’) of the property lines shall be screened with plant materials for privacy purposes.

PAVING/PATHS/WALKWAYS

ARC approval is required for all walks, pathways, or other purposes and for all materials used, including concrete, brick, flagstone, steppingstones, or pavers. All paving, paths and walkways shall stay within the homeowner’s property lines.

PET DOORS

Pet doors are only permitted to be installed at a ground level, and in an area that opens to an enclosed fenced area in the back yard. Pet Doors are prohibited in the front of the individual home or above ground level.

PLAYGROUND STRUCTURES/SPORT COURTS

No playground structure or equipment shall be erected on any property without prior approval from the ARC. When proposing the play equipment location, consideration shall be given to adjacent properties so as not to create an undue disturbance. Play structures, swing sets and trampolines shall be placed a minimum of 5-feet (5') from all of the property lines in the rear yard. The play equipment height shall not exceed twelve feet (12') and play structures/equipment may be required to be screened with plant materials.

Sport courts may only be located in the rear yard. Sport court surfacing materials shall be Industry Standard Material. No bright or intense court colors are permitted. Sport courts shall be located and used in accordance to not create an unreasonable level of noise. All sport courts must be setback at least 5-feet from all the property lines. Owners may be required to install additional plant materials to screen sport courts from adjacent Lots. Temporary netting shall be reviewed on a case-by-case basis but if approved, it must be stored seasonally and kept well maintained.

PLAYHOUSES (not permitted for condo or multi-family products)

Committee approval is required. Equipment shall be located in the rear or side yard. Size of playhouses will be considered on a case-by-case basis depending on parcel size and proximity to neighbors. The maximum height of the equipment should not exceed ten feet (10'). In some cases, written consent from adjacent neighbors may be required.

POOLS

Permanent pools are permitted in the back yard of the home and must be approved by the ARC and the City prior to installation. Temporary and above ground pools, beside kiddie pools, are permitted during Spring and Summer seasons and shall be stored through Fall and Winter seasons.

RAIN BARRELS (not permitted for condo or multi-family products)

Rain barrels shall be located in the rear yard. The barrel material shall compliment the exterior of the house. The rain barrel shall not hinder the established drainage pattern and water flow of the lot.

ROOFING MATERIAL

Roofing materials refer to the shingles or tile material installed on a building rooftop. Replacement of an existing roof with the same previously approved material does not require ARC approval. Replacement of an existing roof with new roofing material or roof pattern or roof color requires ARC approval. All replacement roof shall coordinate with the exterior color and materials on the house.

SHEDS AND OUTBUILDINGS

ARC approval is required. Sheds and outbuildings shall be allowed only in rear yards. Sheds and outbuildings must be the same material and color as the exterior of the home, unless otherwise approved by the ARC. Sheds and outbuildings shall not be more than ten feet (10') high at the peak, nor larger than one hundred-twenty (120) square feet. Siding, roofing, and trim material must match those on the home. The ARC, in reviewing the application for shed and outbuilding approval, shall consider parcel grading, fence locations, landscape screenings, etc. in granting any approvals for a shed.

SKYLIGHTS (not permitted for condos or multi-family products)

Approval is required. Small solar tube skylights are permitted but large bubble-type skylights are not allowed.



SOLAR PV SYSTEMS

Solar Photovoltaic (PV) Systems are used to absorb sunlight for electricity, or heat, as a component of a building's or home's overall energy system and a method of conserving energy. Homeowners are encouraged to incorporate energy conservation into their building/home systems, but any Solar PV System must be specifically approved by the ARC prior to installation and meet the guidelines below.

- > All Solar PV Systems must be designed and installed by a professional licensed contractor. The Architectural Review Submittal needs to be accompanied by a plan that is "to scale" from the licensed contractor who will be installing the system with material and/or manufacture's description of system, photos/pictures of system and color of system.
- > Mounting: A Solar PV System array can either be "flush mounted" or "tilt mounted". However, in order to integrate the Solar PV System into the architecture of the home, the Solar PV Systems array must be flush mounted, that is, to match the existing plane of the roof (parallel to roof line), unless on a flat roof. If installed on a flat roof, the array may be tilted to allow proper exposure to the sun provided that a letter is provided to the Architectural Review Committee from the solar professional involved explaining the need for a tilt mounted array.
- > Colors: Any component of the Solar PV System must integrate into the architecture of the home. The color of the Solar PV System components should generally conform to the color of the roof shingles to the extent practical (for instance, black frames on dark colored shingles, silver frames on light colored shingles). Solar "shingles" which mimic the look of a composite shingle are acceptable but must match the color of the current roof shingles without prior ARC approval.
- > Balance of Systems: Inverters and DC safety disconnects are typically mounted in the basement, garage, or near the electrical meter on the outside of a home. The safety disconnects are usually required by the local utility to be mounted next to the electrical meter. The Owner is required to obtain any City permits and electrical inspections required in connection with the Solar PV System. Conduit should be installed near a drainpipe or other existing runs from the roof to hide the conduit as much as possible. In the event that compliance to these guidelines causes financial burden, then the homeowner seeking approval for a variance due to financial burden shall provide a minimum of two bids depicting the cost of installation of the solar systems in compliance with this policy and one depicting the desired alternative method. Variances may be granted if compliance with these guidelines would significantly increase the purchase price or operating cost of the Solar PV System or significantly decrease its performance or efficiency.

TRASH BIN ENCLOSURES

Trash bin enclosures require approval and will be reviewed on a case-by-case basis. Trash bins must abut the side of the home, be located behind the wing fence or ten feet (10') from the front facade of the home and be screened from view. The enclosures can be no taller than six inches (6") higher than the trash receptacles and must be made of three (3) sides including a gate which prohibits visibility of the containers and include with a cover with matching roof material. The structure must be maintained or, if not maintained, removed. The trash bins shall not be visible from the front yard or street.

VEGETABLE GARDENS

Vegetable gardens do not require approval if they are located in the rear or side yard. All gardens (in ground and raised boxes) shall be setback at least five feet (5') from all property lines. All gardens must be kept weed free and well maintained. Landscape timbers, bricks or decorative concrete blocks are encouraged materials for raised garden beds. Small vegetable gardens in pots or other reasonably sized containers are permitted on balconies or porches in condos and multi-family products, but are subject to any subsequent rules and regulations adopted by the condo or multifamily association.

WALLS (STONE, BRICK, STUCCO, WOOD, RETAINING, ETC.)

Walls that were not part of the original vision and plan of the community can negatively affect the original grading and drainage and the overall aesthetic within the community. Accordingly, no owner shall alter, add, or change the walls throughout the community or in their individual yards without prior ARC approval. All proposed retaining walls shall be constructed with materials that coordinate with the exterior of the house and shall not alter the established drainage pattern of the lot.

WATER FEATURE (PONDS, FOUNTAINS, ETC.)

It is important that all water features do not negatively affect the physical aesthetics, improvement or adversely affect grading or drainage. Water features are permitted but must adhere to the following guidelines and be approved by the ARC:

- > Water features must use recycled water.
- > Height – Cannot be higher than four feet (4') including any spouting water.
- > Width – water features cannot expand beyond fifteen percent (15%) of the total square footage of the front or rear yard area.
- > Should drought or water restrictions be enforced by the City the Owner will need to follow all such restrictions regarding the running of their water feature.
- > Underground water features will not exceed five feet (5') in depth.
- > All water features need to follow the established landscape Design guidelines, including all grading and drainage requirements.
- > All water features must be located at a minimum of five feet (5') from the foundation of the existing residence and five feet (5') from property lines.

WINDOWS

Replacement of a window or window frame with the same previously approved material does not require ARC approval. Replacement of a window with a new window, window frame or location requires ARC approval.

YARD DECORATIONS, ORNAMENTS, SCULPTURES ETC.

All yard decorations, ornaments, sculptures, bird house and baths must be approved by the ARC. Yard ornaments that do not exceed five feet (5') in height and are not more than two feet (2') in width like bird houses or garden decorative stakes that are placed in the back yard may be acceptable. Excessive yard decoration may be reviewable by the ARC.



This page intentionally left blank.

3.3 ARCHITECTURAL REVIEW COMMITTEE PROCEDURES

- i. Per the Declaration, the Board of Directors may establish in its discretion from time to time an ARC for the District. In the absence of appointment of an ARC the Board will act as the ARC. The ARC shall consist of three (3) persons appointed by the Board of Directors and if the Board elects not to appoint an ARC then the Board will act as the ARC until at which time an ARC is appointed by the Board, which persons may be directors; provided, however, that until all of the Lots That May Be Included have been conveyed to the first Owner thereof (other than Declarant or a Builder), Declarant may appoint the ARC in which case the ARC shall consist of at least one but not more than three persons as determined by the Declarant. The power to “appoint,” as provided herein, shall include without limitation the power to: constitute the initial membership of the ARC; appoint member(s) to the ARC on the occurrence of any vacancy therein, for whatever reason; and remove any member of the ARC, with or without cause, at any time, and appoint the successor thereof. Each such appointment may be made for such term(s) of office, subject to the aforesaid power of removal, as may be set from time to time in the discretion of the appointer.
- ii. The ARC will serve a term of two (2) years each, except the initial ARC which will serve the terms of one (1) member year and two (2) member years.
- iii. The ARC shall appoint a chairperson.
- iv. The Board shall appoint one Board Member to join the ARC. The ARC may coordinate via email, in-person meetings or other practical means of communication to determine the approval, denial or conditions associated with approval/denial. A majority vote of the ARC will constitute an approval or denial and include any associated conditions thereon.
- v. The ARC where practical should maintain emails or other written communication involving approval, denial or associated conditions when practical. The homeowner shall receive in writing or by electronic means communication outlining the ARC’s approval, denial that includes any and all conditions associated therewith.
- vi. Per the Declaration, a majority vote of the ARC is required to approve a request for approval, unless the ARC has appointed a representative to act for it, in which case the decision of such representative shall control. If a representative acting on behalf of the ARC approves or denies a request for Architectural approval, any Owner shall have the right to an appeal of such decision to the full ARC, upon a request therefore submitted to the ARC within thirty (30) days after such approval or denial by the ARC’s representative. Unless the Board of Directors is acting as the ARC, if the ARC approves or denies a request for Architectural approval (whether by original decision or an appeal) then, any Owner shall have the right to an appeal of such decision to the Board of Directors, upon a written request therefore submitted to the Board of Directors within thirty (30) days after such decision by the ARC.



- vii. The ARC shall have the right to disapprove any application which is not suitable or desired for aesthetic or other reasons.
- viii. Records: Per the Declaration, ARC shall maintain written records of all applications submitted to it and all actions taken by it thereon and such records shall be available for inspection in accordance with the District's governance policies.
- ix. Liability: Per the Declaration, neither the Board of Directors, nor the ARC, nor any members thereof, nor any representative of the ARC appointed to act on its behalf, shall be liable in damages to any Person, or to any Owner, by reason of any action, failure to act, approval, disapproval or failure to approve or disapprove in regard to any matter within its jurisdiction hereunder.
- x. Variance: Per the Declaration, the ARC may grant reasonable variances or adjustments from any conditions and restrictions imposed by the Declaration, Rules and Regulations or Guidelines in order to overcome practical difficulties or prevent unnecessary hardships arising by reason of the application of any such conditions and restrictions. Such variances or adjustments shall be granted only in case the granting thereof shall not be materially detrimental or injurious to the other property or Improvements in the Community and shall not militate against the general intent and purpose hereof.
- xi. Waivers; No Precedent: Per the Declaration, the approval or consent of the ARC or any representative thereof, to any application for Architectural approval shall not be deemed to constitute a waiver of any right to withhold or deny approval or consent by the ARC or any representative thereof as to any application or other matters whatsoever as to which approval or consent may subsequently or additionally be required. Nor shall any such approval or consent be deemed to constitute a precedent as to any other matter.
- xii. Inspections: The ARC may make periodic inspections of the Homes to ensure compliance with these Design guidelines and any existing ARC approvals. If entry upon private property is required for any reason the ARC shall provide seventy-two (72) hour notice.
- xiii. Amendments: The Guidelines may be amended by the Board of Directors or the ARC with Board approval. Amendments to the Guidelines shall apply prospectively only. They shall not require modifications to or removal of any structures previously approved once the approved construction or modification has begun. However, any new work on such structures must comply with the Guidelines as amended. There shall be no limitation on the scope of amendments to the Guidelines, and such amendments may increase requirements previously imposed or make the Guidelines less restrictive.

4.0 LANDSCAPE STANDARDS:

4.1 PUBLIC / OPEN SPACE LANDSCAPE

The Mulberry Metro District will be in charge of all public open spaces, sidewalks, and community trails. The District will maintain irrigation lines for common areas, be responsible for snow removal on trails in the defined common area, pool and maintenance thereof, common trash receptacle removal, insurance for the aforementioned items (unless City-maintained), maintenance of the fences constructed in the common area, as well as maintenance of monumentation signage. Where applicable, sub associations (eg. condo) or HOA's may be created to manage issues specific to smaller subareas of the community. The City of Fort Collins will own and maintain the regional trail parallel to the railroad. The City will also own and maintain the landscape in the Greenfields and SH 14 frontage road roundabout and the associated islands around the roundabout.

The public and open space landscaping at Bloom will be comprised of six distinct zones. Zones are generally described as follows:

1. Greenfields Gateway - The intersection of Greensfields Drive and Mulberry Street is the southern gateway to Bloom and a highly visible entrance into Fort Collins.
2. Community Green - The Community Green is located in Bloom's mixed-use commercial zone and is the southern anchor of the Aria corridor.
3. Lower Aria - The southern section of Aria Parkway is where Bloom's urban core starts to transition into the more suburban portions of the neighborhood.
4. Upper Aria - The upper section of Aria Parkway transports people to Bloom Park to the north while acting as a transition to the urban core to the south.
5. Bloom Park - As the northern anchor to the Aria corridor, the neighborhood park and pool will be the center of activity for recreation and leisure.
6. Cooper Connection - Running west to east, this connector transports people and pollinators from the neighborhood park to the Cooper Slough trail system.



ZONE MAP



Note: Image is conceptual and shown for illustrative purposes only. Land Use Plan is subject to change

Zone 1 - Greensfields Gateway

Zone 2 - Community Green

Zone 3 - Lower Aria

Zone 4 - Upper Aria

Zone 5 - Bloom Park

Zone 6 - Cooper Connection.

4.2 PRIVATE LANDSCAPES

1. The location of trees and shrubs must be carefully planned so that mature sizes do not interfere with fences, landscaping, or structures on adjacent lots.
2. Front yard landscaping should create a cohesive “flowing” relationship between adjacent lots.
3. Front yard and side yard landscaping along all streets shall extend to the back of curb at street, including within the street Right of Way behind curb line.
4. Trees, shrubs, and planting beds should blend together between adjacent lots for a pleasing streetscape.
5. Planting beds between adjacent lots should appear unified by using the same type of rock or wood mulch.
6. Avoid designs with formal plantings, hard edges, mow curbs, or other materials that delineate lot lines.
7. Landscaping adjacent to native open spaces should blend and harmonize with the natural landscape.
8. Retaining walls should be low, visually attractive, and made of natural materials to complement the architectural style of the home. They should generally blend with the masonry used on the home and should appear to be a “natural outcropping”.
9. Garages, parking areas, driveways, utility boxes, trash enclosures, pet enclosures, play equipment, gardens, pools, tennis courts, hot tubs, etc., shall be screened from adjoining residences and streets.
10. Final tree placement is subject to required setbacks from utilities, light poles, and signs. Refer to Final Plat Landscape Plan for homebuilder approximate tree lawn tree placement location.

4.2.1 FRONT YARD LANDSCAPE REQUIREMENTS

1. All front yard landscaping shall be completely landscaped with planting beds and drought tolerant bluegrass turf or approved equal. Water conservation is encouraged by utilizing grasses that require significantly less water or considering a xeriscape design. Xeriscape meaning installing a smaller turf area, native grasses in lieu of turf and/or alternatives (e.g. clover) with ARC approval, utilizing low-water plants, using soil amendments and mulches, and irrigating efficiently. In approved situations, zero-scaping practices may also be implemented on a case-by-case basis, and as reviewed by the ARC. Zero-scaping meaning installing only non-living materials in the landscape.
2. Landscape plans are encouraged to be designed by a professional landscape designer/architect.
3. All front yard landscaping (as applicable) must be completed within one hundred-eighty (180) days of the date of closing if the closing occurs during the growing season (April 1-September 1 of the same year) or during the next growing season if the closing occurs outside of this cycle. The tree lawn must be installed within one hundred-eighty (180) days of closing.
4. Buried sprinkler systems must be installed in front, side, and backyards. All plant material shall be irrigated.
5. Trees shall be minimum 2” caliper and shrubs shall be minimum five (5) gallon.
6. Turf shall be a high quality drought tolerant bluegrass or an approved drought tolerant fescue.
7. Additional lot configurations and home types are permitted in the Mulberry and Greenfields PUD Master Plan beyond those whose landscape standards are shown below. Should additional housing product be proposed that is not addressed by the below standards, landscape standards will be determined by the ARC and shall have a character consistent with the standards within this document.



4.2.2 REAR/SIDE YARD LANDSCAPE GUIDELINES

COMPLETION DATES

All rear and side yard landscaping (as applicable) must be completed within one hundred-eighty (180) days of the date of closing if the closing occurs during the growing season (April 1-September 1 in the same year) or during the next growing season if the closing occurs outside of this cycle. The tree lawn must be installed within one hundred-eighty (180) days of closing.

DRAINAGE/GRADING

Per the Declaration, Article 3.14, each Owner shall maintain the grading upon the Owner's Lot, at the slope and pitch fixed by the final grading thereof, including landscaping and maintenance of the slopes. The District is entitled to take necessary actions to ensure proper drainage from the Lots and Common Elements. Each Owner and the District agree, for themselves and their successors and assigns, that they will not in any way interfere with the established drainage pattern over any real property which they have a duty to maintain, from adjoining or other real property. In the event that it is necessary or desirable to change the established drainage over any Lot or Common Elements which an Owner or the District has a duty to maintain, then the party responsible for the maintenance of such real property shall submit a plan to the Board for their review and approval. For purposes of this Section, "established drainage" is defined as the drainage that exists at the time final grading of a Lot is completed.

No Owner may install improvements or alter grading to adversely affect drainage on any Lot. No Owner may alter, obstruct, or obliterate any drainage swales, pans, easements, or channels located or installed on any Lot or Common Areas. Each Single Family owner shall maintain all gutters, downspouts and extensions within such Owner's Lot to ensure that the gutters and downspouts remain in the down position and are free and clear of all obstructions and debris and that the water flow from such gutters and downspouts is directed away from the foundation and/or slabs on any improvement.

LANDSCAPE MAINTENANCE

To maintain the environmental ethic of the Community, the following performance standards shall be followed by Owners with respect to maintenance of their residential landscaping:

1. Over-spray or excess runoff of irrigation water shall be avoided.
2. Watering Hours- The District may adopt water schedules and/or drought mitigation restrictions.
3. All landscapes shall be maintained to eliminate noxious weeds and hazards. Turf grass should generally be mowed to maintain a uniform appearance.

LOCAL STREET RIGHT-OF-WAY (AREA BETWEEN STREET AND SIDEWALK)

The local street right-of-way (area between the street and sidewalk) landscaping, including irrigation, tree lawns and street trees, shall be installed by the Homebuilder or Developer and maintained by the individual adjacent owner, Builder, or Metro District. Cottage tree lawns will be maintained by the District. The owner shall be responsible for ensuring that all tree lawns are installed in accordance with the approved Bloom master development plans. The tree lawn shall be installed with bluegrass or approved equal. Tree lawns may be xeriscaped subject to local municipal code and regulations - ARC approval is required. The landscaping within the tree lawn shall be completed within six (6) months of the issuance of the certificate of occupancy for the home abutting the tree lawn.

LANDSCAPING - FRONT YARD

The minimum planting standards for a front yard is one (1) tree, two inch (2") Caliper, and five to ten (5-10) shrubs depending on lot size (see below lot typicals for specific requirements). Cottage lots may have three to five (3-5) shrubs. All shrubs shall be located in defined planting beds.

*Ornamental grasses and perennials may be substituted for shrubs at a rate of three (3) grasses/perennials per one(1) five (5) gallon shrub. Required parkway trees are considered front yard trees.

LANDSCAPING - REAR YARD

The minimum planting standards for a rear yard is five to ten (5-10) shrubs and cottage lots may have three to five (3-5) shrubs* depending on lot size. All shrubs shall be located in mulched planting beds.

*Ornamental grasses and perennials may be substituted for shrubs at a rate of three (3) grasses/perennials per one (1) five (5) gallon shrub.

LANDSCAPING - TURF

Irrigated bluegrass, or approved equal, turf (lawn areas) shall cover no more than fifty percent (50%) of the front or fifty percent (50%) of the rear yard landscape area. Approval is required prior to the installation of artificial turf. No artificial turf is allowed in front or street facing side yards. Artificial turf may not exceed fifty percent (50%) of the rear yard and will require screening so as not to be visible from the street or any common area tracts.

LANDSCAPING- ARTIFICIAL TURF

Artificial turf may be considered inside rear yards but not areas visible from public streets. Total artificial turf of any height may not exceed fifty percent (50%) of the total area of the lot that is able to be landscaped on non-cottage lots. Cottage lots may be higher and will be reviewed on a case-by-case basis unless installed by the home builder.

The design intent is for artificial turf to emulate natural grass. Please state the intended use of the turf on the application. If selecting one of the pre-approved artificial turf brands listed below, please submit the manufacturer cut sheet or informational sheet with the application. If a pre-approved artificial turf is not being proposed, the application must include a physical sample of the proposed material showing the color and pile height along with a manufacturer cut sheet or informational sheet.

If artificial turf is utilized for on-lot landscaping, pet odors must be mitigated through appropriate means including but not limited to routine spray/wash down.

ALLOWABLE PRODUCTS

The color must be similar to the geographical area, preferably a blended, multi-color monofilament fiber. There are certain products that have been pre-approved by the ARC as meeting the requirements of these Guidelines. The pre-approved brands are listed below. The homebuilder may install other artificial turf products at the time of home construction following approval by the ARC.

- > Easy Turf – Ultimate Natural Artificial Turf two inch (2”) height.
- > Easy Turf – Pedigree one and one-half inch (1 1/2”) height.
- > Next 2 Natural – Natural Envy two inch (2”) height.
- > Next 2 Natural – Sense two inch (2”) height.
- > Mile High Synthetic Turf – Colorado Blend Pro two inch (2”) height.
- > Mile High Synthetic Turf – Colorado Blend King two and three-eighths inch (2 3/8”) height.
- > Purchase Green – Arizona Platinum Olive two inch (2”) height.
- > Purchase Green – Arizona Platinum Spring two inch (2”) height.



INSTALLATION CONSIDERATIONS:

- > Professional installation is required and must include a weed barrier and a porous, aggregate road base for drainage.
- > Proper infill for residential application, such as a silica sand or “Envirofill” for kid and pet areas must be used. If only for a pet use area, a product with less secondary thatch may be used. Infill must not be toxic to humans or pets and must blend into the turf and not be visually distracting.
- > The established drainage pattern may not be blocked or altered by the installation of artificial turf.
- > A weed suppressor must be used under seams and the seams must be properly secured.
- > If an artificial turf area will meet an area where native landscaping has been established, it must be separated by a barrier of at least four inches (4”) of hardscape or planting area.

MAINTENANCE CONSIDERATIONS

Artificial turf must be cleaned as necessary and periodically groomed to maintain its appearance. The District reserves the right to inspect and require replacement after the life expectancy has been reached, typically fifteen to twenty (15 to 20) years, or if the turf is not maintained in good condition.

4.2.3 SYNTHETIC / ARTIFICIAL TURF REQUIREMENTS

Synthetic/Artificial Turf is permitted in back yards and side yards behind wing fences and privacy fences. Concrete or stone edging is required at all locations where the artificial turf is terminated. Synthetic/ Artificial Turf is not permitted in front yards or yards adjacent to Open Space. Design Review approval is required.

1. The artificial grass product must be made of Polyethylene and have a minimum face weight of fifty (50) ounce with a permanent backing.
2. The color must be similar to the geographical area, preferably a blended, multi-color monofilament fiber with that and a minimum pile height of one and one-half inches (1.5”).
3. Professional installation is required and must include a weed barrier and a properly prepared aggregate base for drainage. An infill system is required.
4. Artificial grass must be cleaned as necessary and periodically groomed to maintain its appearance.
5. Artificial grass products to ensure the aesthetic properties are maintained. The Board of Directors reserves the right to require replacement after the expectancy has been reached, typically twenty (20) years.

The following must be submitted with the Application for Architectural Improvement

1. A sample of the product including model name and style
2. Complete product specification sheet from the manufacturer
3. The manufacturer’s warranty on the product being submitted
4. Photo(s) of the area to be covered by the artificial grass
5. Photo(s) of proximity areas as well as description of the method of installation.

LANDSCAPING - XERIC

All xeric landscape plans must incorporate the installation of an automatic underground irrigation system to help maintain the plantings. Xeric landscape plans, for front or rear yards, that do not propose irrigated turf grass as a ground cover will be required to have living plants (shrubs, ornamental grasses or perennials) cover fifty percent (50%) of the front or rear yard landscape area upon the plants installation and seventy-five percent (75%) coverage of the landscape area after three years growth. The use of a variety of mulch types and evergreen plants are required to add year-round interest and color.

NOXIOUS PLANTS

The following is a list of plants considered to be invasive species and not to be planted in Bloom.

Perennials

- > Bouncing bet, soapwort Cypress spurge
- > Dalmatian toadflax, butter & eggs Dame's rocket
- > Mediterranean sage
- > Myrtle spurge, Mercer's spurge Ox-eye daisy
- > Perennial sweet pea, perennial pea vine Purple loosestrife
- > Scentless chamomile Sulfur cinquefoil
- > Sweet clover, white & yellow

Grasses

- > Crested wheatgrass, Orchard grass, Smooth brome
- > Hungarian brome grass, Timothy

Shrubs

- > Buckhorn
- > Scotch Broom

ROCK

Areas of gravel or river rock shall be restricted to the brown, gray, or Colorado sandstone color tones. Rock color ranges with natural looking stone that fits within the overall character of the community are permitted and encouraged.

4.2.4 XERISCAPE REQUIREMENTS

All Xeriscape design elements must follow the Seven Principles of Xeriscape required by The City of Fort Collins (fcgov.com/xeriscape).

1. Plan Ahead:

- > Create a scaled drawing of the lot, including buildings and walks. Identify sunny and shady areas, slopes and views.



- > Evaluate the needs of people using the landscape. Do kids and pets need a big open area? Is a large deck for entertaining important?
- > Group plants with similar water needs to make watering easier.
- > Phase in the landscape plan as money and time allow.

2. Improve the Soil:

- > Good soil absorbs and retains water better than poor soil.
- > Send a soil sample to a soil lab to determine nutrient content.
- > Most Colorado soils benefit from adding two to three cubic yards of organic matter, such as commercial compost or aged manure, for every one-thousand (1,000) square feet of landscape area.

3. Irrigate Efficiently

- > Grass: use low-volume, low-angle sprinklers.
- > Trees, shrubs, flowers and ground covers: use drip, spray or bubbler emitters.
- > Adjust your watering times monthly to meet seasonal needs.
- > Install a rain shutoff device.
- > Efficient hose-end sprinklers throw large drops of water, not a mist, close to the ground.
- > Water deeply and infrequently to develop deep roots.
- > Water between 9 p.m. and 8 a.m. to reduce water loss due to evaporation.

4. Limit Turf Areas

- > Confine the lawn to high traffic areas and areas where it will be used.
- > Kentucky bluegrass requires twenty-four to twenty-six inches (24"-26") of supplemental irrigation in a normal precipitation year, compared to Fine Fescue which requires eighteen to twenty inches (18"-20") and Buffalograss which requires eight to ten inches (8"-10").
- > Wildflowers and native grasses are excellent lawn substitutes.
- > Shrubs, perennials and ground covers use less water and provide a cool, green appearance.
- > Place mulch around driveways or as paths.
- > Expand outdoor-living areas by installing decks, patios and walkways.

5. Select Appropriate Plants

- > Zone together plants with similar water and sunlight needs.
- > Nurseries carry trees, shrubs, perennials and groundcovers that are low water-using.
- > Install a variety of plants with different heights, colors and textures.
- > Choose plants for their seasonal interest, including fall color and/or interesting berries, bark or seed heads.

6. Use Mulch

- > Cover planting areas with two to four inches (2"-4") of mulch to conserve soil moisture, control weeds and add interest to the landscape.
- > Bark chips, shredded wood chips or pole peelings decompose and improve soil texture but need to be restored from time to time.
- > Rock and gravel mulches are practical in windy spots and unplanted areas.
- > Apply mulch directly to the soil surface or over a landscape fabric.
- > Do not use black plastic; it prevents air and water from reaching plant roots.

7. Maintain It

- > Check trees and shrubs for pruning needs once a year.
- > Frequently prune flowering perennials to stimulate blooming.
- > Mow grass when it is about 1/3 higher than the desired height.
- > Leave clippings to recycle nutrients into the soil.



4.3 SIDE YARD USE EASEMENTS

Side yard use easements may occur from front property line to rear property line on the single family detached ally-loaded lots. Refer to the approved Mulberry and Greenfields PUD Master Plan for specific information.

In general, Side Yard Use Easements function as shown below:

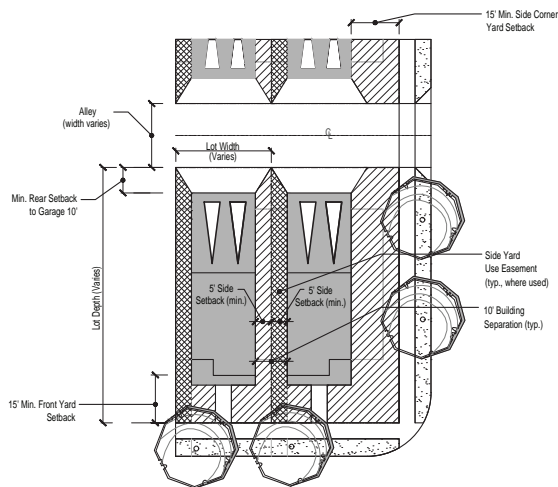

Single Family Detached Rear Load w/ Side Yard Use Easement

INSTALLATION AND MAINTENANCE REQUIREMENTS

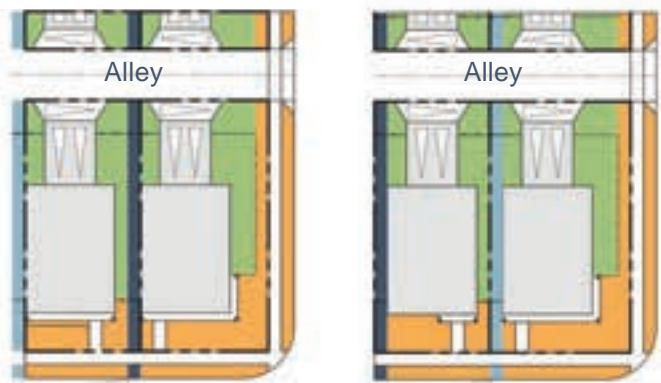

Street/Open Space Front

- Property Line
- 3-Rail Fencing
- Landscaping installed by Builder and maintained by homeowner or sub-association
- Landscaping installed by homeowner or builder and maintained by homeowner
- Side Yard Use Easement: Grantee
- Side Yard Use Easement: Grantor

4.4 LANDSCAPE LOT TYPICALS, MAINTENANCE, AND REQUIRED PLANTINGS

4.4.1 SINGLE FAMILY DETACHED FRONT & SIDE LOAD

INSTALLATION AND MAINTENANCE REQUIREMENTS

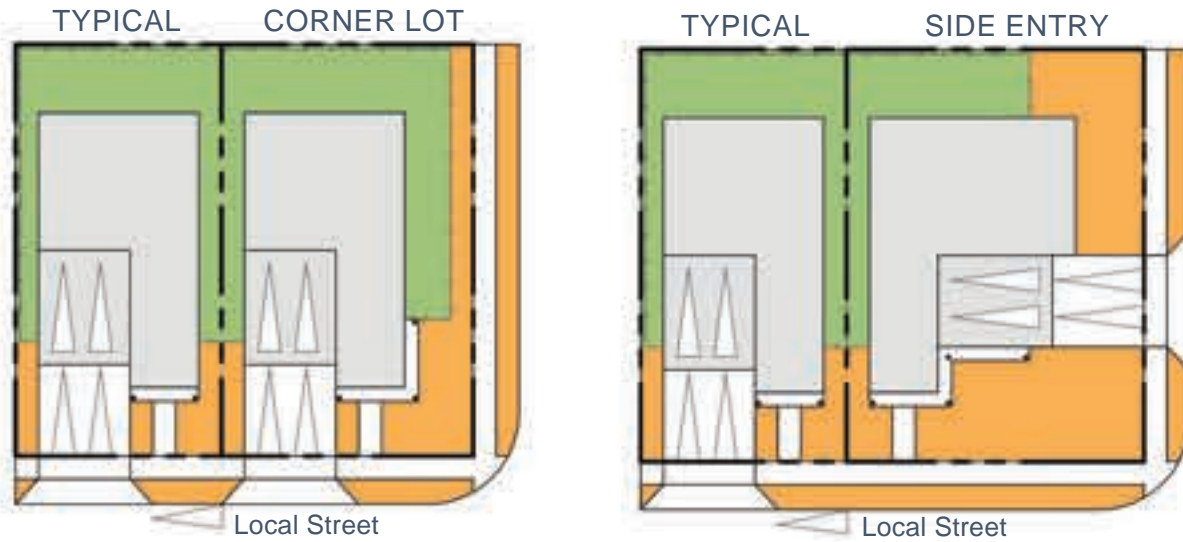

- FOR SALE**
- Property Line
 - five feet (5') horizontal privacy fence
 - Orange Landscape installed by Builder and maintained by homeowner or sub-association
 - Green Landscape installed by homeowner or builder and maintained by homeowner

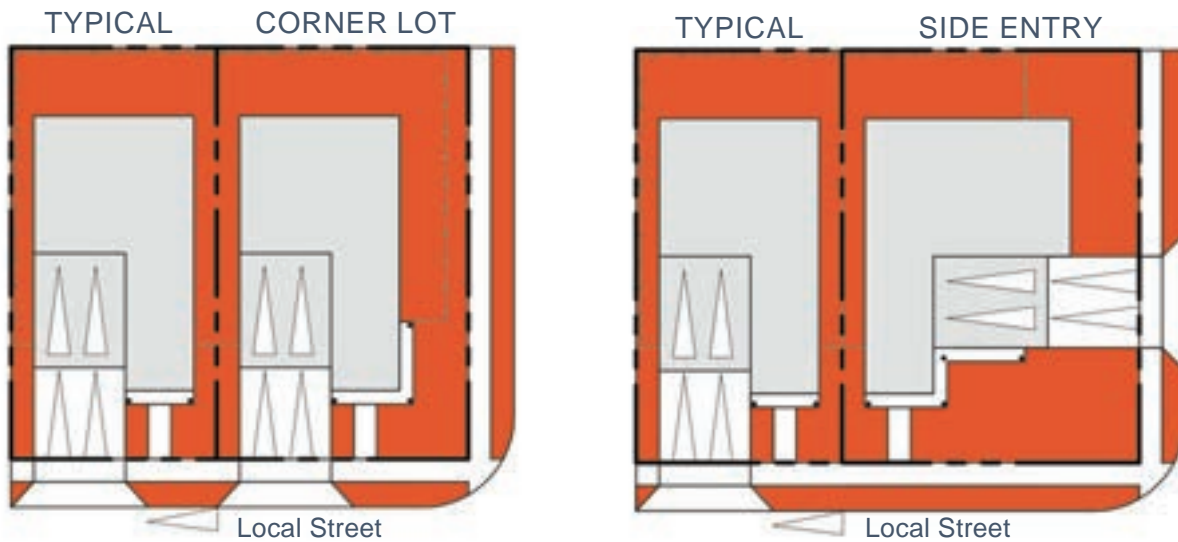

- FOR RENT**
- Property Line
 - Five feet (5') horizontal privacy fence
 - Orange Landscape installed by District or Builder and maintained by District or sub-association
- *Note: SFD for-rent may have other site plan layouts other than units facing a street and may be organized around green court



REQUIRED PLANTING AND TYPICAL LOT PLANTING DESIGN

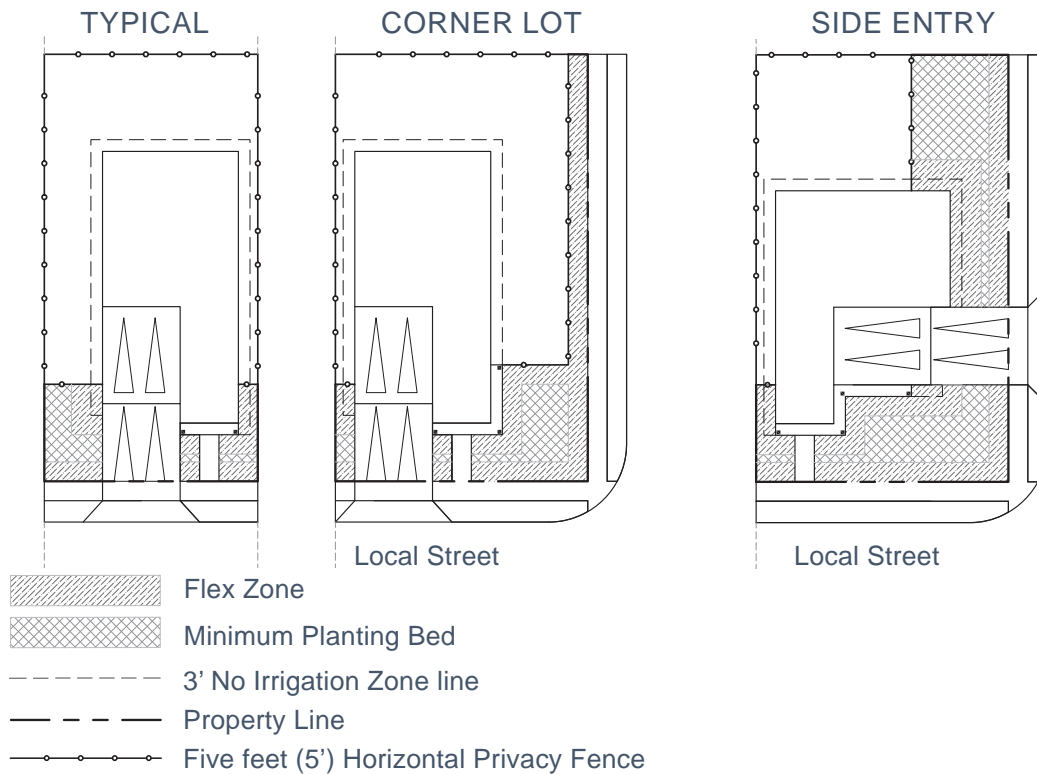

Minimum Required Quantities By Lot Type and Location					
	Typical Lot	Corner Lot		Side Entry	
Material	Front Yard	Front Yard	Side Yard	Front Yard	Side Yard
Ornamental Tree or Sm. Evergreen Tree	Parkway Trees	Parkway Trees	Parkway Trees	Parkway Trees	Parkway Trees
Evergreen Shrubs	1	1	3	1	3
Deciduous Shrubs/ Ornamental Grasses/ Perennials	5	5	5	5	5





*The Street Tree required by the City of Fort Collins meets the requirement for the Front Yard Tree. Refer to approved plans for required minimum tree sizes.

NOTES:

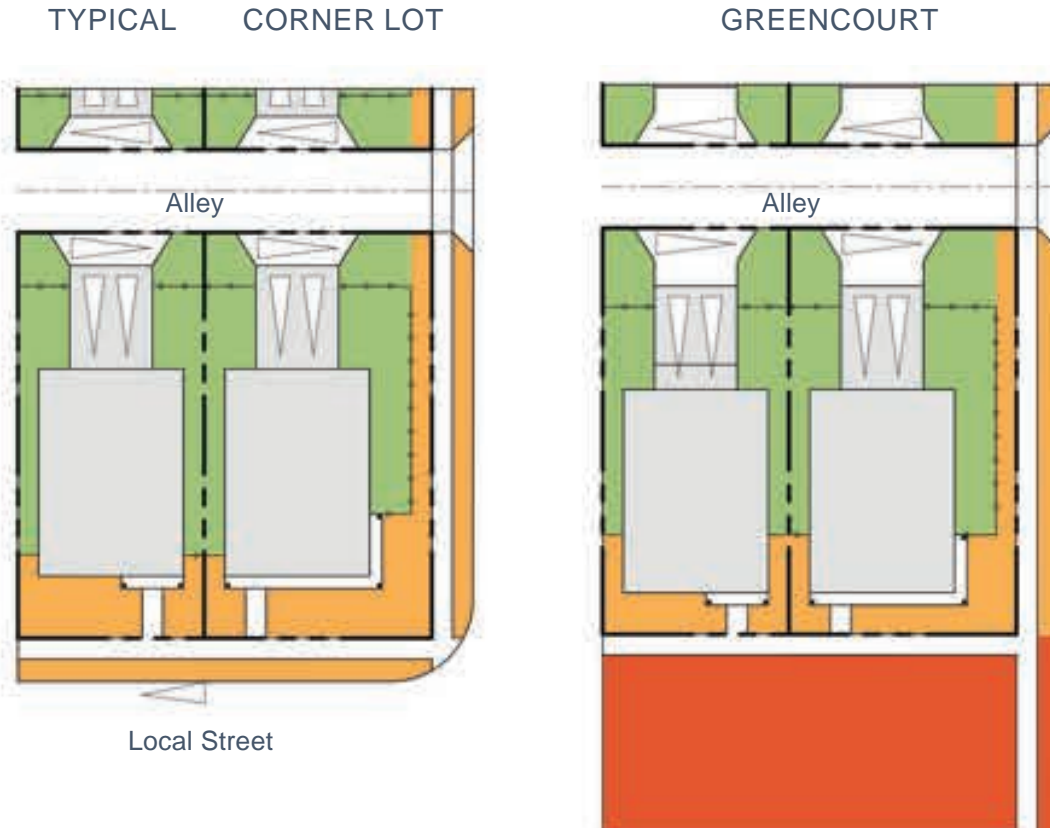
1. Turf may have undulating form, but should not be narrower than five feet (5') in any area. Turf and bed line should meet adjacent home turf and bed lines when possible.
2. Maintain three foot (3') no irrigation zone around principal structure per geotechnical recommendations. Required five foot (5') planting bed does not include three foot (3') no irrigation zone.
3. Flex zone allows homeowner to choose to expand either turf or planting bed areas.
4. Side yard incorporates area adjacent to side fencing and must meet a minimum of eighty percent (80%) coverage of live landscape material at least three feet (3') in height.
5. A diversity of plant types must be incorporated in all planting beds. No more than 25% of the same species of live shrubs, ornamental grasses, or perennials, shall be planted.
6. Variations from required planting may be approved by the Architectural Review Committee on an individual basis.

4.4.2 SINGLE FAMILY DETACHED REAR LOAD INSTALLATION AND MAINTENANCE REQUIREMENTS



-  Property Line
-  Five feet (5') Horizontal Privacy Fence
-  Landscaping installed by District or Builder and maintained by District or sub-association
-  Landscaping installed by Builder and maintained by homeowner
-  Landscaping installed by homeowner or builder and maintained by homeowner



REQUIRED PLANTING AND TYPICAL LOT PLANTING DESIGN

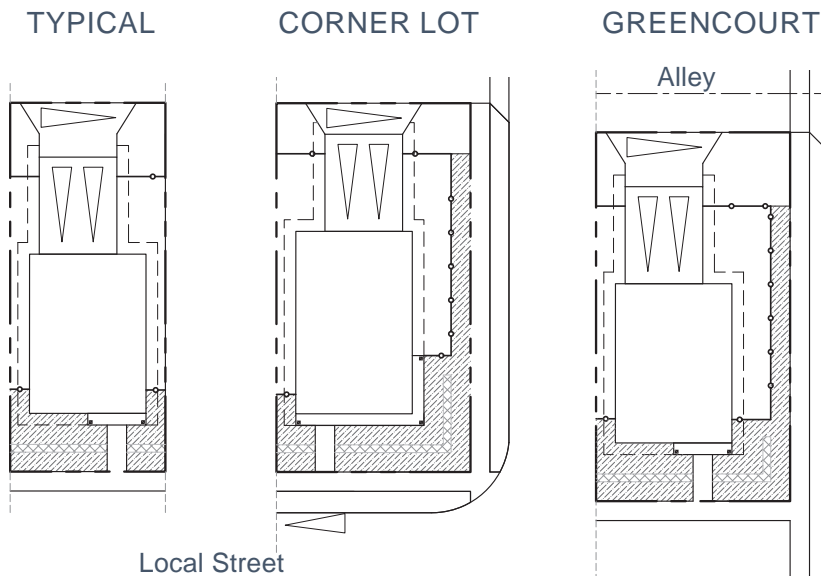

- Flex Zone
- Minimum Planting Bed
- 3' No Irrigation Zone line
- Property Line
- Five feet (5') Horizontal Privacy Fence

Minimum Required Quantities By Lot Type and Location					
Material	Typical Lot	Corner Lot		Lot Adjacent to Greencourt	
	Front Yard	Front Yard	Side Yard	Front Yard	Side Yard
Parkway Trees	0*	0*	0	1	0
Evergreen Shrubs	1	1	3	3	3
Deciduous Shrubs/ Ornamental Grasses/ Perennials	3	5	5	5	3

*The Street Tree required by the City of Fort Collins meets the requirement for the Front Yard Tree. Refer to approved plans for required minimum tree sizes.





NOTES:

1. Turf may have undulating form, but should not be narrower than five feet (5') in any area. Turf and bed line should meet adjacent home turf and bed lines when possible.
2. Maintain three foot (3') no irrigation zone around principal structure per geotechnical recommendations. Required five foot (5') planting bed does not include three foot (3') no irrigation zone.
3. Flex zone allows homeowner to choose to expand either turf or planting bed areas.
4. Side yard incorporates area adjacent to side fencing and must meet a minimum of eighty percent (80%) coverage of live landscape material at least three feet (3') in height.
5. A diversity of plant types must be incorporated in all planting beds. No more than 25% of the same species of live shrubs, ornamental grasses, or perennials, shall be planted.
6. Variations from required planting may be approved by the Architectural Review Committee on an individual basis.

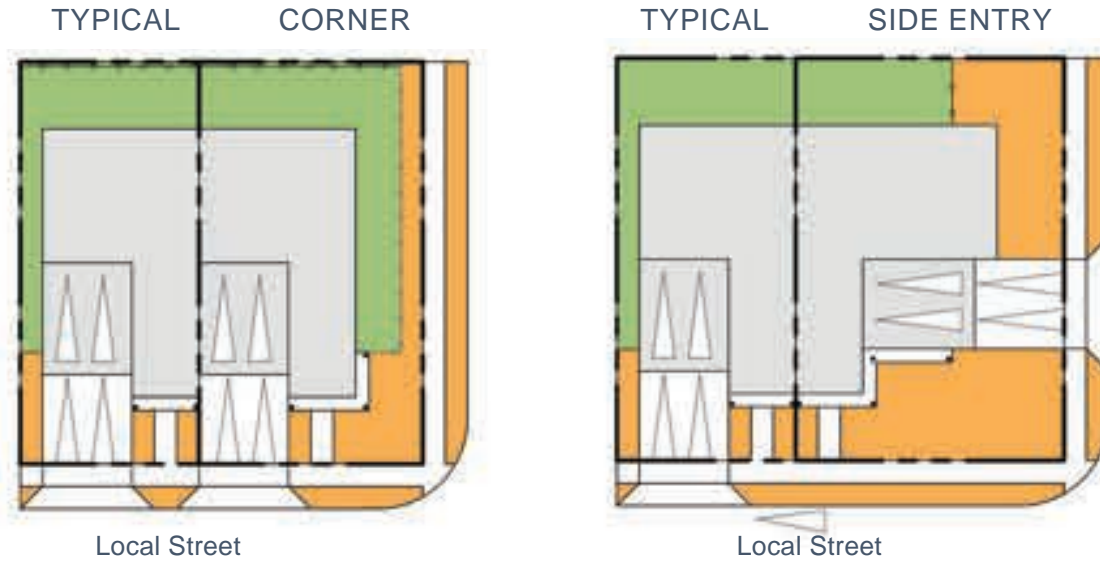
4.4.3 FRONT AND SIDE LOAD PAIRED HOMES

INSTALLATION AND MAINTENANCE REQUIREMENTS



-  Property Line
-  Five feet (5') Horizontal Privacy Fence
-  Landscaping installed by Builder and maintained by homeowner or sub-association
-  Landscaping installed by homeowner or builder and maintained by homeowner



REQUIRED PLANTING AND TYPICAL LOT PLANTING DESIGN

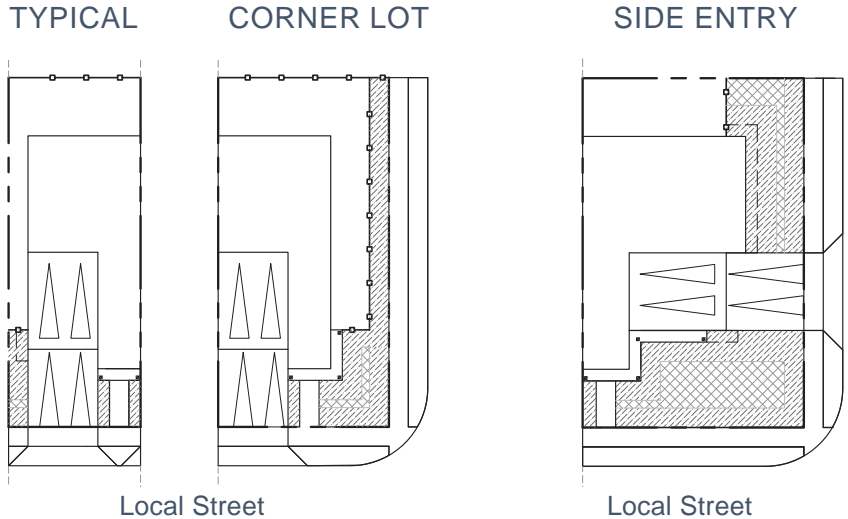

- Flex Zone
- Minimum Planting Bed
- 3' No Irrigation Zone line
- Five feet (5') Horizontal Privacy Fence
- Property Line

Minimum Required Quantities By Lot Type and Location					
	Typical Lot	Corner Lot		Side Entry	
Material	Front Yard	Front Yard	Side Yard	Front Yard	Side Yard
Parkway Trees	0	0	0	1	0
Evergreen Shrubs	1	1	3	1	3
Deciduous Shrubs/ Ornamental Grasses/ Perennials	5	3	5	5	5

*The Street Tree required by the City of Fort Collins meets the requirement for the Front Yard Tree
Refer to approved plans for required minimum tree sizes.

NOTES:

1. Turf may have undulating form, but should not be narrower than five feet (5') in any area. Turf and bed line should meet adjacent home turf and bed lines when possible.
2. Maintain three foot (3') no irrigation zone around principal structure per geotechnical recommendations. Required five foot (5') planting bed does not include three foot (3') no irrigation zone.
3. Flex zone allows homeowner to choose to expand either turf or planting bed areas.
4. Side yard incorporates area adjacent to side fencing and must meet a minimum of eighty percent (80%) coverage of live landscape material at least three feet (3') in height.
5. A diversity of plant types must be incorporated in all planting beds. No more than 25% of the same species of live shrubs, ornamental grasses, or perennials, shall be planted.
6. Variations from required planting may be approved by the Architectural Review Committee on an individual basis.

4.4.4 ALLEY LOADED PAIRED HOMES

INSTALLATION AND MAINTENANCE REQUIREMENTS



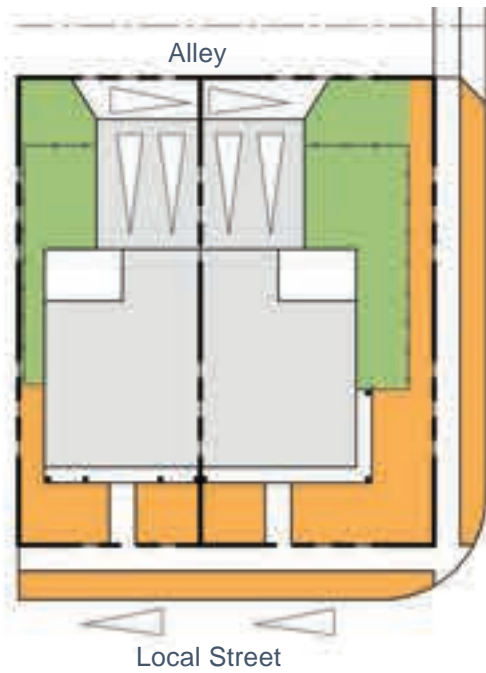

REQUIRED PLANTING AND TYPICAL LOT PLANTING DESIGN

TYPICAL CORNER LOT

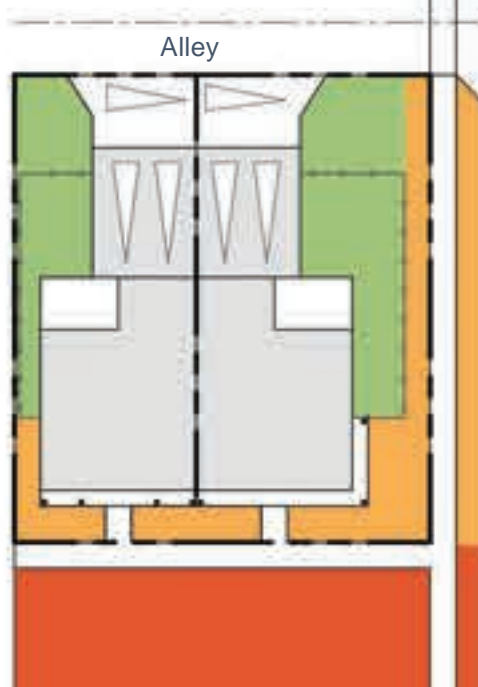

GREENCOURT



-  Property Line
-  Five feet (5') Horizontal Privacy Fence
-  Landscaping installed by District or Builder and maintained by District or sub-association
-  Landscaping installed by Builder and maintained by homeowner
-  Landscaping installed by homeowner or builder and maintained by homeowner



REQUIRED PLANTING AND TYPICAL LOT PLANTING DESIGN

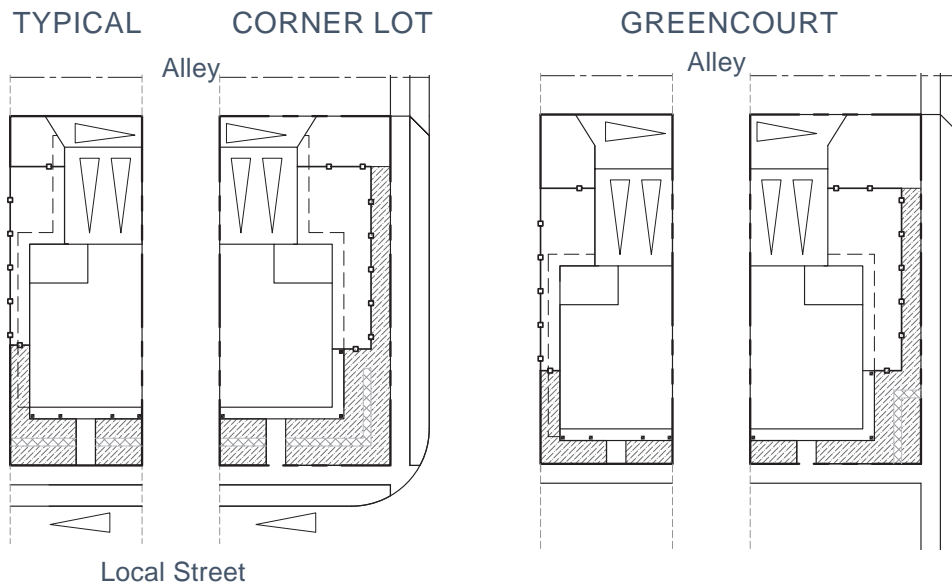

- Flex Zone
- Minimum Planting Bed
- Property Line
- Five feet (5') Horizontal Privacy Fence
- 3' No Irrigation Zone Line

Material	Minimum Required Quantities By Lot Type and Location				
	Typical Lot Front Yard	Corner Lot		Lot Adjacent to Greencourt	
	Front Yard	Front Yard	Side Yard	Front Yard	Side Yard
Ornamental Tree or Sm. Evergreen Tree	0	0	0	1	0
Evergreen Shrubs	1	1	4	4	3
Deciduous Shrubs/ Ornamental Grasses/ Perennials	5	4	4	5	5

*The Street Tree required by the City of Fort Collins meets the requirement for the Front Yard Tree
Refer to approved plans for required minimum tree sizes.

NOTES:





1. Turf may have undulating form, but should not be narrower than five feet (5') in any area. Turf and bed line should meet adjacent home turf and bed lines when possible.
2. Maintain three foot (3') no irrigation zone around principal structure per geotechnical recommendations. Required five foot (5') planting bed does not include three foot (3') no irrigation zone.
3. Flex zone allows homeowner to choose to expand either turf or planting bed areas.
4. Side yard incorporates area adjacent to side fencing and must meet a minimum of eighty percent (80%) coverage of live landscape material at least three feet (3') in height.
5. A diversity of plant types must be incorporated in all planting beds. No more than 25% of the same species of live shrubs, ornamental grasses, or perennials, shall be planted.
6. Variations from required planting may be approved by the Architectural Review Committee on an individual basis.

4.4.5 COTTAGES

INSTALLATION AND MAINTENANCE REQUIREMENTS

REQUIRED PLANTING AND TYPICAL LOT PLANTING DESIGN



-  Property Line
-  3-Rail Fencing
-  Landscaping installed by District or Builder and maintained by District or sub-association
-  Landscaping installed by Builder and maintained by homeowner
-  Landscaping installed by homeowner or builder and maintained by homeowner

NOTE:

1. SFD for-rent may have other site plan layouts with units that do not face the street and may instead be organized around green courts or other site elements and may have landscaping that is fully owned and maintained by a sub-association.



REQUIRED PLANTING AND TYPICAL LOT PLANTING DESIGN

TYPICAL:

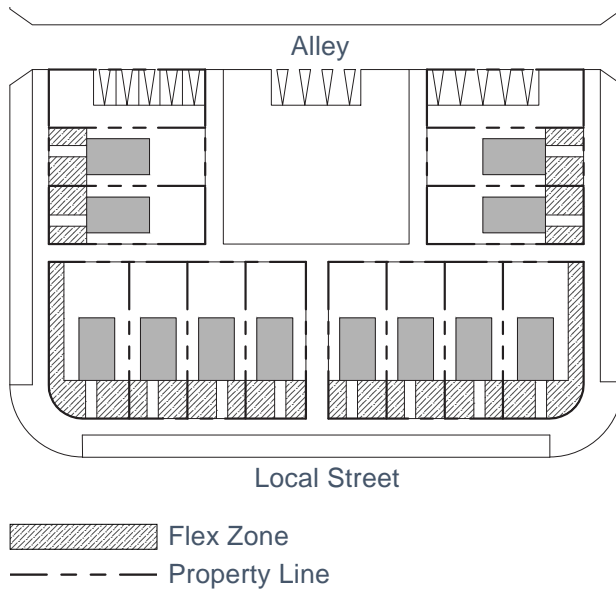

Minimum Required Quantities By Lot Type and Location			
Material	Corner Lot		Typical Lot
	Front Yard	Side Yard	Front Yard
Ornamental Tree or Sm. Evergreen Tree	Parkway Trees	Parkway Trees	Parkway Trees
Evergreen Shrubs	1	1	1
Deciduous Shrubs/ Ornamental Grasses/ Perennials	3	3	5

*The Street Tree required by the City of Fort Collins meets the requirement for the Front Yard Tree. Refer to approved plans for required minimum tree sizes.

NOTES:

1. Turf may have undulating form, but should not be narrower than five feet (5') in any area. Turf and bed line should meet adjacent home turf and bed lines when possible.
2. Maintain three foot (3') no irrigation zone around principal structure per geotechnical recommendations. Required five foot (5') planting bed does not include three foot (3') no irrigation zone.
3. Flex zone allows homeowner to choose to expand either turf or planting bed areas.
4. Side yard incorporates area adjacent to side fencing and must meet a minimum of eighty percent (80%) coverage of live landscape material at least three feet (3') in height.
5. A diversity of plant types must be incorporated in all planting beds. No more than 25% of the same species of live shrubs, ornamental grasses, or perennials, shall be planted.
6. Variations from required planting may be approved by the Architectural Review Committee on an individual basis.

4.5 BLOOM SIGNATURE PLANT LIST

A minimum of fifty percent (50%) of the species selected by the homeowner shall be made up of Bloom Signature Plants

For proper plant growth, Colorado soils shall be amended with organic material. A minimum of three cubic yards of organic material shall be added to topsoil per one-thousand (1000) square feet of planting area. Organic material shall be aged compost; wood humus from soft, non-toxic trees. Proper amendments as specified will improve drainage and, as a result, conserve water. Plants will flourish and live longer, healthier lives. A soil analysis should be performed prior to planting for proper micro nutrient recommendations.

*Aspen tree varieties are not recommended due to their limited hardiness in this zone. Check with local nurseries for additional tree options that are well-suited for this region.

Some lot sizes within Bloom may not accommodate larger canopy or diameter trees or shrubs. Ensure that plants are being selected that will fit within available space as to not create any conflicts with fencing or surrounding buildings. Upright growth trees and shrubs that might work well in smaller spaces.

In order to support larger pollinator master plan goals within Bloom, a variety of plant species in each landscape area are encouraged, to include deciduous, evergreen, perennials and ornamental grasses. Pollinator supporting species are noted with an asterisk *. Detailed information on Bloom’s Pollinator Master Plan and goals for pollinator habitat can be found in the Appendix of this document.

Common Name	Latin Name	HT / WD
Deciduous Trees		
Bigtooth Maple	<i>Acer Grandidentatum</i>	25-35'/15-25'
Green Mountain Sugar Maple*	<i>Acer saccharum</i> 'Green Mountain' TM	40-50'/25-35'
Redmond American Linden*	<i>Tilia americana</i> 'Redmond'	40-50'/25-35'
Texas Red Oak	<i>Quercus buckleyi</i>	25-35'/15-25'
Western Hackberry*	<i>Celtis occidentalis</i>	40-50'/25-35'
Ornamental Trees		
Flame Amur Maple*	<i>Acer ginnala</i> 'Flame'	15-25'/15-20'
American Plum*	<i>Prunus americana</i>	10-20'/15-20'
Native Chokecherry*	<i>Prunus virginiana</i>	10-20'/10-15'
Gambel Oak*	<i>Quercus gambellii</i>	15-40'/15-25'
Evergreen Trees		
Black Hills Spruce*	<i>Picea glauca</i> 'Densata'	25-40'/15-25'
Ponderosa Pine	<i>Pinus ponderosa</i>	>65' /25-40'
Bakeri Spruce	<i>Picea pungens</i> 'Bakeri'	30-40'/15-20'
Northstar White Spruce	<i>Picea glauca</i> 'North Star'	10-15'/3-6'
Colorado Blue Spruce Baby Blue Eyes*	<i>Picea pungens</i> 'Baby Blue Eyes'	20-30'/10-15'
Tannenbaum Mugo Pine*	<i>Pinus mugo</i> 'Tannenbaum'	10-15'/5-10'
Spartan Juniper*	<i>Juniperus chinensis</i> 'Spartan'	10-15'/3-6'
Evergreen Shrubs		
Bar Harbor Creeping Juniper	<i>Juniperus horizontalis</i> 'Bar Harbor'	6-18"/5-8'
Cranberry Cotoneaster	<i>Cotoneaster apiculatus</i>	12-24"/3-6'
Dwarf Pinon Pine	<i>Pinus edulis</i>	20-30'/10-20'
Humpy Mugo Pine	<i>Pinus mugo</i> 'Humpy'	2-3'/3-5'
Panchito Manzanita*	<i>Arctostaphylos</i> 'Panchito'	18-36"/3-5'



Common Name	Latin Name	HT / WD
Large Deciduous Shrubs		
Arctic Fire Dogwood*	<i>Cornus sericea</i> 'Arctic Fire'	4-6'/4-6'
Black Chokeberry*	<i>Aronia melanocarpa</i>	5-7'/4-6'
Cheyenne Mockorange*	<i>Philadelphus lewisii</i> Cheyenne®	6-9'/5-8'
Northern Gold Forsythia*	<i>Forsythia</i> 'Northern Gold'	5-8'/5-7'
Peking Cotoneaster*	<i>Cotoneaster acutifolius</i>	6-8'/4-6'
Double Flowering Plum*	<i>Prunus triloba</i>	10-12'/8-10'
Saskatoon Serviceberry*	<i>Amelanchier alnifolia</i>	4-15'/6-8'
Medium Deciduous Shrubs		
Apache Plume*	<i>Fallugia paradoxa</i>	4-8'/4-6'
Black Chokeberry*	<i>Aronia melanocarpa</i>	5-7'/4-6'
Compact Burning Bush	<i>Euonymus alatus</i> 'Compactus'	4-8'/4-8'
Dwarf Flowering Almond*	<i>Prunus glandulosa</i> 'Alba' 'Rosea Plena'	4-6'/4-6'
Golden Currant*	<i>Ribes aureum</i>	4-6'/4-6'
Japanese Barberry	<i>Berberis thunbergii</i>	4-6'/4-7'
Vanhoutte Spirea 'Renaissance'*	<i>Spirea x vanhouttei</i>	5-6'/6-7'
Western Sand Cherry*	<i>Prunus bessyi</i>	4-6'/4-7'
Small Deciduous Shrubs		
Baby Spice Viburnum*	<i>Viburnum carlesii</i>	4-6'/1-2'
Golden Rocket Barberry*	<i>Berberis thunbergii</i> 'Golden Rocket'	3-5'/2-3'
Kelsey Dogwood*	<i>Cornus sericea</i> 'Kelseyi'	2-3'/2-3'
Little Princess Japanese Spirea*	<i>Spirea japonica</i> 'Little Princess'	2-3'/2-3'
Autumn Sunblaze Miniature Rose*	<i>Rosa</i> 'Autumn Sunblaze'	1-2'/1-2'
Gold Finger Potentilla*	<i>Potentilla fruticosa</i> 'Gold Finger'	3-4'/3-4'
MiniMan Dwarf Manchurian Viburnum*	<i>Viburnum burejaeticum</i> 'P017S'	4-6'/4-6'
Sunburst St Johns Wort*	<i>Hypericum frondosum</i> 'Sunburst'	3-4'/3-4'
Ornamental Grasses		
Blue Avena Grass	<i>Helictotrichon sempervirens</i>	2-3'/2-3'
Blonde Ambition Grama Grass*	<i>Bouteloua gracilis</i> 'Blonde Ambition'	2-3'/2-3'
Feather Reed Grass	<i>Calamagrostis x acutiflora</i> 'Karl Forester'	3-5'/3-5'
Indian Rice Grass*	<i>Achnatherum hymenoides</i>	1-3'/1-2'
Northern Sea Oats	<i>Chasmanthium latifolium</i>	2-5'/1-2'
Prairie Drop Seed*	<i>Sporobolus heterolepis</i>	1-3'/2-3'
Switch Grass*	<i>Panicum virgatum</i>	1-3'/2-3'
Tufted Hair Grass*	<i>Deschampsia cespitosa</i>	3-5'/1-2'
Undaunted Muhly Grass*	<i>Muhlenbergia reverchoni</i> 'Undaunted'	1-3'/1-2'
Perennials		
Autumn Joy Sedum*	<i>Sedum</i> 'Autumn Joy'	18-24"/18-24"
Blanket Flower*	<i>Gaillardia aristata</i>	24-30"/12-18"
Crystal River Veronica*	<i>Veronica</i> 'Reavis Crystal River'	2-3"/20-30"
Coral Bell Varieties*	<i>Heuchera</i> spp.	6-18"/12-36"
Dalmatian Daisy	<i>Tanacetum cinerariifolium</i>	16-20"/18-24"
Double Bubble Mint Hyssop	<i>Agastache cana</i> 'Double Bubble Mint'	24-36"/12-24"
Dianthus Varieties*	<i>Dianthus</i> spp.	6-18"/4-24"
Husker Red Penstemon*	<i>Penstemon digitalis</i> 'Husker Red'	24-36"/18-24"
Magnus Coneflower*	<i>Echinacea purpurea</i> 'Magnus'	30-36"/18-24"
Moonshine Yarrow*	<i>Achillea</i> 'Moonshine'	24-30"/18-24"
Perfect Storm Hibiscus*	<i>Hibiscus</i> 'Perfect Storm'	24-36"/48-60"
Prairie Coneflower*	<i>Ratibida columnifera</i>	24-36"/24-36"
Sonoran Sunset® Hyssop*	<i>Agastache cana</i> 'Sinning'	12-18"/12-18"
Iris Varieties*	<i>Iris</i> spp.	6-24"/6-24"
Hosta Varieties*	<i>Hosta</i> spp.	6-48"/18-60"

5.0 FENCING:

5.1 REQUIRED FENCING

Fencing at Bloom is required along side and rear lot lines. Fencing is also required generally parallel to the front property line, set back two feet (2') from the front plane of the home. Front yard fencing is not permitted. All fencing at Bloom shall be the fences included in this document, unless otherwise approved by the ARC. The fencing shown below is to be installed by the Homeowner or developer and shall be maintained by the Homeowner. Fencing built by the District will be maintained by the District.



5.1.1 3-PRIVACY FENCE

The details below and on the following pages depict the fencing types approved for general use on properties adjacent to open space and on Single Family Detached Front-Loaded homes or rear loaded cottages with ON-LOT garages. ARC approval is required for all fence changes. Should different materials need to be utilized due to material availability constraints or other issues, alternate designs must be submitted to the ARC for review and cannot be installed without written approval.

FENCE TYPE 1: FIVE FEET (5') HORIZONTAL PRIVACY FENCE (FOR ALL SINGLE FAMILY ON-LOT GARAGE APPLICATIONS)

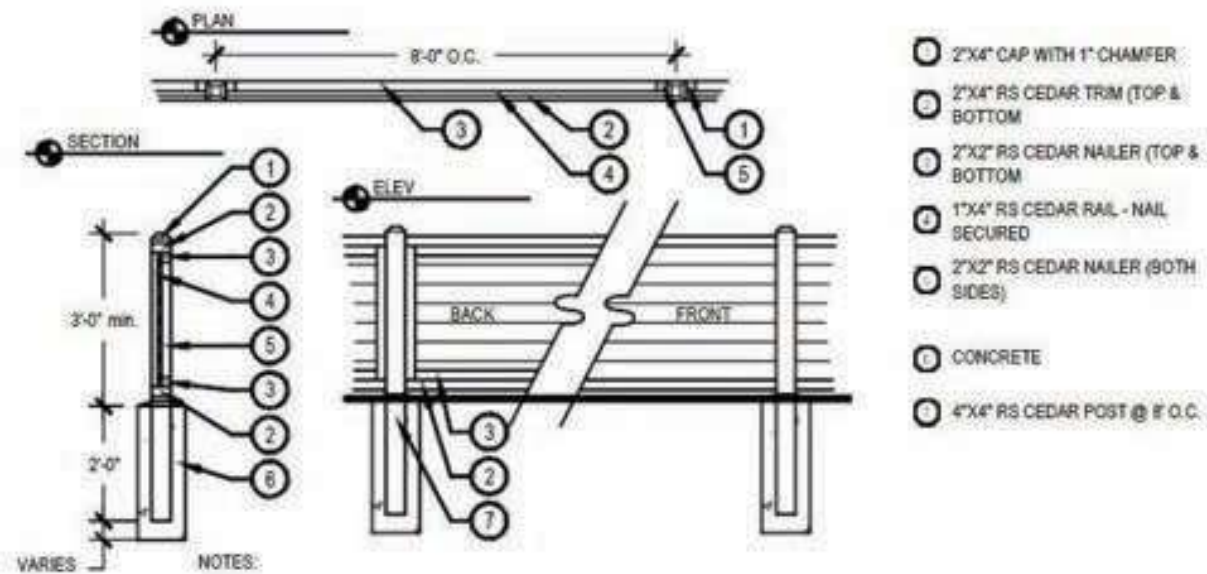

1. PLACE TOP & BOTTOM RAILS BARK SIDE UP.
2. RING SHANK OR SCREW SHANK NAILS SHOULD BE USED AT ALL CONNECTIONS.
3. GRADE CHANGES WILL REQUIRE A STEPPED FENCE, KEEPING ALL PICKETS HORIZONTAL.
4. SHERWIN WILLIAMS SUPER DECK, YOSEMITE GOLD, SOLID STAIN COLOR SW3048

60" - 5 FT. HORIZONTAL PRIVACY WOOD FENCE



IMAGE REPRESENTS FENCE TYPE, NOT COLOR

5.2 FENCING SETBACKS

1. Fences shall be set back from the front plane of the principal structure a minimum of two feet (2').
2. Where feasible, fencing in side yards parallel to the front property line on adjacent lots should generally align in order to provide a consistent and uniform appearance.
3. Fences shall be set back five feet (5') from public sidewalks

5.3 FENCING STANDARDS

1. All fencing materials shall be cedar or pressure treated lumber #1 Grade.
2. No front yard fencing is permitted.
3. Wing fences shall be set back a minimum two feet (2') from the front facade of house or garage.
4. All fencing must be stained Sherwin Williams Super Deck SW3048 Yosemite Solid Color Stain. No transparent stain is permitted.
5. All fence posts shall be four inches by six inches (4"x 6").

5.4 PET AREAS

1. Where approved by the ARC, small fenced pet areas may be permitted in the single family attached and/or multi-family portions of the site. See Dog Run/ Doghouses pg.13

5.5 RAILROAD FENCE TYPES

The details provided on the following pages are for use in District owned and maintained areas only and cannot be used for on-lot applications.



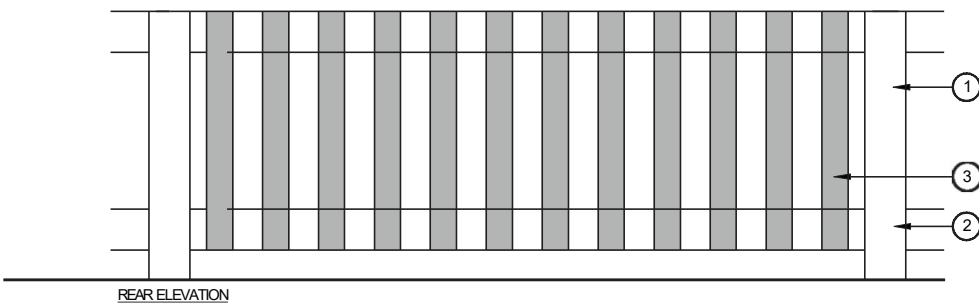
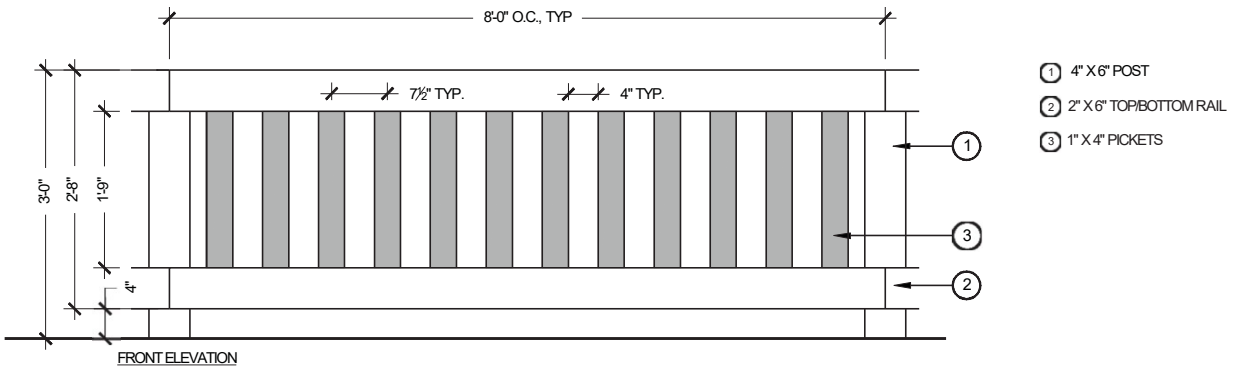

RAILROAD FENCING TYPE A

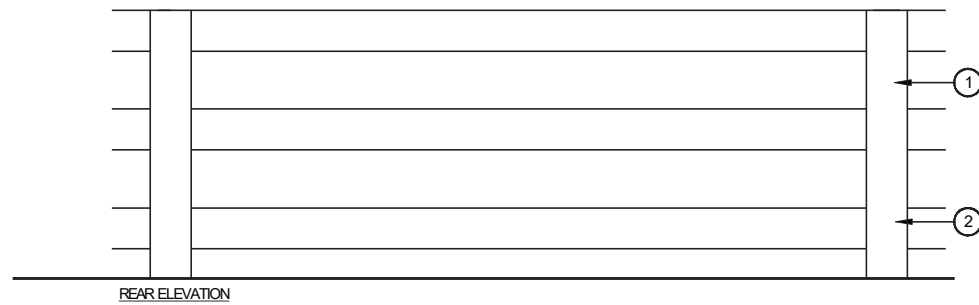
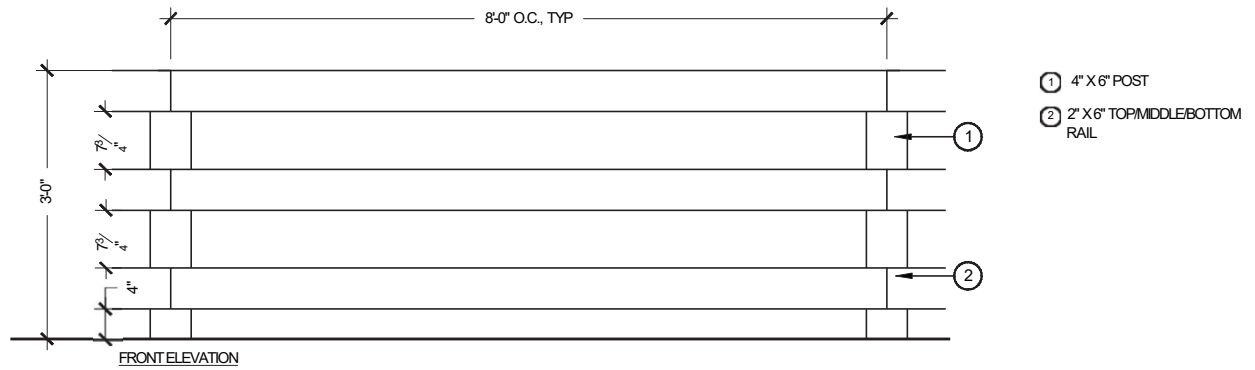

RAILROAD FENCING TYPE B

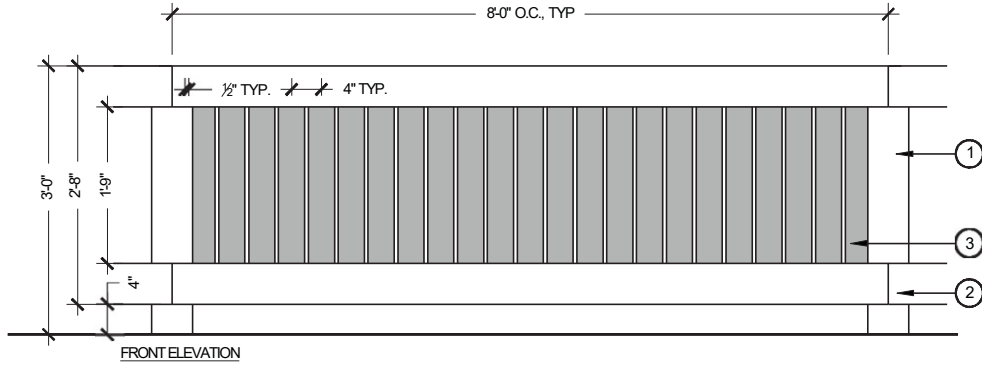

- ① 4" X 6" POST
- ② 2" X 6" TOP/BOTTOM RAIL
- ③ 1" X 4" PICKETS

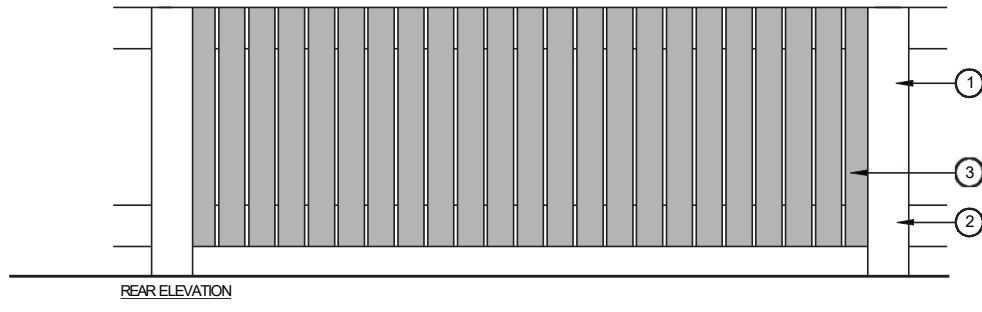

RAILROAD FENCING TYPE C



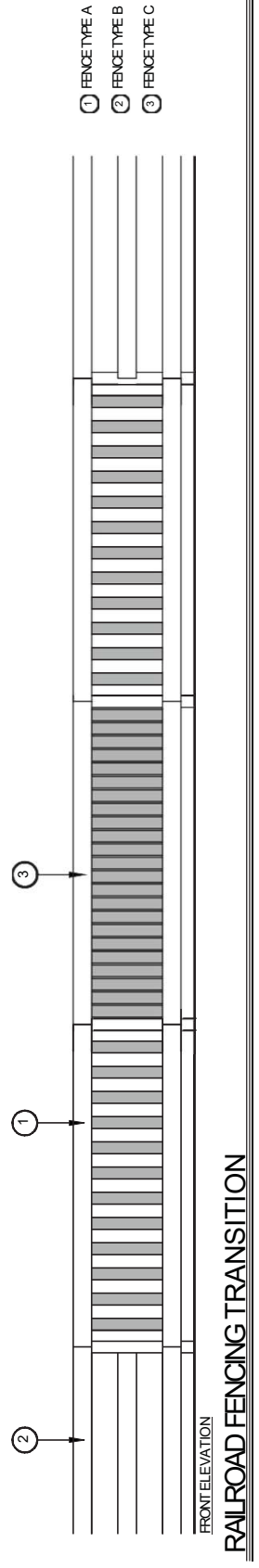

6.0 DEVELOPMENT AND BUILDER SIGNAGE:

6.1 SIGN LOCATIONS

No sign shall be erected in such a manner or location as to obstruct motorist, cyclist, or pedestrian vision, or obstruct the view of any traffic sign, signal or control device. All sign locations should be verified against approved plans to verify no utility conflicts. Should conflicts arise with any public utilities, utility locations will supersede sign locations and sign location or proportion will adjust accordingly. Verification of utility plans and field locates are required.

6.2 BUILDER SIGNAGE

Builder signs are temporary installations identifying individual home builders operating sales within the community. The list below identifies the types of signs that Builders may install. Builder signs shall conform to sign envelopes. Individual builders may include their corporate brand, font and logos on the Builder signs. Builder Signs will be located on Builder lots and sales areas. Developer reserves the right to determine if signage is inconsistent with the standards below. Developer must grant approval for any signs installed off Builder lots (within common areas). Once off-lot signs are authorized by Developer, Builder assumes all responsibility for damage to common area including irrigation lines in area where builder signage is granted approval to be installed per the Developer. Builder Signs must be maintained in upright position and remain professionally displayed. Worn or leaning signs will be removed at Developer's discretion.

ALLOWED BUILDER SIGNAGE

1. SALES OFFICE SIGN

Builders are allowed one sales office sign per sales office location. This sign is intended to contain information such as builder name/logo, collection information, contact info, pricing info, etc. The sign may be designed to conform with the builder brand look & feel. Sign may not exceed forty-eight (48) square feet per side. It is the responsibility of the builder to secure proper permits.

2. MODEL ID SIGN

Builders are allowed one model ID sign per model home location. This sign may conform with the builder brand look & feel.

3. A-FRAME SIGN

Builders are allowed up to two A-frame signs at their sales office location. A-frame signs may conform with the builder brand look & feel.

4. BOOTLEG/T-STAKE/WEEKENDER SIGNAGE

Smaller, temporary signage such as bootlegs/t-stake/weekenders) are not allowed within the community. The exception to this rule is if temporary signs are directing visitors to a special event (ie. Parade of Homes, special event, etc.). If that is the case, temporary signs may only be posted during the duration of the event.



5. FEATURE/SELLING POINTS SIGNAGE

Exterior signage declaring unique product selling points must be approved by Bloom's Development Company, Hartford Homes. This includes messaging such as energy efficiency, sustainability, safety and security call-outs.

6. FLAG POLES

One flag pole is allowed per Sales Office to fly an American flag and a builder logo flag. Flag pole height may not exceed fifty feet (50'). It is the responsibility of the builder to secure proper permits.

7. LOT/BLOCK, AVAILABLE, SOLD AND PRIVATE RESIDENCE SIGNS

Lot/Block, Available, Sold and Private Residence signs sign may conform with the builder brand look & feel.

8. CONSTRUCTION/JOB SITE SIGNAGE

Construction/Job Site Signs include information pertaining to builder job site guidelines/ requirements. Signs may not exceed thirty-two (32) square feet.

9. PROMOTIONAL SIGNAGE

Promotional signage is considered to be temporary additions to a builder's sales office/model area to draw attention to a special promotion or event, ie. flutter flags, balloons, banners, etc.

Promotional items are permitted following these guidelines:

- A. Flutter flags, balloons and banners cannot be excessive.
- B. Flutter flags, balloons, banners and other indication signal materials can only be used during timely events, and must be taken down within two days after event completion. For example, if you're hosting an event all day Saturday, these materials must be removed by close of business on Monday.
- C. Temporary banners promoting special pricing or other incentives may be fastened to trap fencing. Banners may be up for a maximum of thirty (30) days.

10. CLOUD BUSTER BALLOONS

A maximum of two cloud buster balloons are permitted per sales office location.

11. OFF SITE SIGNAGE

Any signage that is placed on property not owned by the Builder will need to be approved by Hartford Homes. Builders may pursue offsite signage with private landowners as desired or as allowed by the applicable municipality

7.0 POLLINATOR RECOMMENDATIONS

The Bloom community fully supports the establishment of landscape designs and maintenance practices that support pollinator species and habitat. The information provided in these design guidelines is for reference only and implementation of pollinator-friendly elements on private lots is highly encouraged but not required. Information and resources are provided below and in the Appendix to assist residents in creating effective and lasting pollinator habitat.

7.1 CONCEPT NARRATIVE AND SIGNIFICANCE

1. The Bloom community was approved by the City of Fort Collins with a Pollinator Master Plan that supports and promotes pollinator habitat throughout the community. Pollinator plantings will be an integral part of the Bloom landscape character and contribute to the overall aesthetic and quality of life within Bloom.
2. The approved overall pollinator concept within Bloom is to establish a framework for a well-connected pollinator network throughout the community. The approved Pollinator Master Plan is included for reference in the Appendix of this document.
3. The pollinator network will support the city’s larger goal of utilizing the Cooper Slough as a north-south pollinator corridor within northeast Fort Collins. A series of internal corridors will run both north-south and east-west within bloom to connect pollinators throughout bloom and to the Cooper Slough. A flexible system of pollinator nodes will be integrated throughout developed urbanized areas and open space. Pedestrians will be able to learn about and experience pollinators as they use bloom’s internal trail system and sidewalks. Pollinator nodes will also support an enhanced landscape aesthetic throughout bloom, providing seasonal color and interest while providing pollinator habitat. The average foraging distance for native pollinators ranges from approximately fifty (50) feet to one-half (½) mile. The optimal foraging distance for nonnative pollinators, such as the European honey bee, is approximately one mile or less from the colony. The proposed concept plan and node locations support a diverse variety of pollinators.
4. Beyond areas identified on the Pollinator Master Plan, private landscapes have the ability to support the pollinator goals within Bloom. The recommended Bloom plant list included in section 4.5 of this document denotes specific species within the Bloom signature landscape palette that provide pollinator habitat.

PRIMARY POLLINATOR CORRIDOR:

Nodes of at least one-hundred (100) square feet each shall be provided at intervals of one-hundred (100) linear feet maximum.

SECONDARY POLLINATOR CORRIDOR:

Nodes of at least fifty (50) square feet each shall be provided at intervals of four-hundred (400) linear feet maximum.

PRIMARY POLLINATOR NODE:

Nodes shall include at least two (2) species that bloom throughout the growing season or at least one (1) species each blooming in spring, summer and fall.



SECONDARY POLLINATOR NODE:

Nodes shall include at least 1 species that blooms throughout the growing season or at least two species blooming in different seasons

- 5. Beyond areas identified on the Pollinator Master Plan, private landscapes have the ability to support the pollinator goals within Bloom. The recommended Bloom plant list included in section 4.5 of this document denotes specific species within the Bloom signature landscape palette that provide pollinator habitat.

7.2 INSTALLATION

GENERAL POLLINATOR INSTALLATION BEST PRACTICES INCLUDE THE FOLLOWING.

- > Plant in mild weather, avoid long periods of heat or frost.
- > Stage the plants in the planting area while they are still in their pots. This can help when creating a balance in plant. This can also be helpful to avoiding over planting by anticipating the plant’s mature size.
- > After transplanting it’s important to adequately water the plants until they are fully established.
- > Mulching around the plantings can help reduce evaporation and promote insulation.

7.3 MAINTENANCE

7.3.1 GENERAL

Pollinator maintenance practices shall be conducted to successfully establish plantings, create year-round habitat and promote diversity. Providing nesting and overwintering habitat is a critical component to establishing successful populations of pollinators. A successfully managed pollinator program can also benefit songbirds and a balanced urban ecosystem.

RECOMMENDED POLLINATOR MAINTENANCE PRACTICES:

1. Do not use chemical fertilizers, herbicides or insecticides.
2. Do not use weed-barrier fabric in areas approved by owner.
3. Do not trim perennials or grasses earlier than mid-April.
4. Trim stems of perennials to a height of six inches to eight inches (6”-8”) and leave in place until the next growing season.
5. Leave small bunches of cut stems within pollinator beds after trimming. Stems to be placed toward the back of the planting bed or dispersed in between plantings.
6. Leave any fallen leaves within pollinator beds through the next growing season. Collected leaves can also be placed in small piles in designated bloom open space areas to provide additional overwintering habitat.

7.3.2 RECOMMENDATIONS FOR PRIVATE LANDSCAPES

- > Do not use chemical fertilizers, herbicides or insecticides. Employ alternative non-lethal methods including but not limited to; Weeding, Neem Oil, Lime Sulfur, Horticulture Vinegar, Boric Acid,

Pyrethrum, Copper, etc.

- > The use of weed-barrier fabric in areas approved by owner is not recommended.
- > It is not recommended to trim perennials or grasses earlier than mid-April.
- > It is recommended to trim stems of perennials to a height of 6-8" above the base and leave in place until the next growing season.
- > It is recommended to leave small bunches of cut stems within pollinator beds after trimming. Stems can be placed toward the back of the planting bed or dispersed in between plantings.
- > It is recommended to leave any fallen leaves within pollinator beds through the next growing season.

7.3.3 PARKS, OPEN SPACE AND TRAIL CORRIDORS

- > Do not use chemical fertilizers, herbicides or insecticides.
- > Do not trim grasses and perennials prior to mid April.
- > Do not use weed barrier fabric in these areas
- > Trim stems of perennials to a height of six inches to eight inches (6"-8") and leave in place until the next growing season.
- > Leave small bunches of cut stems within pollinator beds after trimming. Stems to be placed toward the back of the planting bed or dispersed in between plantings.
- > Leave any fallen leaves within pollinator beds through the next growing season. Collected leaves can also be placed in small piles in designated Bloom areas to provide additional over-wintering habitat.
- > Planting beds within park areas may be subject to higher maintenance, debris from these plantings may be moved elsewhere.

7.3.4 PUBLIC RIGHTS-OF-WAY

- > Plantings within the public ROW shall be maintained per City of Fort Collins standards. Perennials, Shrubs and Grasses shall not exceed three feet (3') height within sight triangles.
- > Do not use chemical fertilizers, herbicides or insecticides.
- > Avoid trimming grasses and perennials prior to mid April.
- > Avoid the use of weed barrier fabric.
- > Trimming debris shall be removed from view. It may be placed outside of view within the planting bed or into small concentrated piles off the path of the trail system.

7.3.5 ARIA CORRIDOR

The Aria Corridor is an important spine that runs North-South within Bloom. For this reason the Aria Corridor will be maintained following more traditional practices.

- > Do not use chemical fertilizers, herbicides or insecticides.
- > Avoid trimming grasses and perennials prior to mid April.
- > Trimming debris shall be removed from the corridor. It may be placed into small concentrated piles off the path of the trail system.



- > Weed Barrier Fabric is permitted in this area.
- > It is recommended to trim stems of perennials to a height of six inches to eight inches (6"-8") and leave in place until the next growing season.

7.4 ADDITIONAL RESOURCES

There are a variety of resources providing useful information on the establishment of pollinator habitat and corridors. Please refer to the District's website for resources demonstrating best practices to maximize the value of pollinator plantings.



Native Shrubs for Colorado Landscapes

Fact Sheet No. 7.422

Gardening Series | Trees and Shrubs

by J. Klett, B. Fahey, R. Cox and I. Shonle*

Why Grow Native Shrubs?

There are many benefits to using Colorado native shrubs for home and commercial landscapes. Colorado native shrubs are naturally adapted to their specific Colorado climate, soils, and environmental conditions. When correctly sited, they can be ideal plants for a sustainable landscape that requires reduced external inputs such as watering, fertilizing, and pruning. In order to realize these benefits, the planting site must approximate the natural environmental conditions of the plant in its native habitat.

Another benefit of using Colorado natives in landscapes is that they may attract a wide variety of wildlife including mammals, birds, and butterflies. Rapid urbanization in the state is reducing biodiversity as habitat is removed for building and road construction. Landscaping with natives on a large or small scale can maintain biodiversity that otherwise could be lost to development.

The shrubs listed in Table 1 are grown by some Colorado nurseries and are becoming more available in the commercial sector. However, not all shrubs listed are available at all nurseries, so it may be necessary to contact a number of commercial outlets to find a specific plant. If a shrub is not sold in the trade, asking for it may help increase its availability. Native shrubs should not be collected from the wild because this reduces biodiversity and causes a disturbed area that may be invaded by weeds.

Most of the shrubs listed in Table 1 are available as container-grown plants. Native shrubs often do not have as great a visual impact in the container or immediately after planting as do traditional horticultural



Figure 1: Mountain-mahogany fruit (*Cercocarpus montanus*)

species. Over time, they will reward the homeowner with their natural beauty and other benefits.

Where To Grow Native Shrubs

There are several factors to consider in designing a native landscape. Due to Colorado's wide variation of elevation and topography, native plants are found in a variety of habitats. In order to maximize survival with minimal external inputs, plants should be selected to match the site's life zone and the plant's moisture, light, and soil requirements. Even if a plant is listed for a particular life zone, the aspect (north, south, east or west facing) of the proposed site should match the moisture requirement. For example, a red twig dogwood, which has a high moisture requirement, should not be sited with plants of dissimilar water needs. Similarly, a red twig dogwood should not be planted on a south-facing slope, where a significant amount of additional moisture would be required.

Growing native shrubs does not exclude the use of adapted non-native plants. There are many non-native plants that are adapted to Colorado's climate and can be used in a native landscape as long as moisture, light, and soil requirements are

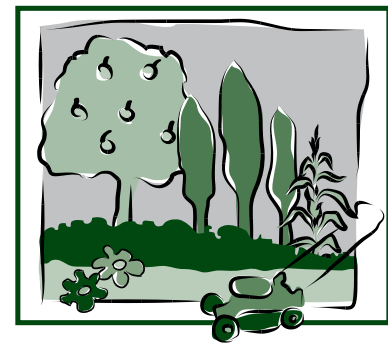

Quick Facts

- A Colorado native shrub can be described as existing in Colorado prior to European settlement.
- Native plant communities make Colorado visually distinct from the eastern, southern or western United States.
- Native plant gardens are wildlife habitats and each plant contributes to the biodiversity of the state.
- Landscaping with natives on a large or small scale can maintain biodiversity that otherwise would be lost to development.

© Colorado State University Extension. 6/02. Revised 1/18.
extension.colostate.edu



*J. Klett, Colorado State University Extension landscape and horticulture specialist; B. Fahey, Jefferson County Extension natural resources/horticulture agent; R. Cox, Arapahoe County Extension horticulture agent (retired), and I. Shonle, Gilpin County Extension Director/Agent. 1/2018





Figure 2: Golden currant (*Ribes aureum*)



Figure 3: Twinberry fruit (*Lonicera involucrata*)



Figure 4: Red-berried elder (*Sambucus racemosa*)



Figure 5: Wild rose (*Rosa woodsii*)

similar. Even if a site has a non-native landscape that requires additional inputs (such as an irrigated landscape on the plains), dry land native plants can be used in non-irrigated pockets within the non-native landscape. These native “pocket gardens” can be located in areas such as parkways and next to hardscapes that are difficult to irrigate.

Some communities regulate landscape appearance or the type of plants which may be used. So before completing a landscape design, check with local authorities, including

homeowner’s associations, to discover any regulations that may affect your design.

Life Zones of Colorado

Colorado can be divided into five life zones that are broadly defined by the plant communities that occur at the approximate elevations described below. The Plains life zone, 3,500 to 5,500 feet, is located in eastern Colorado where the majority of Colorado’s population resides. It is dominated by grasslands and streamside cottonwoods. In western Colorado, the Upper Sonoran life zone is located at altitudes below 7,000 feet, and in the San Luis Valley, below 8,000 feet. This zone is characterized by semidesert shrublands and piñon pine-juniper woodlands at its upper limit.

The Foothills life zone occurs from 5,500 to 8,000 feet and is dominated by dry land shrubs such as Gambel oak and mountain-mahogany, and, in southern and western Colorado, piñon-juniper woodlands and sagebrush. The Montane zone consists of ponderosa pine, Douglas-fir, lodgepole pine, and aspen woodlands at elevations of 8,000 to 9,500 feet. Dense forests of subalpine fir and Engelmann spruce dominate the Subalpine zone at 9,500 to 11,500 feet. The Alpine zone above 11,500 feet is a treeless zone made up of grasslands called tundra. Species requiring medium to high moisture occur along watercourses throughout all zones.

Culture and Maintenance

Successful establishment of native shrubs may require supplemental moisture after planting. Once established, the watering frequency can be reduced or even eliminated if the plant was sited in its native environmental conditions. Container-grown shrubs can be planted at any time during the growing season. Container-grown native shrubs are often grown in a soilless mixture of peat and bark, so the planting site should be amended with some organic material. Another option would be to carefully wash off the media from the container grown plant and plant it bare root.

Using native shrubs offers many benefits in addition to reduced maintenance. Natives are part of our natural heritage and the ecosystems of

Colorado. Native plant communities make Colorado visually distinct from the eastern, southern or western United States. Native plant gardens are wildlife habitats and each plant contributes to the biodiversity of the state.



Figure 6: Western chokecherry (*Prunus virginiana melanocarpa*)



Figure 7: Wax currant (*Ribes cereum*)



Figure 8: Waxflower (*Jamesia americana*)



Figure 9: Serviceberry (*Amelanchier alnifolia*)

Table 1. Native shrubs for Colorado landscapes.

Scientific Name ¹	Common Name(s)	Planting Altitude in feet ²	Native Colorado Life Zone ³	Moisture ⁴	Evergreen/Deciduous	Comments ⁵
Large shrubs (6 - 10 ft when mature)						
<i>Acer glabrum</i>	Rocky Mountain maple	5,000 - 10,500	Foothills - Montane	L - M	D	Small, rounded tree to large shrub; usually multi-stemmed; smooth, gray branches with red buds; fall foliage yellow; shade tolerant. Upright to spreading branches; small, rounded leaves; clusters of small white flowers; blue-black fruit attractive to wildlife; orange to red fall color.
<i>Amelanchier alnifolia</i>	serviceberry	5,000 - 10,000	Foothills - Subalpine	L - M	D	
<i>Cercocarpus ledifolius</i>	curl-leaf mountain-mahogany	4,500 - 9,000	Upper Sonoran ^{3a}	L - M	E	Thick, dark evergreen leaves curl during drought conditions; feathery, attractive seed heads; irregular growth habit; large shrub to small tree.
<i>Cercocarpus montanus</i>	mountain-mahogany	4,000 - 8,500	Foothills - Montane	L - M	D	Open growth habit; feathery, attractive seed heads; wedge-shaped leaves.
<i>Cornus sericea</i>	red twig dogwood; red-osier dogwood	4,500 - 10,000	Plains - Montane	M - H	D	Red stems in winter; flat, white flower clusters followed by white to blue fruits attractive to birds; yellow to red fall color; streamside understory plant; shade tolerant.
<i>Cowania stanshurianna</i>	Cliffrose	4,000 - 7,500	Upper Sonoran ^{3a}	L	E	Large oval shrub; rigid, gnarled branches; small, lobed olive green leaves, fragrant, creamy colored flowers, followed by feather-tailed seeds.
<i>Forestiera neomexicana</i>	New Mexico privet	4,500 - 7,500	Upper Sonoran ^{3a}	L	D	Large shrub to small tree; dense, grayish-green foliage; yellow flowers before leaves; blue-black fruit on females; light tan bark; yellow fall color; good for screening.
<i>Fraxinus anomala</i>	single-leaf ash	4,500 - 6,000	Upper Sonoran ^{3a}	L - M	D	Large shrub or small tree, often multi-stemmed; found in dry canyons in southwest CO; yellow fall color; less available.
<i>Mahonia fremontii</i>	Fremont mahonia	4,500 - 7,000	Upper Sonoran ^{3a}	L	E	Large shrub, often multi-stemmed; blue holly-like leaves, fragrant yellow flowers in spring followed by red berries.
<i>Peraphyllum ramosissimum</i>	Squaw apple	5,500 - 9,000	Upper Sonoran ^{3a}	L	D	Shrub with fragrant white flowers in spring followed by crabapple-like fruit.
<i>Prunus americana</i>	American plum, wild plum	4,500 - 8,500	Plains - Foothills	L - M	D	Thicket-forming; white flowers before leaves; fruit good for preserves; attracts wildlife; cold and drought tolerant; yellow to red fall color; found along canyons and slope bottoms.
<i>Prunus pennsylvanica</i>	pin cherry	5,000 - 8,000	Foothills ^{3b}	M	D	Large shrub to small tree; thicket-forming; shiny, green leaves; red, edible fruit; shade tolerant; white flowers; red fall color.
<i>Prunus virginiana melanocarpa</i>	Western chokecherry	4,500 - 8,500	Plains - Montane, Upper Sonoran	M	D	Irregular, branching shrub with shiny, dark green leaves and elongated flower clusters; suckers to form thickets; dark purple fruit excellent for preserves; reddish-orange to yellow fall color.
<i>Ptelea trifoliata</i>	hop tree, wafer-ash	4,000 - 6,500	Plains - Foothills ^{3b}	M - H	D	Shrub or small tree with three-parted foliage; drought and shade tolerant; small, fragrant flowers; yellow fall color; persistent hop-like fruit.
<i>Quercus undulata</i>	wavyleaf oak	4,000 - 6,500	Foothills ^{3b}	L	D - E	Blue-green, leathery leaves with wavy edges; leaves persist in winter; coarse bark; native to southeast CO; less available.
<i>Rhamnus smithii</i>	Smith buckthorn	5,000 - 7,500	Foothills ^{3a}	L - M	D	Upright habit with dark green shiny leaves; black fruit in late summer on female plants; yellow fall color; good screen plant; Plant Select ^{®5a} .
<i>Rhus glabra</i>	smooth sumac	4,000 - 8,000	Plains - Foothills, Upper Sonoran	L - M	D	Open, rounded thicket-forming shrub; bright green leaves; pyramidal clusters of yellow flowers produce fuzzy, dark red fruits in fall that persist into winter; outstanding yellow-orange-red fall color.
<i>Robinia neomexicana</i>	New Mexico locust	4,500 - 9,000	Foothills	L - M	D	Thicket-forming thorny shrub, green leaves; showy pink flowers in the spring.
<i>Salix exigua</i>	sandbar willow	4,000 - 9,000	Plains - Foothills, Upper Sonoran	H	D	Thicket-forming; gray-green narrow leaves; salinity tolerant; yellowish-gray catkins before leaves; yellow fall color.
<i>Salix monticola</i>	Rocky Mountain willow, yellow mountain willow	6,000 - 10,500	Montane	H	D	Broad, rounded shrub; narrow, deep green leaves, yellow fall color; arching yellow twigs attractive in winter; common streamside willow found in mountain areas.



Table 1 (cont.). Native shrubs for Colorado landscapes.

Scientific Name ¹	Common Name(s)	Planting Altitude in feet ²	Native Colorado Life Zone ³	Moisture ⁴	Evergreen/Deciduous	Comments ⁵
<i>Shepherdia argentea</i>	silver buffaloberry	4,500 - 7,500	Plains - Foothills, Upper Sonoran	L - M	D	Thorny shrub to small tree; thicket-forming; silver, rounded leaves; golden to red, edible, bitter fruits on females; attracts wildlife.
<i>Sorbus scopulina</i>	native mountain-ash	6,000 - 10,000	Foothills - Subalpine	M	D	Large shrub to small tree with divided leaves; white flower clusters followed by orange fruit; attractive to wildlife; orange to red fall color; found in moist sites on slopes in rocky canyons.
Medium shrubs (4 - 6 ft when mature)						
<i>Amelanchier utahensis</i>	Utah serviceberry	5,000 - 9,000	Upper Sonoran ^{3a}	L-M	D	Thicket-forming shrub with fragrant white flowers in spring; edible blue berries in summer; attracts wildlife; yellow fall foliage.
<i>Amorpha fruticosa</i>	false indigo, leadplant	3,500 - 6,000	Plains ^{3b}	L	D	Open, wide-spreading shrub; feathery, green foliage; spikes of deep blue flowers in summer; yellow fall color; deer resistant.
<i>Artemisia tridentata</i>	big sagebrush	4,500 - 9,500	Upper Sonoran	L	E	Silver-colored evergreen with peeling grayish bark; leaves densely hairy and aromatic; wildlife browse plant; does not tolerate high moisture.
<i>Betula glandulosa</i>	bog birch	5,000 - 11,000	Subalpine	H	D	Globe-shaped shrub with small, rounded dark green leaves on reddish-brown erect stems; yellow to red fall color; better at higher altitudes.
<i>Fallugia paradoxa</i>	Apache plume	3,500 - 8,000	Plains, Upper Sonoran ^{3b}	L	D - E	Open, rounded shrub; small, grayish-green leaves; whitish, shreddy bark; white, rose-like flowers; fuzzy, pink seed heads appear all summer; native to San Luis and Arkansas Valleys; Plant Select ^{®5a} .
<i>Fendlera rupicola</i>	cliff fendlerbush	4,000 - 8,000	Upper Sonoran ^{3a}	L	D	Small, grayish-green, narrow leaves with edges rolled under; white to pink flowers; reddish-tan bark; less available.
<i>Holodiscus dumosus</i>	rock-spirea, mountainspray	5,000 - 10,000	Foothills - Montane	L - M	D	Upright shrub; arching, slender branches with pyramidal sprays of white flower clusters that turn rust; fall foliage colored bronze-red; sun to partial shade; found on rock outcrops and cliff bases.
<i>Purshia tridentata</i>	antelope bitterbrush, antelope-brush	5,000 - 9,000	Foothills - Montane	L	D	Spreading shrub with small, oval leaves and pale-yellow flowers in early summer; requires dry, coarse soils; important browse plant for wildlife.
<i>Rhus trilobata</i>	three-leaf sumac, skunkbush	3,500 - 9,000	Plains - Foothills, Upper Sonoran	L	D	Arching branches with glossy, green, three-parted leaves; small yellow flowers before leaves; reddish, hairy, edible fruits; orange to red fall color.
<i>Ribes aureum</i>	golden currant	4,000 - 10,000	Plains - Foothills, Upper Sonoran	L - M	D	Arching growth habit; yellow flowers in late spring; yellow to black fruit attracts birds; well-drained sites; orange to red fall color.
<i>Ribes cereum</i>	wax currant	4,000 - 10,000	Foothills	L	D	Rounded growth form; lobed, leathery leaves; lacks spines; pink tubular flowers in spring; edible orange-red berries in summer; attracts birds.
<i>Ribes inerme</i>	whitestem currant	6,000 - 10,000	Foothills - Montane	M	D	Rounded growth habit; few if any spines; whitish stems becoming reddish-brown and flaky; small, pink flowers followed by edible, tart, wine-red fruit.
<i>Ribes lacustre</i>	bristly currant, swamp currant	8,000 - 10,000	Montane - Subalpine	H	D	Low-growing shrub with spines; lobed leaves; greenish-purple flowers in drooping clusters followed by bristly purple fruit; native along streams; browse plants for livestock and game.
<i>Rubus deliciosus</i>	boulder raspberry	4,500 - 9,000	Foothills	L - M	D	Arching growth habit with peeling, cinnamon colored bark; shade tolerant; spineless; large, white, rose-like flowers in spring followed by sparse raspberry-like fruits.
<i>Rubus parviflorus</i>	western thimbleberry	5,000 - 10,000	Montane	M - H	D	Large, maple-like leaves; white, rose-like flowers followed by edible fruits; best in shady, moist locations.
<i>Salix irrorata</i>	bluestem willow	5,000 - 9,000	Foothills	H	D	Rounded, upright shrub; spreading silver-blue twigs; glossy green linear leaves; yellow fall color.
<i>Sambucus racemosa</i>	red-berried elder	5,000 - 12,000	Foothills - Subalpine	M - H	D	Upright to arching growth form; shiny compound leaves; stout branches; white flower clusters in early summer followed by bright red berries; yellow fall color; found along streams; attracts birds.

Table 1 (cont.). Native shrubs for Colorado landscapes.

Scientific Name ¹	Common Name(s)	Altitude in feet ²	Colorado Life Zone ³	Moisture ⁴	Planting Native Evergreen/Deciduous	Comments ⁵
<i>Amorpha canescens</i>	silvery leadplant	3,500 - 7,500	Plains - Foothills ^{3b}	L	D	Erect, dense shrub with gray-green, fern-like foliage; tall spikes of violet-purple flowers in midsummer; tolerates drought and poor soils.
<i>Arctostaphylos patula</i>	manzanita, bearberry	6,000 - 9,000	Foothills - Montane ^{3a}	L	E	Spreading growth habit with dense foliage; mahogany-red stems; oval, bright green erect leaves; pink flowers in spring followed by dark brown, small apple-like fruits; does best on well drained soils.
<i>Arctostaphylos uva-ursi</i>	kinnikinnik	5,000 - 10,000	Foothills - Subalpine	L - M	E	Mat-forming evergreen with small oval leaves; pink urn-shaped flowers followed by red fruits; requires well-drained gravelly soils; attracts wildlife; needs light shade.
<i>Artemisia cana</i>	silver sagebrush	5,000 - 10,000	Montane	L - M	E	Mounding growth habit; branches become gnarled; aromatic, silver-gray leaves.
<i>Atriplex canescens</i>	fourwing saltbush	4,000 - 8,000	Plains, Upper Sonoran	L	D - E	Light green to gray small leaves; interesting four-winged fruits on female plants; tolerates poor or salty soils; slow-growing.
<i>Ceanothus fendleri</i>	Fendler ceanothus, mountain-lilac	5,000 - 9,000	Foothills - Montane	L	D	Spiny, low shrub with small, white flower clusters in late spring; wildlife browse plant; grows on coarse soils; less available.
<i>Ceratoides lanata</i>	winterfat	3,500 - 9,500	Plains, Upper Sonoran	L	D - E	Dense, erect shrub covered with white woolly fruits; grayish-green leaves persist in winter; excellent forage for wildlife.
<i>Chrysothamnus nauseosus</i>	rabbitbrush, rubber rabbitbrush	5,000 - 10,000	Plains - Foothills, Upper Sonoran	L	D	Size and growth habit varies with subspecies; narrow aromatic leaves; young stems green to silvery-gray; showy clusters of yellow flowers on new growth in late summer attract butterflies; can be aggressive.
<i>Jamesia americana</i>	waxflower	5,500 - 10,000	Foothills - Montane	M	D	Flat-topped shrub with upright branches; distinctly veined heart-shaped leaves with white undersides; shreddy, reddish bark; waxy, white flowers in late spring; red fall color; shade tolerant; needs well-drained soil.
<i>Juniperus communis</i>	common juniper	5,000 - 10,000	Foothills - Subalpine	L - M	E	Low-growing; needle-like leaves with whitish stripes; bluish-gray, berry-like fruit; shade tolerant; needs well-drained soil.
<i>Lonicera involucrata</i>	twinberry	5,000 - 11,000	Montane - Subalpine	M - H	D	Shade-tolerant upright oval shrub with erect branches; bright green leaves; creamy yellow trumpet-shaped flowers in pairs followed by black fruit enclosed in a red cup.
<i>Mahonia repens</i>	creeping Oregon grape-holly	5,000 - 9,500	Foothills - Montane	L - M	E	Low-growing; thicket-forming ground cover; blue-green leaves turn purplish in winter; yellow flowers followed by edible, blue grape-like fruit; shade tolerant; may winter burn in windy, exposed sites.
<i>Paxistima myrsinites</i>	Mountain lover	6,000 - 11,000	Foothills, Montane	M	E	Spreading to prostrate shrub with small leathery leaves and inconspicuous flowers. Tolerates shade.
<i>Philadelphus microphyllus</i>	littleleaf mock-orange	5,000 - 8,000	Foothills, Upper Sonoran	L - M	D	Rounded, compact slow-growing shrub with small gray-green leaves; fragrant white star-shaped flowers.
<i>Physocarpus monogynus</i>	mountain ninebark	5,500 - 10,000	Foothills - Montane	M	D	Interesting shreddy bark on older branches; white to rose-colored flowers in small heads; good wildlife cover; leaves resemble currant; yellow to maroon fall color; less available.
<i>Potentilla fruticosa</i>	shrubby cinquefoil	5,000 - 11,000	Montane - Subalpine	M	D	Open, rounded shrub; single yellow flowers throughout summer; many cultivated forms available from nurseries.
<i>Prunus besseyi</i>	Western sand cherry	3,500 - 8,500	Plains - Foothills ^{3b}	L - M	D	Upright, rounded open shrub with grayish-green leaves; numerous white, single, fragrant flowers followed by purplish-black fruits that attract birds; red fall color. 'Pawnee Buttes' is a low, spreading groundcover; Plant Select ^{®5a} .

Table 1 (cont.). Native shrubs for Colorado landscapes.



Scientific Name ¹	Common Name(s)	Planting Altitude in feet ²	Native Colorado Life Zone ³	Moisture ⁴	Evergreen/Deciduous	Comments ⁵
<i>Rosa woodsii</i>	Woods rose, wild rose	3,500 -10,500	Foothills - Subalpine	L - M	D	Spiny, dark reddish-brown stems; thicket-forming; dark green, compound leaf; single, large pink flowers in early summer; reddish-orange fruits; browse plant for wildlife.
<i>Shepherdia canadensis</i>	russet buffaloberry	5,000 -11,500	Montane - Subalpine	M	D	Prostrate to upright shrub; brown, thornless branches; dark green, oval leaves with russet-colored scales beneath; inconspicuous flowers followed by red to orange bitter fruit on females; attractive to wildlife; shade tolerant.
<i>Symphoricarpos albus</i>	snowberry	5,000 - 8,500	Foothills	L - M	D	Arching growth habit; thicket-forming; rounded, blue-green leaves; shade tolerant; pink, bell-shaped flowers in summer; large white berries in fall persist into winter; attracts birds and small mammals.

¹ As commonly sold in the trade. For equivalents, see botanical publications.

² Planting altitudes are estimates of where plants may be successfully grown as landscape plants. In many cases, species may be successfully planted at a lower zone with supplemental irrigation or a higher zone with protection.

³ Approximate life zone elevations: Plains - below 5,500 ft. in eastern CO; Upper Sonoran - below 7,000 ft. in western CO and below 8,000 ft. in San Luis Valley; Foothills - 5,500 - 8,000 ft.; Montane - 8,000 - 9,500 ft.; Subalpine - 9,500 - 11,500 ft.; Alpine - above 11,500 ft. Species requiring medium to high moisture occur along watercourses throughout all zones. For simplicity, life zones were taken from *Grassland to Glacier* by Mutel and Emerick, first edition, 1984. For a more detailed treatment of Colorado ecosystems, see second edition, 1992.

^{3a}Native to Western Slope; ^{3b}Native to Eastern Slope.

⁴ Moisture Requirement: L - Low, M - Moderate, H - High.

⁵ Except where noted, plants prefer full sun.

^{5a} Plant Select is a cooperative program of Colorado State University, Denver Botanic Gardens and the Green Industry with the purpose of introducing the very best plants for gardens from the High Plains and beyond.

Colorado State University, U.S. Department of Agriculture and Colorado counties cooperating. CSU Extension programs are available to all without discrimination. No endorsement of products mentioned is intended nor is criticism implied of products not mentioned.

This page intentionally left blank.



This page intentionally left blank.

Native Herbaceous Perennials for Colorado Landscapes

Fact Sheet No. 7.242

Gardening Series | Flowers



By I. Shonle, L.G. Vickerman and J.E. Klett*

Why Grow Native Herbaceous Perennials?

There are many benefits to using Colorado native herbaceous perennials for home and commercial landscapes. They are naturally adapted to Colorado's climates, soils and environmental conditions. When they are correctly sited, they make ideal plants for a sustainable landscape. Native herbaceous perennials require less external inputs such as watering, fertilizing and other cultural factors when the planting site mimics the plant's native habitat.

Using Colorado natives in landscapes may attract a variety of wildlife including mammals, birds, butterflies and other native pollinators. Rapid urbanization in the state is reducing biodiversity (the number of different species found in a given area) as habitat is removed for building and road construction. Landscaping with natives on a large, or small, scale helps maintain biodiversity that otherwise would be lost to development.

The perennials listed in Table 1 were specifically chosen because they require low or moderate amounts of water. Not all perennials listed are available at all nurseries and garden centers, so it may be necessary to contact a number of commercial outlets to find a specific plant. If a perennial is not sold in the trade, asking for it may improve its future availability. Native perennials should not be collected from the wild because this reduces biodiversity, causes a disturbed area that may be invaded by weeds, and may be illegal. Transplanting a plant from the wild to the garden is rarely successful because of root damage and transplant shock.

*I. Shonle, Colorado State University Extension agent, Gilpin county; J. Klett, Extension landscape horticulture specialist and professor, department of horticulture and landscape architecture. L.G. Vickerman, former Extension agent, contributed to the first edition. 4/2014



Figure 1: *Callirhoe involucrata* (Purple poppy mallow).

Most of the perennials listed in Table 1 are available as container-grown plants. Native perennials often do not have as great a visual impact in the container or immediately after planting as do traditional horticultural species. Over time, however, they will reward the homeowner with their natural beauty.

Where to Grow Native Herbaceous Perennials

Due to Colorado's varying elevation and topography, native plants are found in a variety of habitats. To maximize survival with minimal external inputs, plants should be selected for your site's life zone and the plant's moisture, light and soil requirements. Even if a plant is listed for a particular life zone, the aspect (north, south, east or west facing) of the proposed site should match the moisture requirement. For example, a prairie zinnia, which requires full sun and has a very low moisture requirement, should not be sited with plants requiring higher moisture needs. Similarly, a prairie zinnia should not be planted on the north side of a building, where there is increased shade and moisture could severely affect its growth and appearance.

Growing native perennials does not exclude using adapted non-native plants. There are many non-native plants that are adapted to Colorado's climate and can

Quick Facts

- A Colorado native perennial is defined as a plant existing in Colorado prior to European settlement.
- Native plant gardens create wildlife habitat for a variety of birds, mammals and insects.
- Landscaping with native plants makes a significant contribution to biodiversity that otherwise would be lost to development.
- Native plant communities in Colorado vary due to differences in exposure, elevation, rainfall, soils and temperature extremes. These plant communities make Colorado visually distinct from other parts of the country.

© Colorado State University Extension. 3/04. Revised 4/14.

www.ext.colostate.edu





Figure 2: *Gaillardia aristata* (Blanket flower).



Figure 3: *Penstemon strictus* (Rocky Mountain penstemon).



Figure 4: *Tradescantia occidentalis* (Spiderwort).

be used in a native landscape as long as moisture, light and soil requirements are similar. Even if a site has a non-native landscape that requires additional inputs (such as an irrigated landscape on the plains), dry land native plants can be used in non-irrigated pockets within the non-native landscape. These native “pocket gardens” can be located in areas such as median strips and next to hardscapes that are difficult to irrigate. Note that in years with less than normal rainfall, non-irrigated landscapes may suffer in appearance.

Some communities regulate landscape appearance or the type of plants which may be used. Before initiating a landscape

design, check with local authorities, including homeowner’s associations, to discover any regulations that may affect the design.

Culture and Maintenance

There are three ways to establish a native herbaceous planting: 1) use nursery grown transplants, 2) direct seeding, or 3) using a combination of transplants and seeding. Successful establishment of native transplants requires supplemental moisture from a few months to several years after planting, but this can gradually be reduced. Seedlings benefit from supplemental watering until plants are established. Weed control prior to planting seed is critical for success. Nursery grown transplants are best planted in spring or early fall. Seeds can be planted from early to late spring or preferably in late fall.

Native plants can often be successfully grown in unamended soils. Most natives do not require nutrient rich, high organic content soil, and can often become overgrown or short lived in such soils. However, many native plants require well-drained soils. To amend clay soils, add 10 percent compost and 15 percent small aggregate (i.e., pea gravel) by volume to clay/clay loam and incorporate into the root zone. Creating a small berm and planting on the top can also be helpful to improve drainage. To amend excessively well-drained sandy or rocky soils, add 3 percent compost by volume.

A diverse planting of native herbaceous perennials can support a wide variety of wildlife throughout the season. Leave vegetation standing after the first hard frost to provide over-wintering sites for beneficial insects and birds.

Using native herbaceous perennials offers many benefits in addition to reduced maintenance. The need for fertilizers and pesticides can be greatly reduced or eliminated. Once established, native plantings can help conserve water. Our native plant communities make Colorado visually distinct from other parts of the country and will provide a better sense of place.



Figure 5: *Campanula rotundifolia* (Harebells).



Figure 6: *Monarda fistulosa* (Bee balm).



Figure 7: *Mirabilis multiflora* (Desert four o'clock).



Figure 8: *Zinnia grandiflora* (Prairie zinnia).

Table 1. Native herbaceous perennials for Colorado landscapes.

Scientific name ¹ Common name	Planting Elevation ²	Bloom time ³	Exposure	Moisture ⁴	Color	Height	Comments
<i>Allium cernuum</i> Nodding onion	To 10,000'	M	Sun to part shade	I-m	Pink	5-24"	Waxy foliage; nodding flowers from bulbs; attracts butterflies; well-drained soils.
<i>Amsonia jonesii</i> Blue star	To 7,000'	E-M	Sun	I	Blue	10-15"	Clusters of star-shaped flowers; foliage turns clear yellow in fall; Plant Select®.
<i>Anaphalis margaritacea</i> Pearly everlasting	To 10,500'	M	Sun	I-m	White	12-20"	Silvery foliage; button-like clusters on top of upright stems; excellent dried flower; most soils.
<i>Anemone multifida</i> Windflower	To 10,000'	E-M	Sun to part shade	I-m	White to pink-red	12-24"	Deeply cut dark green leaves form a rounded clump; flowers borne on wiry stems; organic soils.
<i>Antennaria parvifolia</i> and <i>A. rosea</i> Pussytoes	To 11,000'	E-M	Sun to part shade	I-m	Cream to pink	2-6"	Spreading mat of silver gray foliage; flowers in small clusters resemble cat toes; good between flagstones or in rock gardens; well-drained soils.
<i>Aquilegia caerulea</i> Blue columbine, Colorado Columbine	To 11,000'	E-M	Part shade	m	Blue/purple and white	12-36"	Delicate lobed leaves; large spurred flower; Colorado state flower; attracts hummingbirds; foliage often turns reddish in fall; organic soils.
<i>Aquilegia chrysantha</i> Golden columbine	To 11,000'	E-M	Sun to part shade	I-m	Yellow	24-36"	Robust plant with lobed leaves; many spurred flowers; attracts hummingbirds; reseeds readily; Plant Select®; clay or organic soils.
<i>Artemisia frigida</i> Fringed sage	To 10,000'	N/A	Sun	I	N/A	8-24"	Aromatic feathery silver foliage; evergreen; subshrub; insignificant bloom; well-drained soils.
<i>Artemisia ludoviciana</i> Prairie sage, Silver sage	To 10,000'	N/A	Sun	I	N/A	15-30"	Coarse silver foliage; insignificant bloom; aggressive grower; well-drained soils.
<i>Asclepias tuberosa</i> Butterfly weed	To 7,000'	M-L	Sun	I	Orange	18-36"	Umbrella-like clusters of flowers, narrow green leaves; attractive to butterflies; may be difficult to establish.
<i>Berlandiera lyrata</i> Chocolate flower, greeneyes	To 8,000'	M	Sun	I-m	Yellow with green/red centers	12-18"	Mounded rosette of lyre-shaped leaves; daisy like flowers with chocolate scent; thrives in heat; Plant Select®; well-drained soils.
<i>Callirhoe involucrata</i> Purple poppy mallow, Wine cups	To 7,000'	M-L	Sun	I-m	Magenta with white centers	4-10"	Spreading groundcover with scalloped leaves; long blooming; likes heat; Plant Select®; dry clay soils.
<i>Calylophus lavandulifolius</i> Sundrops	To 7,000'	M	Sun	I	Lemon yellow (spent flowers turn orange)	4-8"	Spreading habit; green narrow leaves; four-petaled flowers solitary on stems; long blooming; likes heat; well-drained soils.
<i>Calylophus serrulatus</i> Plains yellow primrose	To 7,000'	M	Sun	I	Yellow	15"	Mounding subshrub with narrow leaves; heavy bloomer; well-drained soils.
<i>Campanula rotundifolia</i> Harebells	To 13,000'	M-L	Sun to part shade	I-m	Purple	8-15"	Narrow delicate foliage; nodding bell shaped flowers; most soils.
<i>Clematis scottii</i> Scott's sugarbowl	To 8,500'	E	Sun to part shade	I-m	Purple	8-15"	Mounds of lacy foliage with nodding purple flowers; attractive to bumblebees; Plant Select Petite®
<i>Dalea purpurea</i> Purple prairie clover	To 7,500'	M	Sun	I	Purple	24-36"	Narrow leaflets; slender stems; cylindrical heads of fragrant flowers; fixes nitrogen; well-drained soils.



(Table 1, Continued)

Table 1. Native herbaceous perennials for Colorado landscapes.

Scientific name ¹ Common name	Planting Elevation ²	Bloom time ³	Exposure	Moisture ⁴	Color	Height	Comments
<i>Erigeron speciosus</i> Aspen daisy, Showy daisy	To 9,500'	M	Sun to part shade	l-m	Lavender blue with yellow center	12-18"	Rich green foliage; daisy-like flowers; attracts butterflies; most soils.
<i>Eriogonum umbellatum</i> Sulphur flower	To 10,500'	M	Sun	l	Sulphur yellow ages to rust brown	6-12"	Mat of leathery green foliage with silver undersides; turns reddish in fall; flowers attract butterflies; well-drained soils.
<i>Gaillardia aristata</i> Blanket flower	To 9,000'	M	Sun	l	Yellow (to yellow/red) with red/brown centers	18-24"	Fuzzy gray-green leaves; large daisy flowers; well-drained soils.
<i>Geranium viscosissimum</i> Sticky geranium	To 9,500'	E-M	Sun to part shade	l-m	Pale pink to rose/purple with darker veins	12-24"	Lobed leaves turn red in fall; open clusters of flowers with sticky stems; well-drained soils.
<i>Geum triflorum</i> Prairie smoke	To 10,000'	E	Sun to part shade	l-m	Cream to deep pink	6-12"	Rosettes of gray-green fernlike foliage; nodding flowers followed by long pink feathery seed heads; prefers moist clay or organic soils.
<i>Helianthus maximiliana</i> Maximilian sunflower	To 6,500'	L	Sun	l-m	Yellow	60-120"	Lance-shaped leaves on stout stems; showy flowers; spreads aggressively by rhizomes, esp. in moister soils; most soils.
<i>Heliomeris multiflora</i> Showy goldeneye	To 10,000'	L	Sun	l	Yellow	18-30"	Heavily branched with narrow leaves; prolific sunflower-like flowers; available only from seed; reseeds aggressively; well-drained soils.
<i>Ipomea leptophylla</i> Bush morning glory	To 7,000'	M-L	Sun	l	Lavender purple	24-36"	Spreading mounded plant with linear leaves; huge tap root; morning glory-like flowers; long lived; sandy or sandy loam soils.
<i>Ipomopsis aggregata</i> Scarlet gilia, Fairy trumpets	To 9,000'	M	Sun	l	Red, pink and white	12-30"	Rosette of finely divided leaves; trumpet-shaped flowers; attracts hummingbirds; biennial; reseeds readily; well-drained soils.
<i>Liatris punctata</i> Gayfeather, Blazing star	To 7,500'	L	Sun	l	Rose purple	12"	Rigid linear leaves; stout spikes of fringed flowers; attracts butterflies; well-drained soils.
<i>Linum lewisii</i> Blue flax	To 9,500'	Mid	Sun, part shade	l-m	blue	12-24"	Fine blue-green foliage; saucer-shaped flowers; reseeds readily; well-drained soils.
<i>Lupinus argenteus</i> Silver lupine	To 10,000'	M	Sun	l	White to deep purple	12-36"	Palm-shaped leaf; spikes of pea-like flowers; attracts butterflies; well-drained soils.
<i>Mondarda fistulosa</i> Bee balm, Wild bergamot	To 9,000'	M	Sun	l-m	Pink to lavender	12-36"	Upright growth with fragrant foliage; profuse wispy flowerheads; good air circulation will lessen powdery mildew; well-drained soils.
<i>Mirabilis multiflora</i> Desert four o'clock	To 8,000'	M-L	Sun, part shade	l	Pink to purple	12-30"	Blue-green leaves; wide spreading mounded habit; trumpet-shaped flowers with yellow stamens open late morning; well-drained soils.
<i>Oenothera caespitosa</i> White-tufted evening primrose	To 9,000'	M	Sun	l	White with pink buds	6-12"	Dense rosette of dark gray/green leaves; fragrant flowers open in late afternoon, fade the next morning; well-drained soils.
<i>Pulsatilla patens</i> Pasque flower	To 9,000'	E	Sun	l-m	Lavender	6-12"	Woolly foliage with cup-shaped flowers followed by feathery seed heads; well-drained soils.

(Table 1, Continued)

Table 1. Native herbaceous perennials for Colorado landscapes.

Scientific name ¹ Common name	Planting Elevation ²	Bloom time ³	Exposure	Moisture ⁴	Color	Height	Comments
<i>Penstemon ambiguus</i> Bush or sand penstemon	To 6,500'	M-L	Sun	l	Whitish pink	24-30"	Freely branching bushy plant with woody base; phlox-like flowers clustered towards top of stem; sandy soils.
<i>Penstemon angustifolius</i> Pagoda or narrow- leaved penstemon	To 7,500'	M	Sun	l	Sky blue	12"	Narrow blue-green foliage can be evergreen; numerous tubular flowers encircle stalks; requires well-drained soils.
<i>Penstemon barbatus</i> Scarlet bugler penstemon	To 9,000'	M	Sun	l	Scarlet to red	24-36"	Slender tall stalks with foliage clustered at base; tubular flowers favored by hummingbirds; well-drained soils.
<i>Penstemon caespitosus</i> Mat penstemon	To 9,000'	E-M	Sun	l	Blue to violet	4-6"	Mat forming with trailing stems; excellent for rock gardens; well-drained soils.
<i>Penstemon glaber</i> Smooth penstemon	To 9,000'	M	Sun	l	Deep blue/ purple	12-18"	Stout upright stems; tubular flowers; well-drained soils.
<i>Penstemon grandiflorus</i> Shell leaf penstemon	To 8,500'	M	Sun	l-m	White, pink, and purple	24-36"	Waxy blue-green semi-evergreen foliage; large tubular flowers; can be short lived but reseeds readily; well-drained soils.
<i>Penstemon mensarum</i> Grand Mesa penstemon	To 9,000'	M	Sun	l	Blue	24-30"	Stunning cobalt flowers on narrow spikes; evergreen leaves; Plant Select®.
<i>Penstemon secundiflorus</i> Orchid/Sidebells penstemon	To 9,500'	M	Sun	l-m	Pink/purple	6-18"	Waxy blue-green foliage; tubular flowers emerge from one side of the stalk; rocky soils.
<i>Penstemon strictus</i> Rocky Mountain Penstemon	To 10,000'	M	Sun to part shade	l-m	Blue to blue- purple	12-30"	Robust grower; narrow glossy green leaves; tubular flowers in open spikes; develops powdery mildew if crowded; well-drained soils.
<i>Penstemon virens</i> Bluemist penstemon	To 10,000'	E-M	Sun to part shade	l-m	Light blue to blue/violet	6-12"	Dense basal rosette of bright green leaves; profuse clusters of small flowers; good for rock gardens; rocky soils.
<i>Penstemon virgatus</i> Wand bloom penstemon	To 10,000'	M	Sun	l-m	Pale blue to violet	12-30"	Erect slender stalks; linear upright leaves; tubular flowers; well-drained soils.
<i>Penstemon whippleanus</i> Whipple's penstemon	To 12,000'	M	Sun to part shade	l-m	Wine purple or white	10-20"	Clustered stems; whorls of nodding tubular flowers; adaptable to moister soils.
<i>Polemonium caeruleum</i> Jacob's ladder	To 9,000'	M	Part shade	m	Blue-purple	18-24"	Clusters of bell-shaped flowers on upright plants; small pinnately compound leaves.
<i>Ratibida columnifera</i> Prairie coneflower, Mexican hat	To 7,500'	M-L	Sun	l	Yellow	12-24"	Upright slender stalks; finely divided leaves; prominent central cone surrounded by drooping petals; short-lived but reseeds; well-drained soils.
<i>Rudbeckia hirta</i> Black-eyed Susan	To 9,000'	M	Sun to part shade	m	Yellow with brown to black center	12-24"	Fuzzy green leaves with daisy-like flowers; biennial to short lived perennial; reseeds; most soils.
<i>Solidago canadensis</i> Goldenrod	To 7,000'	M	Sun to part shade	l-m	Yellow	12-36"	Upright stems; spreads by underground rhizomes; spikes of flowers; attracts butterflies and bees; mistakenly blamed as cause of hayfever; clay or loam soils.



(Table 1, Continued)

Table 1. Native herbaceous perennials for Colorado landscapes.

Scientific name ¹ Common name	Planting Elevation ²	Bloom time ³	Exposure	Moisture ⁴	Color	Height	Comments
<i>Sphaeralcea coccinea</i> Scarlet globemallow	To 8,000'	E-M	Sun	l	Coral red, orange	8-12"	Hairy gray-green leaves; vigorous rhizomes; small hollyhock-like flower; well-drained coarse soils.
<i>Stanleya pinnata</i> Prince's plume	To 9,000'	M	Sun	l	Yellow	24-48"	Gray-green leaves; large plume-shaped flower spikes; can be short lived; well drained soils.
<i>Thelesperma filifolium</i> Navajo tea, Greenthread	To 8,000'	M-L	Sun	l-m	Yellow	16-24"	Vase-shaped clump; finely dissected leaves; profuse daisy- like flowers over long period; well-drained soils.
<i>Thermopsis divaricarpa</i> Golden banner	To 11,000'	E-M	Sun to part shade	l-m	Yellow	18-24"	Spreads vigorously by rhizomes; needs room; showy spikes of pea-like flowers; well-drained soils.
<i>Tradescantia occidentalis</i> Spiderwort	To 8,000'	M	Sun to part shade	l-m	Purple/blue	12-24"	Upright stalks above grass-like foliage; clusters of three petaled flowers each lasting a day; most soils.
<i>Verbena bipinnatifida</i> Spreading vervain	To 8,000'	E-L	Sun	l	Rose/purple	6-10"	Spreading stems with deeply cut leaves; prolific bloomer; attracts butterflies; well-drained soils.
<i>Zinnia grandiflora</i> Prairie zinnia, Golden paperflower	To 6,000'	M-L	Sun	l	Yellow	6-8"	Mounding habit with wispy leaves; prolific bloomer; flowers have a papery texture; requires well-drained soils.

¹As commonly sold in the trade. For equivalents, see botanical publications.

²Planting elevations are estimates of where plants may be successfully grown as landscape plants. In many cases, species may be successfully planted at a lower elevation with supplemental irrigation or at higher elevations with protection.

³Bloom time E=Early (March through end of May); M=Mid (June through Mid-August); L=Late (Mid-August through frost).

⁴Moisture requirement l=Low; m=Moderate.

Plant Select[®] is a program that seeks and distributes information about the best plants for gardens from the high plains to the intermountain region. It is a cooperative program administered by the Denver Botanic Gardens and Colorado State University Extension, together with landscape and nursery professionals throughout the Rocky Mountain region and beyond.

Colorado State University, U.S. Department of Agriculture and Colorado counties cooperating. CSU Extension programs are available to all without discrimination. No endorsement of products mentioned is intended nor is criticism implied of products not mentioned.

This page intentionally left blank.



This page intentionally left blank.



Native Trees for Colorado Landscapes

Fact Sheet No. 7.421

Gardening Series | Trees and Shrubs

by J. Klett, B. Fahey, R. Cox and I. Shonle*

Why Grow Native Trees?

There are many benefits to using Colorado native trees for home and commercial landscapes. Colorado native trees are naturally adapted to their specific Colorado climate, soil, and environmental conditions. When correctly sited, they can be ideal plants for a sustainable landscape that requires reduced external inputs such as watering, fertilizing, and pruning. In order to realize these benefits, the planting site must approximate the natural environmental conditions of the plant in its native habitat.

Another benefit of using Colorado native trees in landscapes is that they attract a wide variety of wildlife including mammals, birds, and butterflies. Rapid urbanization in the state is reducing biodiversity as habitat is removed for building and road construction. Landscaping with natives on a large or small scale can maintain biodiversity that otherwise could be lost to development.

The trees listed in Table 1 are grown by some Colorado nurseries and are becoming more available in the commercial sector. However, not all trees listed are available at all nurseries, so you may need to contact several commercial outlets to find a specific plant. If a tree is not sold in the trade, asking for it may help increase its availability. Native trees should not be collected from the wild because this reduces the biodiversity and causes a disturbed area that may be invaded by weeds.

Most of the trees listed in Table 1 are available as container-grown plants. Native trees often do not have as great a visual impact in the container or immediately after planting as do traditional horticultural

species. Over time, they reward the homeowner with their natural beauty and other benefits.

Where to Grow Native Trees

There are several factors to consider when designing a native landscape. Due to Colorado's variation of elevation and topography, native plants are found in many habitats. In order to maximize survival with minimal external inputs, trees should be selected to match the site's life zone and the plant's moisture, light, and soil requirements. Even if a plant is listed for a particular life zone, the aspect (north, south, east, or west facing) of the proposed site should match the moisture requirement. For example, a Colorado blue spruce, which has a high moisture requirement, should



Figure 1: Ponderosa pine cones (*Pinus ponderosa*)



Figure 2: Alder fruit (*Ainus tenuifolia*)

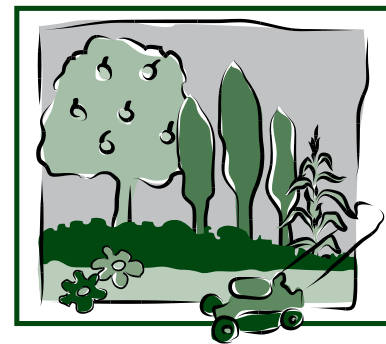

Quick Facts

- A Colorado native tree can be described as existing in Colorado prior to European settlement.
- Native plant communities make Colorado visually distinct from the eastern, southern or western United States.
- Native plant gardens are wildlife habitats and each plant contributes to the biodiversity of the state.
- Landscaping with natives on a large or small scale can maintain biodiversity that otherwise would be lost to development.

© Colorado State University
Extension. 6/02. Revised 1/18.
extension.colostate.edu



*J. Klett, Colorado State University Extension landscape and horticulture specialist; B. Fahey, Jefferson County Extension natural resources/horticulture agent; R. Cox, Arapahoe County Extension horticulture agent., retired, and I. Shonle, Gilpin County Extension Director/Agent.





Figure 3: Ponderosa pine (*Pinus ponderosa*)



Figure 4: Bristlecone pine (*Pinus aristata*)



Figure 5: Douglas-fir cone (*Pseudotsuga menziesii*)

not be sited with plants of dissimilar water needs. Similarly, a Colorado blue spruce should not be planted on a south-facing slope, where a significant amount of additional moisture would be required.

Growing native trees does not exclude the use of adapted non-native plants. There are many non-native plants that are adapted to Colorado's climate and can be used in a native landscape as long as moisture, light, and soil requirements are similar. If a site has a non-native landscape that requires additional inputs (such as an irrigated landscape on the plains), dry land native plants can be used in non-irrigated pockets within the non-native landscape. These native "pocket gardens" can be located in areas such as parkways and next to hardscapes that are difficult to irrigate.

Some communities regulate landscape appearance or the type of plants that may be used. So before completing a landscape design, check with local authorities, including homeowner's associations, to discover any regulations that may affect your design.

Life Zones of Colorado

Colorado can be divided into five life zones that are broadly defined by the plant communities that occur at the approximate elevations described below. The Plains life zone, 3,500 to 5,500 feet, is located in eastern Colorado where the majority of Colorado's population resides. It is dominated by grasslands and streamside cottonwoods. In western Colorado, the Upper Sonoran life zone is located at altitudes below 7,000 feet, and in the San Luis Valley, below 8,000 feet. This zone is characterized by semi desert shrublands and piñon pine-juniper woodlands at its upper limit.

The Foothills life zone occurs from 5,500 to 8,000 feet and is dominated by dry land shrubs such as Gambel oak and mountain-mahogany, and in southern and western Colorado, piñon-juniper woodlands and sagebrush. The Montane zone consists of ponderosa pine, Douglas-fir, lodgepole pine, and aspen woodlands at elevations of 8,000 to 9,500 feet. Dense forests of subalpine fir and Engelmann spruce dominate the Subalpine zone at 9,500 to 11,500 feet. The Alpine zone above 11,500 feet is a treeless zone made up of grasslands called tundra. Species



Figure 6: Douglas-fir (*Pseudotsuga menziesii*)



Figure 7: Gambel oak (*Quercus gambelii*)

requiring medium to high moisture occur along watercourses throughout all zones.

Culture and Maintenance

Successful establishment of native trees may require supplemental moisture after planting. Once established, the watering frequency can be reduced or eliminated, if the plant was sited in its native environmental conditions. Container-grown trees can be planted at any time during the growing season. Container-grown native trees are often grown in a soilless mixture of peat and bark, so the planting site should be amended with some organic material. Another option would be to carefully wash off the media from the container grown plant and plant it bare root.

Using native trees offers many benefits in addition to reduced maintenance. Natives are part of our natural heritage and the ecosystems of Colorado. Native plant communities make Colorado visually distinct from the eastern, southern, or western United States. Native plant gardens are wildlife habitats and each plant contributes to the biodiversity of the state.

Table 1. Native trees for Colorado landscapes.

Scientific Name ¹	Common Name(s)	Planting Altitude in feet ²	Native Colorado Life Zone ³	Moisture ⁴	Evergreen/Deciduous	Comments ⁵
Large trees (45+ ft when mature)						
<i>Abies concolor</i>	white fir, concolor fir	4,000 - 10,000	Foothills - Montane	M - H	E	Symmetrical, pyramidal shape; for large landscapes; attractive, soft, blue-green needles; grows best where protected from wind.
<i>Abies lasiocarpa arizonica</i>	corkbark fir, subalpine fir	7,000 - 11,000	Montane - Subalpine	M - H	E	Narrow, pyramidal habit; blue-green needles; corky, white bark; less commonly available; potential for use at lower elevations.
<i>Acer negundo</i>	boxelder	4,500 - 7,500	Plains - Foothills, Upper Sonoran	M - H	D	Maple with compound leaves; found along streams; rapid grower; weak-wooded; short-lived; female trees attract nuisance boxelder bugs.
<i>Picea engelmannii</i>	Engelmann spruce	5,000 - 11,000	Montane - Subalpine	M - H	E	Large, densely pyramidal tree with blue-green needles and reddish, scaly bark when mature; found at high elevations with subalpine fir where it performs best; less commonly available.
<i>Picea pungens</i>	Colorado spruce	4,000 - 9,500	Foothills - Montane	M - H	E	Colorado state tree; sharp, stiff needles ranging from green to silvery-blue; horizontal branching.
<i>Pinus contorta latifolia</i>	lodgepole pine	6,000 - 11,000	Montane - Subalpine	M	E	Light green needles; persistent cones; tall, narrow form in native habitat; broader habit in landscape site; requires well-drained soils.
<i>Pinus flexilis</i>	limber pine	4,000 - 10,000	Montane - Subalpine	L - M	E	Green to blue-green needles in bundles of 4-5; flexible twigs; larger, ornamental cones.
<i>Pinus ponderosa</i>	ponderosa pine	4,000 - 9,000	Foothills - Montane	L - M	E	Longer, yellow-green needles; bark has vanilla fragrance on warm days; turns cinnamon color with age.
<i>Pinus strobiformis</i>	Southwestern white pine	4,000 - 8,500	Foothills - Montane	L - M	E	Blue-green needles; large cones; scaly bark when mature; faster-growing; less commonly available.
<i>Populus angustifolia</i>	narrowleaf cottonwood	4,000 - 9,500	Foothills - Montane	H	D	Vertical growth habit; willow-like leaves; suckers heavily; best in natural areas along streams; males do not produce cotton; yellow fall color.
<i>Populus sargentii</i>	Plains cottonwood	4,000 - 7,000	Plains - Foothills, Upper Sonoran	H	D	Fast-growing; broad, irregular canopy; triangular leaves; males do not produce cotton.
<i>Populus x acuminata</i>	lanceleaf cottonwood	4,500 - 8,500	Foothills	H	D	Fast-growing; upright, rounded, dense branching; spear-shaped, drooping leaves; less suckering; natural hybrid between Plains and narrowleaf cottonwoods; males do not produce cotton.
<i>Pseudotsuga menziesii</i>	Douglas-fir	4,500 - 11,000	Foothills - Montane	M	E	Fast-growing; soft, medium to dark green needles; pyramidal shape; unique cones; alternate host for gall insects on spruce.
Small - Medium Trees (10 - 45 ft when mature)						
<i>Acer grandidentatum</i>	bigtooth maple, Wasatch maple	4,500 - 7,000	Foothills - Montane ^{3a}	L - M	D	Native to southwest, with occurrences in Montezuma County; often multi-stem form; degree of orange-red fall color varies.
<i>Alnus tenuifolia</i>	thinleaf alder	5,000 - 10,000	Foothills - Subalpine	H	D	Large shrub or small tree; often multi-stemmed; yellow fall color not reliable; persistent fruits resemble miniature pine cones; found along streams; gray bark; sun to part shade.
<i>Betula occidentalis (Betula fontinalis)</i>	Western water birch, Rocky Mountain birch		5,000 - 9,000	Foothills - Montane	H D	Small tree or large shrub; bronze-red bark; found along streams, often with thinleaf alder; yellow fall color; requires additional moisture in dry winters.
<i>Juniperus monosperma</i>	oneseed juniper	4,000 - 7,500	Plains - Foothills ^{3b}	L	E	Multi-stemmed tree with small, scale-like leaves; found on dry rocky slopes, often with piñon.
<i>Juniperus osteosperma</i>	Utah juniper	5,000 - 9,000	Upper Sonoran - Foothills ^{3a}	L	E	Spreading, multi-stemmed tree with small, scale-like leaves; large, grayish-blue, berry-like fruits are important food for small mammals and birds.



Table 1 (cont.). Native trees for Colorado landscapes.

Scientific Name ¹	Common Name(s)	Planting Altitude in feet ²	Native Colorado Life Zone ³	Moisture ⁴	Evergreen/Deciduous	Comments ⁵
Small - Medium Trees (10 - 45 ft when mature)						
<i>Juniperus scopulorum</i>	Rocky Mountain juniper	4,000 - 8,000	Foothills - Montane	L	E	Variable growth habit, often upright to columnar; male and female flowers on separate plants; found on dry mountain slopes and mesas; berry-like fruits are important food for small mammals and birds.
<i>Pinus aristata</i>	bristlecone pine	5,000 - 11,000	Montane - Subalpine	L - M	E	Rounded to pyramidal shape; branches have bottlebrush appearance; short, dark green needles with specks of white resin; spiny cones; needs well-drained soil; slow-growing.
<i>Pinus edulis</i>	piñon, pinyon pine	4,000 - 7,500	Foothills - Montane, Upper Sonoran	L	E	Compact, bushy tree with grayish-green needles in bundles of two; small rounded cones; edible seeds develop when planted in grove for cross-pollination; best in dry, well-drained site.
<i>Populus tremuloides</i>	quaking aspen	4,000 - 10,000	Foothills - Subalpine	H	D	Leaves flutter in slight breeze; short-lived, suckers; best in well-drained mountain soils.
<i>Quercus gambelii</i>	Gambel oak, scrub oak	4,000 - 8,500	Foothills - Montane	L - M	D	Shades of red, orange, yellow, and brown in fall; acorns provide excellent wildlife food.
<i>Salix amygdaloides</i>	peachleaf willow	3,500 - 7,000	Plains - Foothills, Upper Sonoran	H	D	Fast-growing; lance-shaped leaves; new twig growth orange-yellow; ascending branches; found along streams.

¹ As commonly sold in the trade. For equivalents, see botanical publications.

² Planting altitudes are estimates of where plants may be successfully grown as landscape plants. In many cases, species may be successfully planted at a lower zone with supplemental irrigation or a higher zone with protection.

³ Approximate life zone elevations: Plains - below 5,500 ft. in eastern CO; Upper Sonoran - below 7,000 ft. in western CO and below 8,000 ft. in San Luis Valley; Foothills - 5,500 - 8,000 ft.; Montane - 8,000 - 9,500 ft.; Subalpine - 9,500 - 11,500 ft.; Alpine - above 11,500 ft. Species requiring medium to high moisture occur along watercourses throughout all zones. For simplicity, life zones were taken from *Grassland to Glacier* by Mutel and Emerick, first edition, 1984. For a more detailed treatment of Colorado ecosystems, see second edition, 1992.

^{3a} Native to Western Slope; ^{3b} Native to Eastern Slope

⁴ Moisture Requirement: L - Low, M - Moderate, H - High

⁵ Except where noted, plants prefer full sun.

Colorado State University, U.S. Department of Agriculture and Colorado counties cooperating. CSU Extension programs are available to all without discrimination. No endorsement of products mentioned is intended nor is criticism implied of products not mentioned.

This page intentionally left blank.



This page intentionally left blank.

Low-Water Native Plants for Colorado Gardens: *Front Range & Foothills*

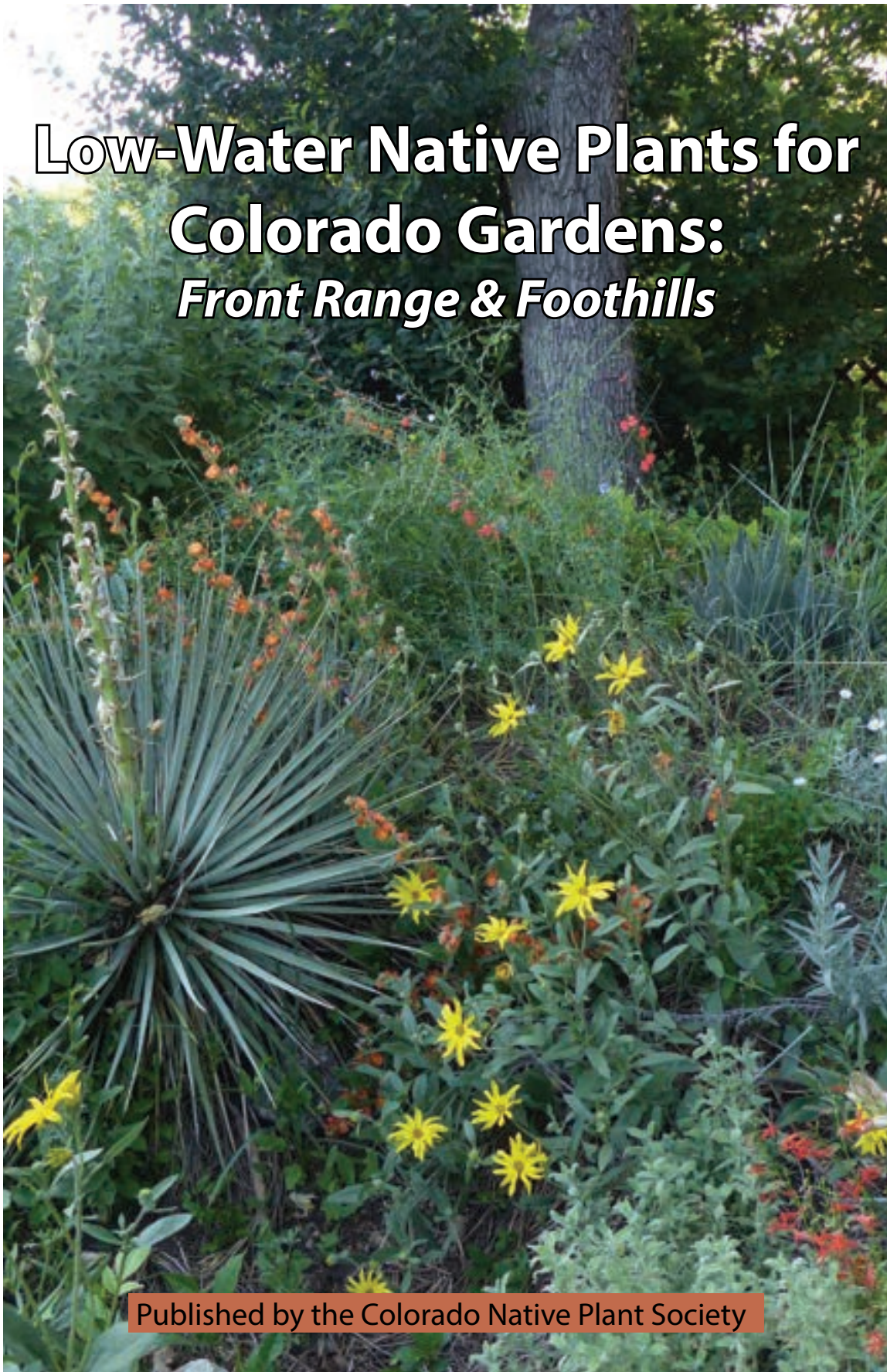

Published by the Colorado Native Plant Society



BLOOM

Front Range and Foothills Region



This range map is approximate. Please be familiar with your area to know which booklet is most appropriate for your landscape.

The Colorado native plant gardening guides cover these 5 regions:

Plains/Prairie

Front Range/Foothills

Southeastern Colorado

Mountains above 7,500 feet

Lower Elevation Western Slope

This publication was written by the Colorado Native Plant Society Gardening Guide Committee: Irene Shonle, Director, CSU Extension, Gilpin County; Nick Daniel, Horticulturist, Denver Botanic Gardens; Deryn Davidson, Horticulture Agent, CSU Extension, Boulder County; Susan Crick, Front Range Chapter, Wild Ones; Jim Tolstrup, Executive Director, High Plains Environmental Center (HPEC); Jan Loechell Turner, Colorado Native Plant Society (CoNPS); Amy Yarger, Director of Horticulture, Butterfly Pavilion. Scientific names are from the *Flora of North America*.

Photo credits: Gardening Guide Committee members, LBJ or otherwise listed.
Map: U.S. Census Bureau, Census 2000

Front Cover: Turner yard, Photo by Jan L Turner Back Cover: Scarlet Glabemallow, Photo by Rick Brune.



Garden at the Schultz Residence in Fort Collins. Colors and textures create an eye-catching combination in the Schultz's garden. In the left foreground, the purple flowers of desert four o'clock (*Mirabilis multiflora*) are abundant and beautiful, opening in the afternoon. Each plant can spread to cover a large area (4' x 4') and can drape over terraces. Showy orange butterfly milkweed (*Asclepias tuberosa*) attracts a collection of bees and butterflies (and humans!) and can serve as a host plant for larvae of Monarch butterflies. The soft, blue-grey leaves of Prairie sage (*Artemisia ludoviciana*) form the perfect backdrop for the butterfly milkweed. Photo by Jim Tolstrup.

Introduction

This is one in a series of regional native planting guides that are a collaboration of the Colorado Native Plant Society, CSU Extension Native Plant Master® Program, Front Range Wild Ones, the High Plains Environmental Center, Butterfly Pavilion and the Denver Botanic Gardens.

Many people have an interest in landscaping with native plants, and the purpose of this booklet is to help people make the most successful choices. We have divided the state into 5 different regions that reflect different growing conditions and life zones. These are: the plains/prairie, southeastern Colorado, the Front Range/foothills, the mountains above 7,500', and lower elevation Western Slope. Find the area that most closely resembles your proposed garden site for the best gardening recommendations.



Why Native?

There are many benefits to using Colorado native plants for home and commercial landscapes. They are naturally adapted to Colorado's climates, soils and environmental conditions. This means that by choosing native plants gardeners can work with nature, rather than trying to grow plants that are not suited to our local conditions and may prove to be difficult to work with.

When correctly sited, natives make ideal plants for a sustainable landscape. Native species require less external inputs such as water and fertilizer, and are more resistant to pests and disease when the planting site mimics the plant's native habitat. Landscape water use accounts for about 55 percent of the residential water used across the state of Colorado, most of which is used on turf. Planting less-thirsty natives has the potential to lessen the burden on our water systems.

Another great reason to go native is to restore habitat. Rapid urbanization in the state is reducing biodiversity (the number of different species found in a given area) as habitat is removed for building and road construction. Research has shown that landscaping with natives on a large, or small scale, helps maintain biodiversity that otherwise would be lost to development. Thousands or millions of gardens planted with natives, even in urban areas can add food, shelter and other important resources for wildlife, including mammals, birds and native pollinators.

Growing native plants does not exclude using adapted non-native plants. There are many non-native plants that are adapted to Colorado's climate and can be used in a native landscape as long as moisture, light and soil requirements are similar. Even if a site has a non-native landscape that requires additional inputs (such as an irrigated landscape on the plains), dry-land native plants can be used in non-irrigated pockets within the non-native landscape. These native "pocket gardens" can be located in areas such as median strips and next to hardscapes that are difficult to irrigate. Note that in years with less than normal rainfall, non-irrigated landscapes may suffer in appearance without supplemental water.

Gardening with native plants also prevents the introduction and spread of noxious weeds. Many noxious weeds were intentionally introduced as garden plants that belatedly were found to escape the confines of the garden and crowd out native plants.

Some communities regulate landscape appearance or the type of plants which may be used. Before initiating any new landscape design, check with local municipalities and/or homeowners' associations, to discover any regulations that may affect your design.



The Turner's yard: A berm with native plants is interesting and colorful. Plains yucca (*Yucca glauca*) on the right is in bloom. Behind the yuccas, higher on the berm are tall blooming stalks of orange littleleaf globemallow (*Sphaeralcea parviflora*). In the lower left is blue flax, that will shed its petals in the afternoon, harebells, and chimingbells (*Mertensia lanceolata*). The bright yellow flowers of little sunflower (*Helianthus pumilis*) are in front of the yucca. Photo by Jan Turner.

Finally, using native plants in landscapes helps provide a special sense of place, celebrating Colorado's uniqueness and beauty, rather than a generic landscape. A garden with native plants feels more harmonious with its surroundings, than a landscape transplanted from another locale.

Native Plant Gardening in Colorado's Front Range and Foothills

The Front Range and foothills region of Colorado is the area east of the Continental Divide and west of the prairies and plains (see map). It is an area with a high diversity of plant life and growing conditions. Running north-south, it includes the cities of Fort Collins, Greeley, Loveland, Longmont, Boulder, Golden, Denver and its suburbs. Castle



Rock, Colorado Springs, Pueblo and Cañon City will be included in the Southeastern Colorado guide.

The Front Range and foothills include everything from forests and rocky hillsides, to riverbeds, marsh wetlands and short grass prairie. With the wide range of growing conditions and native plants available, depending on where you live, you may be able to represent several vegetative communities within your garden successfully.

The proximity to the Rocky Mountains gives the Front Range and foothills a complex climate. This area can experience high winds, localized heavy rains, high snowfall and/or long periods of drought. It receives less precipitation than the mountains to the west and maintains relatively low humidity.

Soils range from well-drained and rocky with little organic matter, to sticky, heavy clay. It is important to determine what type of soil you have before you begin selecting plants.

There is a great deal of wildlife within this area. Even urban and suburban areas can be home for a variety of songbirds, bees and butterflies. Gardeners in these areas may have to take measures to repel rabbits or squirrels. Areas closer to the foothills may have to protect their plantings from deer or elk.

Culture and Maintenance

Soils

Colorado soils, on average, are fairly low in organic matter and high in pH (alkaline). The good news is that native plants usually can be successfully grown in unamended soils. This is because natives do not require nutrient rich, high organic content soil, and can often become overgrown or short lived in such soils. Many native plants, especially those from prairies or the Front Range, will thrive in clay soils. However, some native plants require well-drained soils. To amend clay soils, add 10 percent compost and 15 percent small aggregate (i.e., pea gravel) by volume to clay/clay loam and incorporate into the root zone. Creating a small berm and planting on the top can also be helpful to improve drainage. To amend excessively well-drained sandy or rocky soils, add 3 percent compost by volume. It may be beneficial to test the soil before planting, especially on a larger project. Soil testing kits are available at your local CSU Extension office.

Maintenance

Native plants often do not need much maintenance; just the usual pruning of dead or diseased material, and cutting back perennials in the spring. Leaving seed heads on the plants in the fall will not only provide a feast for birds, and protect caterpillar eggs and chrysalises, but will increase plant hardiness and winter interest. Native plants typically do not require fertilizer. Some tasks, such as weeding and deadheading, require the same time investment for native plant gardens as for gardens with non-natives.

Watering

Plants will need to be watered for at least the first season, with the most critical time being the first three weeks after planting. Once they are established, water can be cut back gradually. After establishment, some natives can be taken off irrigation completely. Place plants that have higher water needs nearer the house or other highly used areas. These plants can also be planted in swales (lower areas), or near downspouts for passive water harvesting.

Limiting/reclaiming turf areas

Although grass lawns are popular, they generally use more resources like water, fertilizers, pesticides, and maintenance (mowing) than a landscape of native plants. Lawns also provide no habitat for pollinators and birds. Native landscapes, on the other hand, are less resource intensive, provide habitat and provide more interest and color. Consider either limiting grass lawns to play, pet, or entertaining areas, or replacing lawns altogether if these spaces are not needed.

To reclaim a space formerly devoted to a lawn, spend some time eradicating all grasses and weeds. Grass is easier to kill when it is green and actively growing in the spring or fall. There are a few options for this. One is to use a glyphosate-based herbicide, another is to cut out all the sod, and a third is to solarize the area. Solarization works best in the heat of the summer in full-sun areas.



This lawn is being smothered by layers of newspapers covered with several inches of mulch (created from a dead tree that was ground up). Photo by Jan Turner



Mow the area and remove the clippings, water, place clear plastic on top (burying the edges with soil) and leave it for 4-6 weeks. A final option is to sheet mulch. Cover the area with sheets of cardboard or 12 layers of newspapers. Overlap these materials at least 6 inches so no light penetrates and wet them down to keep them in place. Place 1 inch of compost on top of the barrier layer. Add at least 6 inches more of mulch or compost (grass clippings, straw or leaves) and leave 4-6 weeks. Make sure that all of the grass is smothered because any grass that remains will be difficult to remove if it grows around your new plants.

Wildlife and Pollinators

Providing habitat for songbirds and pollinators is one of the great pleasures of gardening with native plants. To maximize habitat for pollinators, plant a diversity of plants, and aim to provide the longest possible season of bloom.



Butterfly on Rocky Mountain bee plant (*Cleome serrulata*). Photo by Jan Turner.

Many plants will provide nectar for adult insects, but consider the larval stage in planting too. Most native insects have specialized relationships with native plants, and require specific plants to grow from egg to adult. As an example, many butterflies will sip nectar from non-natives, but the eggs need to be laid on specific plants or the caterpillars won't recognize the plant as food. Purchase pesticide-free plants. There

has been recent concern that neonicotinoids are harmful to bees, so look for neonic-free plants.

Birds use native plants for food and shelter, but insects are an overlooked and crucial part of many bird's diets. Far more insects will develop on native plants than exotics, providing food for birds during the critical nesting season. Consider planting a 'thicket' of berry-producing shrubs. If planted in the direction of the prevailing wind, this thicket can also provide a space of calm air for butterflies.

Inventory Your Yard & Microclimates

For the best garden, spend some time in the planning stage. Identify where you would like to create a new bed, or replant an existing one. Inventory the areas in your yard for sun and shade, and for areas where moisture accumulates. Consider what areas have easiest access from the house, and if there are views you would like to enhance or block. All of these factors create what are known as *microclimates* or small, but potentially significant changes in the immediate environment that will affect your plants. Knowing these ahead of time will help you make the most of your site and can guide your plant choices.



Despite its name, swamp milkweed (*Asclepias incarnata*) does well in dry spots in Jim and Dorothy Borland's yard. The beautiful heads of rose and whitish flowers attract pollinators including Monarchs and other butterflies. It is worth using a hand lens to look at the flower structure.
Photo by Jim Borland.

Design for Low Maintenance

Native plants can be used to accomplish just about any design style you're looking for using the elements and principles of good design: color, texture, balance, unity, variety, rhythm, line, form, scale. They can be used for anything from formal designs to, the more informal, naturalistic plantings that most people think of when they think native.

Choose species based on the soil, light and water conditions of your site and for the size, shape, texture, and color desired. For a more natural, successful and easily maintained landscape, group species that grow together naturally and have the same cultural requirements. This will improve plant health and appearance and will minimize maintenance.

South-facing areas with reflected heat will do best with dryland or desert plants. North-facing areas are cooler, moister and shadier, and will do better with forest-edge type plants. West-facing areas are more similar to south-facing, even if they only get a half day of sun, so this



is a good spot for dryland, prairie, or chaparral plants. The east-facing side is usually the most benign, and can grow a wide variety of plants.

Plants that have higher water needs should be placed near the house for easier watering, or near downspouts or in low-lying areas where they will get extra water.

Be vigilant with weeding, especially in the first few years of planting so they don't take over the desirable vegetation. Plant thickly enough that the plants become a living mulch.

Suggested Reading

**Items available from the CoNPS Store at the time this booklet was published are marked with an asterisk. Others may be out-of-print and can be obtained from Amazon or the public library.*

Brune*, Rick. 1991. *The Prairie Garden*. Colorado Native Plant Society.

Busco*, Janice and Nancy Morin. 2010. *Native Plants for High Elevation Western Gardens*. Fulcrum Publishing.

Dorn*, Robert and Jane Dorn. 2007. *Growing Native Plants of the Rocky Mountain Area*. Lulu.

Ellefson, Connie and David Winger. 2013. *Xeriscape Colorado*. Westcliffe.

"Gardening with Native Plants." 2016. Colorado Native Plant Society.

<https://conps.org/gardening-with-native-plants/>

Hayes*, Rhona Fleming. 2015. *Pollinator Friendly Gardening: Gardening for Bees, Butterflies and Other Pollinators*. Voyageur Press.

Nold, Robert. 2008. *High and Dry: Gardening with Cold-Hardy Dryland Plants*. Timber Press.

"Plant Materials for Pollinators and Other Beneficial Insects in Eastern Utah and Western Colorado." http://efotg.sc.egov.usda.gov/references/public/CO/COPMTN_75_130711_comp.pdf

Tallamy*, Douglas. 2009. *Bringing Nature Home*. Timber Press.

Xerces Society*. 2011. *Attracting Native Pollinators*. Storey

Plant List

The plants for each of these guides were selected by experienced gardeners, with further input from members of the Colorado Native Plant Society. We aimed to choose plants that would be relatively easy to find in nurseries and seed catalogs. The scientific names are from Jennifer Ackerfield's *Flora of Colorado* (Britt Press, 2015); synonyms are in parentheses. For a listing of nurseries and seed companies that carry native plants, look for the "Native Plant Vendors" list on the Colorado Native Plant Society (CoNPS) website at <http://conps.org/gardening->

with-native-plants/ or consider attending the native plant sales held by CoNPS. When you go to a nursery, be sure to have the scientific name with you to make sure you are purchasing the correct species. Don't forget to ask for pesticide-free plants so pollinators won't be harmed.

Colorado Native Plant Society Mission Statement

The Colorado Native Plant Society is dedicated to furthering the knowledge, appreciation and conservation of native plants and habitats of Colorado through education, stewardship and advocacy.

Visit CoNPS website at <http://www.conps.org>



Key to Chart

The chart on the following pages contains a list of plants, *listed alphabetically by scientific name (column 2 of the chart)*, that are native to Colorado and do well in Front Range gardens. The scientific names are from *Flora of Colorado* by Jennifer Ackerfield. An asterisk indicates that the plant occurs naturally in the southern-most part of the Front Range but will also do well in gardens in the Metro-Denver area. Not all plants illustrated in this guide are listed in the chart, but the scientific names are given so you can find them in a nursery. If you have questions, contact CoNPS or one of the other organizations that collaborated to produce this guide.

frt/birds,wl = fruit for birds and wildlife

hp = host plant

hp/hm = host plant for hawk moth

np/bee,btf = nectar and pollen for bees and butterflies

np/bee,btf,o = nectar and pollen for bees, butterflies, and other pollinators

n/hb = nectar for hummingbirds

n/hm=nectar for hawkmoths

p/bees = pollen for bees

ss/birds = seeds and shelter for birds

s/birds = seeds for birds

Bloom Time:

spring = SP

summer = S

fall = F



Common Name	Scientific Name	Mature Size	Water	Exposure	Flower Color	Bloom Time	Wildlife Value
GROUNDCOVERS							
Pussytoes (perennial)	<i>Antennaria parvifolia</i>	2" x 6"	low-med	sun/part shade	cream/pink	SP-S	np/bee, btf
Wine Cups (perennial)	<i>Callirhoe involucrata</i>	4"x10"	low-med	sun	magenta	SP-S	np/bee, btf
Spreading Daisy (perennial)	<i>Erigeron divergens</i>	2" x 16"	low	sun	white	SP-S	np/bee, btf
Sulphur Flower (perennial)	<i>Eriogonum umbellatum</i>	10" x 12"	low	sun/part shade	yellow	S	np/btfl
Creeping Mahonia (shrub)	<i>Berberis repens (Mahonia repens)</i>	12" x 12"	med.	sun/part shade	yellow	SP	np/bee, btf
Gro-Low Fragrant Sumac (shrub)	<i>Rhus trilobata 'Gro-Low'</i> (<i>R. aromatica 'Gro-Low'</i>)	4' x 3'	low	sun	yellow	SP	ss/birds
PERENNIALS							
Common Yarrow	<i>Achillea millefolium (A.lanatum)</i>	18" x 18"	low-med	sun/part shade	white	S	np/bee, btf
Fringed Sage	<i>Artemisia frigida</i>	12" x 18"	low	sun	gray-green lvs.	S	p/bee; s/birds
Prairie Sage	<i>Artemisia ludoviciana</i>	18" x 18"	low	sun	gray-green lvs.	S	p/bee; s/birds
Showy Milkweed	<i>Asclepias speciosa</i>	30" x 12"	med	sun	pink	S	np/bee, btf; hp-monarch larva
Butterfly Milkweed*	<i>Asclepias tuberosa</i>	18" x 18"	low	sun	orange	S	np/bee, btf; o; hp-monarch larva
Chocolate Flower*	<i>Berlandiera lyrata</i>	18" x 18"	low	sun	yellow	S	np/bee, btf
Harebells	<i>Campanula rotundifolia</i>	12" x 6"	low	sun/part shade	blue	S	np/bee, btf
Purple Prairie Clover	<i>Dalea purpurea</i>	24" x 18"	low	sun	purple	S	np/bee, btf
Blanketflower	<i>Gaillardia aristata</i>	12" x 12"	medium	sun	yellow & red	S-F	np/bee, btf
Bush Sunflower	<i>Helianthus pumilus</i>	20" x 18"	low	sun	yellow	S-F	np/bee, btf; s/birds
Gayfeather	<i>Liatris punctata</i>	24" x 12"	low	sun	pink/purple	S-F	np/bee, btf
Blue Flax	<i>Linum lewisii</i>	18" x 12"	low	sun/part shade	blue	SP-S	np/bee, btf, o
Star Flower/Blazing-Star	<i>Mentzelia decapetala</i>	28" x 18"	low	sun	white	S	np/moths
Desert Four O'Clock*	<i>Mirabilis multiflora</i>	18" x 48"	low	sun/part shade	magenta	S	n/hm; n/hb
Bee Balm/Horsemint	<i>Monarda fistulosa</i>	24" x 24"	low-med	sun/part shade	pink/lav	S	np/bee, btf; n/hb
White-tufted Evening-Primrose	<i>Oenothera caespitosa</i>	6" x 12"	low	sun	white	S	n/hm; hp/hm
Howard's Evening-Primrose	<i>Oenothera howardii</i>	6" x 12"	low	sun	yellow	S	n/bee, moths
Side-bells Penstemon	<i>Penstemon secundiflorus</i>	20" x 12"	low	sun	lav/pink	SP-S	np/bee, btf; n/hb
Rocky Mountain Penstemon	<i>Penstemon strictus</i>	30" x 24"	low	sun/part shade	blue/purple	S	np/bee, btf; n/hb
Blue Mist Penstemon	<i>Penstemon virens</i>	12" x 12"	low	sun/part shade	blue/purple	SP-S	np/bee, btf; n/hb
Prairie Coneflower	<i>Ratibida columnifera</i>	18" x 12"	low	sun	yellow	S-F	np/bee, btf; s/birds
Black-eyed Susan	<i>Rudbeckia hirta</i>	24" x 7"	low	sun/part shade	yellow	S	np/bee, btf; s/birds
Pitcher Sage	<i>Salvia azurea</i>	36" x 36"	low	sun/part shade	blue/purple	S	n/hb, btf
Canada Goldenrod	<i>Solidago canadensis</i>	30" x 18"	medium	sun	yellow	S	np/bee, btf
Scarlet Globemallow	<i>Sphaeralcea coccinea</i>	10" x 10"	low	sun	red/orange	S	np/bee

Common Name	Scientific Name	Mature Size	Water	Exposure	Flower Color	Bloom Time	Wildlife Value
CACTI & SUCCULENTS							
Yellow Nipple Cactus	<i>Coryphantha (Escobaria) missouriensis</i>	4" x 4"	low	sun	yellow	S	np/bee, fruit
Pink Nipple Cactus	<i>Coryphantha (E.) vivipara</i>	4" x 4"	low	sun	pink	S	np/bee, green fruit
Prickly Pear	<i>Opuntia macrorhiza</i>	5" x 18"	low	sun	yellow/apricot	S	np/bee, red fruit
Plains Yucca	<i>Yucca glauca</i>	2' x 2'	low	sun	cream	S	hp- pronuba moth
GRASSES							
Indian Rice Grass	<i>Achnatherum hymenoides</i>	24" x 12"	low	sun	lacy tan inflr.	S	s/birds; hp-skipper
Side-Oats Grama	<i>Bouteloua curtipendula</i>	24" x 12"	low	sun	green	S	s/birds
Blue Grama	<i>Bouteloua gracilis</i>	18" x 12"	low	sun	green	S	s/birds
Little Bluestem	<i>Schizachyrium scoparium</i>	24" x 18"	low	sun	bluish foliage	S	s/birds; hp/skipper
SHRUBS							
Serviceberry	<i>Amelanchier alnifolia</i>	12' x 6'	low-med	sun/part shade	white	SP	frt/birds, wl
Silvery Leadplant	<i>Amorpha canescens</i>	4' x 3'	low	sun/part shade	purple	S	np/bee
Mountain Mahogany	<i>Cercocarpus montanus</i>	5' x 4'	low	sun/part shade	cream	SP	ss/birds, deer browse
Rubber Rabbitbrush	<i>Ericameria nauseosa (Chrysothamnus nauseosus)</i>	4' x 3'	low	sun	yellow	F	ss/birds; np/bee, btf, o
Apache Plume*	<i>Fallugia paradoxa</i>	5' x 5'	low	sun/part shade	white/pinkish	S	np/bee
Western Sandcherry	<i>Prunus besseyi</i>	4' x 4'	low	sun	white	SP	np/bee; frt/birds
Golden Currant	<i>Ribes aureum</i>	5' x 4'	medium	sun	yellow	SP	n/hb; frt/birds, wl
Wax Currant	<i>Ribes cereum</i>	4' x 3'	low	sun	pink/cream	SP	frt/birds, wl
Smooth Sumac	<i>Rhus glabra</i>	6' x 4'	low-med	sun/part shade	green/yellow	S	ss/birds
Skunkbush Sumac	<i>Rhus trilobata</i>	4' x 3'	low	sun	yellow	SP	ss/birds
Western Wild Rose	<i>Rosa woodsii</i>	3' x 4'	low-med	sun/part shade	pink	SP-S	np/bee; frt/birds
Snowberry	<i>Symphoricarpos occidentalis</i>	4' x 4'	low-med	sun/part shade	pink	S	np/bee, btf; frt/birds
TREES							
Rocky Mountain Maple	<i>Acer glabrum</i>	20' x 12'	med	sun	inconspicuous	SP	ss/birds
Rocky Mountain Juniper	<i>Juniperus scopulorum</i>	15' x 8'	low	sun	inconspicuous	S	ss/birds
Piñon Pine	<i>Pinus edulis</i>	25' x 15'	low	sun	inconspicuous	S	ss/birds
Ponderosa Pine	<i>Pinus ponderosa</i>	70' x 30'	low	sun	inconspicuous	S	ss/birds, wl
Gambel Oak	<i>Quercus gambelii</i>	25' x 12'	low	sun/part shade	inconspicuous		acorns/birds, wl; hp/CO hairstreak btf



Landscape Design #1

This landscape design, which is 15'x15' and approximately 22' diagonally, fits nicely into the corner of a yard. The leadplants serve as the tallest plant in the corner, contributing spikes of purple flowers when in bloom. The purple is repeated nearby by the purple prairie clover. The pale, fuzzy blue-grey leaves of prairie sage provide a soft muted color throughout the year as do the low, grey-green pussytoes at the front of the garden and the beautiful flowers of blue-mist penstemon that are abundant in spring and early summer. The native yarrow has flat-crowned clusters of small white flowers and ferny leaves with the white flower color echoed in the front by white-tufted evening primrose. The flowers of side-oats grama wave like small flags along the stem of the plant. The lovely blue flowers of flax bloom in the morning, shedding their petals like confetti on the ground by the afternoon. Garden design by Deryn Davidson.

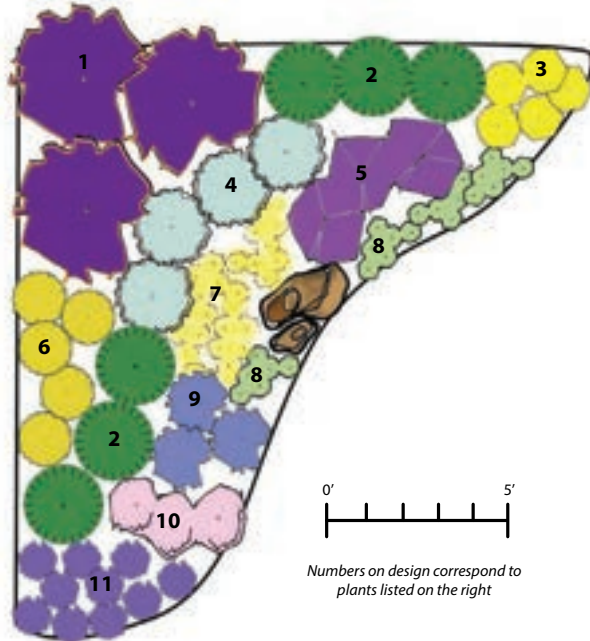

1. Leadplant
Amorpha canescens



2. Sideoats Grama Grass
Bouteloua curtipendula



3. Chocolate Flower
Berlandiera lyrata



4. Prairie Sage
Artemisia ludoviciana



5. Purple Prairie Clover
Dalea purpurea



6. Common Yarrow
Achillea millefolium



7. Spreading Daisy
Erigeron divergens



8. Pussytoes
Antennaria spp.

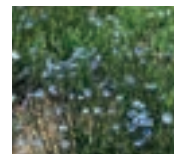

9. Blue Flax
Linum lewisii

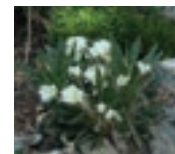

10. Evening-Primrose
Oenothera caespitosa

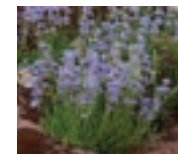

11. Blue Mist Penstemon
Penstemon virens

Landscape Design #2

This rectangular native garden is 15' x 5'. The rabbitbrush, pussytoes, and little bluestem give year round interest and winter structure. The flowers give a beautiful combination of summer and fall colors. Garden design by Deryn Davidson.



1. Goldenrod
Solidago spp.



2. Little Bluestem
Schizachyrium scoparium



3. Globemallow
Sphaeralcea spp.



4. Rky. Mtn. Penstemon
Penstemon strictus



5. Rabbitbrush
Ericameria nauseosa



6. Pussytoes
Antennaria spp.



7. Gayfeather
Liatris punctata



8. Chocolate Flower
Berlandiera lyrata

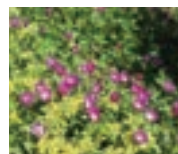

9. Wine Cups
Callirhoe involucrata

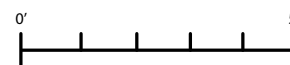

Numbers on design correspond to plants listed

PHOTO GALLERY OF LANDSCAPE IDEAS

Jim and Dorothy Borland's Yard is Habitat Hero Certified. It is a beautiful example of the mix of colors, textures and habitat provided by Colorado's native plants. Photo by Jim Borland.



David Julie's yard in Boulder - All of the grasses and forbs in the foreground are native short-grass prairie plants. Photo by David Julie.



Charlie and Jan Turner's native and xeriscape garden in Golden shows off the purple flowers of Rocky Mountain penstemon (*Penstemon strictus*) and blanket flower (*Gaillardia aristata*) with its bright yellow ray flowers and orange center of disk flowers. In front of the fence on the left side of the photo is a smooth sumac (*Rhus glabra*) that turns brilliant red in the autumn. A piñon pine can be seen behind the penstemons. To the right of the penstemon is a clump of sulphur flower (*Eriogonum umbellatum*). Photo by Jan L Turner.



The High Plains Environmental Center (HPEC) in Loveland has a number of native plant gardens. In the foreground are prairie sage (*Artemisia ludoviciana*), Hairy goldenaster (*Heterotheca villosa*), rabbitbrush (*Ericameria nauseosa*), tall evening primrose, and Rocky Mountain beeplant (*Peritoma serrulata*). Photo by Jim Tolstrup



Carol English & Dave Elin's Rock Garden is nestled into the rocky foothills in Morrison. Carol and Dave have artistically carved a number of rock gardens and paths that show off native shrubs, perennials (especially penstemons), evening-primroses, and cacti. Rock terraces and a variety of hardscapes show off the plants. Photo by Dave Elin.



Dave Sutherland's front yard, is a drought-tolerant garden occupying a corner between the driveway and the street. Photo by Jan L Turner



Rick Brune's Prairie Garden in Lakewood is a riot of color. He created a prairie of native plants on his large lot and it is next to impossible to capture the beauty and size of his prairie garden in photos. Some plants take turns blooming and, when they do, they may bloom in profusion!



Wallflowers (*Erysimum asperum*), sticky gilia (*Aliciella pinnatifida*), orange paintbrush (*Castilleja integra*), and broadbeard penstemon (*Penstemon angustifolius*) are the most obvious plants in the photo. Photo by Rick Brune.



The Butterfly Pavilion's Discovery Garden has sunflowers (left) and rabbitbrush (right) for bees, butterflies, and other pollinators. Photo by Amy Yarger



Butterfly on rabbitbrush. Photo by Jan Turner



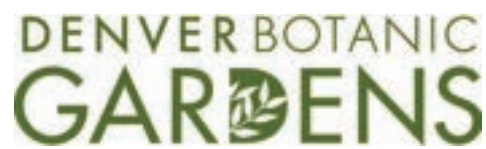

Colorado State University
EXTENSION

Published by the Colorado Native Plant Society, P.O. Box 200, Fort Collins, CO 80522
www.conps.org

Contributing Partners Include: Colorado Native Plant Society, Butterfly Pavilion,
CSU Extension Native Plant Master® Program, Denver Botanic Gardens, High Plains
Environmental Center, Front Range Chapter of Wild Ones

2017

This page intentionally left blank.



This page intentionally left blank.

Nesting & Overwintering Habitat

FOR POLLINATORS & OTHER BENEFICIAL INSECTS



FIGURE 1: By selecting native plants and managing habitat purposefully, even small wildflower plots (left) can provide high-quality overwintering habitat for pollinators and beneficial insects, like these small carpenter bees hibernating in a pithy stem (right).

Moving Beyond Flowers

While flowering plants provide pollinators with food, insects also require suitable shelter for nesting and overwintering. Most bees and wasps create small nests beneath the soil or within dead plant stems or cavities in wood. Other beneficial insects such as butterflies, wasps, moths, fireflies, lady beetles, and ground beetles seek shelter in places that offer protection from predators and the elements, such as leaf litter and brush piles.

The More, The Better

The primary habitat features used by pollinators and other insects for shelter include stems and branches of trees, shrubs, and wildflowers; leaf litter; undisturbed ground; bare ground; dead wood; brush piles; and rock piles. Retaining and incorporating as many of these features as possible into your landscape (rather than "cleaning" them away) will help attract and support a diversity of bees and other beneficial insects.

Why Natural Is Best

The availability of nesting and overwintering habitat is one of the most important factors influencing populations of native bees and other beneficial insects. Yet, traditional

landscaping practices rarely leave enough natural resources to support pollinators and other wildlife. This guide focuses on a variety of natural nesting habitat features that can be readily incorporated into most landscapes. Compared to artificial nesting options such as bee blocks and bee hotels, natural nesting habitat features often better mimic the natural nest site density of insects, and also break down naturally with time, limiting disease and parasite issues. Moreover, natural nesting features often provide multiple conservation benefits. An appropriately managed wildflower planting, for example, can provide nesting sites, pollen, and nectar for bees; host plants and overwintering habitat for butterflies; and abundant food for songbirds.

Our **Bring Back the Pollinators** campaign is based on four principles:

1. **Grow** a variety of pollinator-friendly flowers;
2. **Protect and provide** bee nest sites and caterpillar host plants;
3. **Avoid** using pesticides, especially insecticides; and
4. **Spread the word!**

You can participate by taking the **Pollinator Protection Pledge** and registering your habitat on our nationwide map at:
www.bringbackthepollinators.org



BLOOM

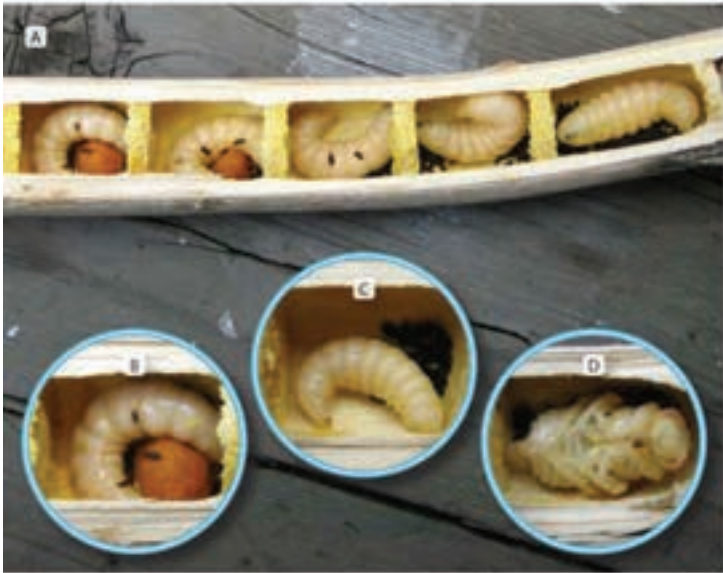

Figure 2: Located in a yucca stem (*Yucca* sp.), this opened large carpenter bee (*Xylocopa* sp.) nest shows multiple cells (A). In the cells closest to the nest entrance, larvae are still consuming pollen (B); while, further into the nest, larvae have consumed their provisions (C) and are preparing to pupate (D).

Figure 3: Stem "stubble" created from the previous year's wildflowers (A, stiff goldenrod plant [*Solidago rigida*]) provides excellent nesting opportunities for stem-nesting bees, such as small carpenter bees (B).



Save the Stems

Many hollow or pithy plant stems and branches provide excellent places for cavity-nesting insects to call home. Small carpenter bees (*Ceratina* spp.) frequently carve out their nests in last year's dead raspberry (*Rubus* spp.) canes or wildflower stems, often only a few inches away from the blossoms that provide pollen to feed their young. Still tinier yellow-faced bees (*Hylaeus* spp.) use the hollow center of smaller stems, like bee balm (*Monarda* spp.) or roses (*Rosa* spp.), and larger leaf-cutter bees (*Megachile* spp.) prefer the larger stems of plants like native thistles (*Cirsium* spp.), cup plant (*Silphium perfoliatum*), or desert willow (*Chilopsis linearis*). The biggest stem-nesting bees in North America, large carpenter bees (*Xylocopa* spp.), sometimes use the pithy stems of large plants like yucca (*Yucca* spp.) and agave (*Agave* spp.) in regions where wood is uncommon or unavailable. Other common occupants of dead stems and twigs include cavity-nesting wasps, stem-boring moths, and even some spiders. In addition, some beneficial insects insert their eggs into the stems of wildflowers and grasses for safe keeping over the winter.

ACTIONS:

- ✦ First, ensure your landscape supports a diversity of native shrubs such as elderberry (*Sambucus* spp.), sumac (*Rhus* spp.), and raspberries (*Rubus* spp.), as well as a diversity of wildflowers. For regional lists of plant species that are known to provide sites for nesting, visit <https://xerces.org/providing-nest-sites-for-pollinators/>.
- ✦ In a wildflower garden, leave flower stalks (and seed heads) intact over the winter. Many birds and other wildlife feed on the seeds of plants, including sunflowers (*Helianthus* spp.), asters (*Symphyotrichum* spp.), goldenrod (*Solidago* spp.), purple coneflowers (*Echinacea* spp.), blazingstars (*Liatris* spp.) and Joe Pye weed (*Eupatorium* spp.). Begin pruning dead flower stalks in the early spring, to create nest sites shortly before the first bees start flying.
- ✦ When pruning dead wildflowers, make your cuts at a variety of heights from about 8–24" above the ground. This creates vertical nesting opportunities in a variety of diameters, suitable for insects of different body sizes. The tops of the plants can go into a mulch or compost pile, or be bundled together and left in a sheltered place (either vertically or horizontally) to create additional nesting opportunities.
- ✦ Shrub pruning can occur any time that is compatible with the plant at hand, but typically occurs in late spring before the plant breaks dormancy. Create cut ends in a variety of diameters across the plant, which will simulate the nesting sites created by deer browsing.

- ✦ When pruning to expose cut ends, be sure that the nest sites you are leaving are at least 4–6" from a branch or stem node. Plants with pith-filled or hollow centers should be prioritized for nest-site pruning, since these will be more attractive than shrubs that have solid centers.
- ✦ As the weather warms, watch your new nesting sites for insect activity. It is not uncommon to see bees checking out multiple stems for suitability, and eventually settling on the perfect stem to call home. Stems that have been blocked at the cut end with natural materials such as leaves, mud, pebbles, grass, or resin indicate that there is a nest inside. Stems with unblocked cut ends may also be occupied by overwintering adults. Use your observations to guide future plantings and pruning decisions (e.g., stubble height) in your garden.
- ✦ Remember to leave cut stems in place during spring clean-up the following year, as they may be housing insect larvae, pupae, or overwintering adults.

Figure 4: Prune shrubs to create cut ends that serve as nest entrances for stem nesting bees (A). When pruning, the tops that you cut off can be bundled to create additional habitat. After being cut to 6" lengths and bundled, these stems were occupied by yellow-faced bees (*Hyloaeus* spp.) and aphid hunting wasps (B, *Pemphredon* sp.).



How to Create Habitat for Stem-Nesting Bees



WINTER

Leave dead flower stalks intact over the winter

SPRING

Cut back dead flower stalks leaving stem stubble of varying height, 8 to 24 inches, to provide nest cavities.



Female bees find cut or naturally occurring open stems, start a nest, then lay an egg on the pollen balls. Larvae eat the pollen.



SUMMER

New growth of the perennial hides the stem stubble.



Bee larvae develop in cut dead stems during the growing season.



FALL



WINTER



Bees hibernate in stems during the winter



SPRING

Cut back dead flower stalks. Old stem stubble will naturally decompose.



Adult bees emerge and start nests in newly cut dead stems or in naturally occurring open stems.





Figure 5: Fallen leaves (A) have all the properties and benefits of wood mulch (moisture retention and weed control) and are vital resources for overwintering pollinators and beneficial insects, like red-banded hairstreak (B, *Calycopsis cecrops*) larvae and bumble bee (C, *Bombus* sp.) queens.

2

Leave the Leaves

In cold climates, the vast majority of butterflies and moths use leaf litter for winter protection of eggs, caterpillars, chrysalises, or adults. For example, great spangled fritillary (*Speyeria cybele*) and woolly bear (*Arctiini*) caterpillars tuck themselves into a pile of leaves for protection from cold weather and predators. Red-banded hairstreaks (*Calycopsis cecrops*) lay their eggs on fallen oak (*Quercus* spp.) leaves, which become the first food of the caterpillars when they emerge. Luna moths (*Actias luna*) encase their cocoons in leaves and the chrysalises of swallowtail butterflies (*Papilio* spp.) resemble dried leaves, blending in with the real leaves. Some overwintering queen bumble bees (*Bombus* spp.) also rely on leaf litter for protection. At the end of summer, the mated queens burrow an inch or two into the earth to hibernate; an extra thick layer of leaves is welcome additional protection from the elements. In addition to these pollinators, there are many, many other animals that live or overwinter in leaves: lace bugs, snails, worms, beetles, millipedes, mites, spiders, and more—which in turn support the chipmunks, turtles, birds, and amphibians that rely on these invertebrates for food. Leaves also help plants weather spring freeze-thaw cycles by providing additional insulation to their root systems.

ACTIONS:

- ✦ Leave a thin layer of leaves on any lawn areas. While a couple of inches or more could smother the turf, research has shown that a thin layer of leaves actually benefits lawns, since decomposing leaves provide organic matter and nutrients to help lawns grow.
- ✦ If leaving leaves on your lawn isn't an option, rake them up and spread them over vegetable or flower beds, where they will help to build soil and provide habitat.
- ✦ Pile leaves around ornamental trees, shrubs, and perennials for mulch. Fallen leaves have the same weed suppression and moisture retention properties of shredded wood mulch—and they're free!
- ✦ Consider reducing your overall lawn footprint, replacing it instead with wildlife supporting plantings that can be future repositories for fall leaves. Leaves, along with cardboard and other compostable materials, can also be used to smother existing grass when converting lawn areas to habitat.
- ✦ When moving leaves, opt for raking or using a leaf vacuum to capture whole leaves, rather than shredding them with a mower.
- ✦ While the idea is to "leave the leaves" permanently—if you do decide to remove some of the leaves in spring, make sure you wait until late spring to increase the chances of successful emergence by butterflies, queen bumble bees, and other overwintering animals.



Figure 6: Join the Xerces Society's social media campaign to "leave the leaves" by using the hashtag #leavetheleaves.



Figure 7: Many common native bee species—such as mining bees (A, *Andrena* sp.), cellophane bees (B, *Colletes* sp.), and sweat bees (C, *Agapostemon* sp.)—are often found nesting in areas with bare soil or patchy vegetation in residential lawns or parks.

Redefine the “Perfect” Lawn

3

Roughly 70% of our native bee species nest in the ground, where they are often found in loose, undisturbed soil, and patches of bare soil without a lot of dense vegetation or sod. Ground-nesting bees are often confused with aggressive ground-nesting social wasps. Here are a few key differences: social wasps are active all summer long and tend to actively defend their nest, with a large number of workers protecting their underground larval brood. In contrast, solitary bees are not aggressive, their nests very small (just one foraging adult mother and a handful of underground larvae), and they are active for only a very short period (a few days to weeks while the mother is filling the nest with food). As a result, solitary bee nests often go unnoticed, though there can be many nests in the same area, making them easier to locate. Ground-nesting behavior is found in the vast majority of our native bees, including long-horned bees (*Melissodes* spp.), squash bees (*Peponapis* spp.), mining bees (*Andrena* spp.), polyester bees (*Colletes* spp.), and many sweat bees (*Halictus* spp.). Many of these bees are among the earliest pollinators to emerge in spring, and are essential pollinators of early-blooming fruit tree crops, as well as spring ephemeral wildflowers and native trees and shrubs.

ACTIONS:

- ❏ Reduce lawn size where possible, replacing lawn with native flowering plants as well as native bunchgrasses and clump-forming native sedges. These grasses and sedges are useful in supporting ground nesting bees, since they grow with a space around the plant where bees can access bare soil, even in densely vegetated areas. Limit turf grass to select areas, such as accents or as garden paths.
- ❏ Retain a variety of “microhabitats” in your yard or lawn, including patches of bare ground where possible. Although unsightly to some, bare spots in turf grass provide ground nesting bees and other insects with access to a very important resource: soil.
- ❏ Plant a bee lawn, composed of short-statured grasses and wildflowers that tolerate some foot traffic and need less water, mowing, and fertilizer than typical turfgrass. These plants are naturally patchy, leaving room for nest sites.
- ❏ Set mower blades to the highest setting, and reduce mowing frequency. Lawns mown every two to three weeks have more flowers like dandelions and clover. These flowers, though non-native, provide food for a surprising diversity of bees. Ground-nesting bees often nest in close proximity to the plants from which they forage.
- ❏ Leave some areas of your lawn unmown. Tall grass can provide shelter for butterflies, moths, fireflies, and lacewings, as well as nesting habitat for small mammals, which in turn supports the nesting needs of many bumble bees.
- ❏ Avoid chemical fertilizers, herbicides, and insecticides in your lawn, many of which have unknown or negative consequences to bees and other soil-dwelling insects.

Figure 8: Mining bee (*Andrena* sp.) nest entrance (circled) in an area of patchy lawn.



Build a Rock Pile or Rock Wall

Rock piles, rocky embankments, rock walls, and similar structures provide important habitat for a diversity of beneficial insects and other wildlife. Leafcutter bees (*Megachile* spp.) make nests in the cracks or crevices present in some types of rock. Other tunnel-nesting bees, such as some digger bees (*Anthophora* spp.), use water to soften sandstone and excavate into it. Bumble bees (*Bombus* spp.) make homes in protected cavities inside rock piles and walls, while ground beetles (*Carabidae*) and numerous other beneficial insects find shelter at the interface between soil and stone.

ACTIONS:

- ▲ To build a rock pile, include a diversity of rock types and sizes, and assemble with a "messy" configuration. This helps ensure that there are air spaces in the pile, and that access to ground is available under some parts of the pile.
- ▲ Consider incorporating native bunchgrasses around the pile, to help support nesting by bumble bees and overwintering by ground beetles and other insects.
- ▲ Wildflowers around the pile will make it more attractive to pollinators and beneficial insects that feed on nectar/pollen during part of their life cycle, and will also provide seeds for birds and small mammals.
- ▲ If building a rock wall, choose a dry wall construction method, since this provides more crevices in which insects can find shelter.



Figure 14: Rock walls at the University of Wisconsin Arboretum provide nesting habitat for mud dauber wasps and bumble bees, including the endangered rusty-patched bumble bee (*B. affinis*).

BUMBLE BEE NESTING

Bumble bees are social insects that nest in a variety of pre-existing cavities (hollow logs, spaces in rock walls, under bunchgrasses, in bird nest boxes, etc.). Their nests are often found in abandoned rodent burrows, where the soft, fuzzy lining helps protect and insulate the nest. Bumble bee nests can be hard to find, unless you happen to notice bees going in and out of the nest. As long as the immediate area around the nest is avoided, there is very little risk of getting stung by bumble bees nesting in your yard.

Figure 15: If space is an issue, unmortared natural rock retaining walls or raised flower beds can provide nesting places for habitat for mining bees (*Andrena* sp. A), bumble bees (*Bombus* sp. B), and leafcutter bees (*Megachile* sp. C).



Constructing a brush pile is an effective way to provide habitat for a diversity of beneficial insects and other wildlife. Brush piles provide hibernation sites for mourning cloaks (*Nymphalis antiopa*) and other butterflies, soil access for ground nesting bees, daytime shelter for fireflies (Lampyridae), and food for a diversity of wood-eating beetles and other organisms that eventually break the piles down into valuable organic matter for your yard. Larger animals also benefit from brush piles. Chickadees, warblers, and other songbirds enjoy the hiding spaces provided by the branches, and small mammals create warm burrows in the pile that later provide protected spaces for bumble bees (*Bombus* spp.) to nest.

In most municipalities, local waste management authorities will collect curbside brush and either chip and compost it or haul it off to a landfill. If everyone retained just a small amount of their clippings and prunings, we could reduce the burden on our waste management system. In rural areas, brush is often burned on site, a practice which not only adds carbon dioxide to the atmosphere, contributing to climate change, but also wastes valuable organic material that could be retained on site.

ACTIONS:

- ❏ Select an out-of-the-way location for your brush pile, such as a fence corner, woodland edge, or around a large tree.
- ❏ Begin the brush pile by placing larger branches or logs on the bottom, along with any stones, so that your pile has a sturdy base.
- ❏ Continue to stack branches and logs, layering them crosswise with small limbs and brush on the top, or pile the branches in a conical shape around a large central log or stump.
- ❏ Aim for 2–8' high, and 3–10' in diameter (depending on the space and resources available).
- ❏ Structure the pile to have plenty of air spaces on the sides and in the interior of the pile. While insects can find space in almost any pile, birds and small mammals will benefit from holes at least 6" wide along the sides and throughout the pile.
- ❏ As the brush pile settles, you can add to it, or create a new pile.
- ❏ Retired brush piles are excellent places to plant raspberries (*Rubus* spp.) or other shrubs, since the decomposing brush provides abundant organic matter and weed control.
- ❏ Your brush pile can also be the base of a raised hugelkultur garden. Start with a 3-foot-high brush pile, water the pile, fill in spaces with leaf litter or compost, top with a few inches of top soil and a thin layer of mulch, and plant seeds or transplants.
- ❏ If you are worried about your pile being an eyesore, consider hiding the pile behind a hedge or wildflowers, building a "brush fence", or simply installing a Pollinator Habitat sign to advertise your good intentions to your neighbors.

FIGURE 13: In rural areas, larger brush piles should be left to decompose naturally (A), rather than burned. In yards or parks, a "woven" wildlife habitat feature (B) or raised hugelkultur (C) garden built on top of a brush pile filled in with leaves, compost, and mulch, could create attractive habitat, once established.



Save a Snag and “Plant” a Log

5

Dead standing trees (snags) are often quickly removed from our managed landscapes due to aesthetics or safety concerns. However, in many cases a snag poses no real danger, and if left in place, the dead woody material provides an abundance of habitat for a wide diversity of wildlife, including woodpeckers, owls, and of course insects. Long-horned beetles (Cerambycidae), jewel beetles (Buprestidae), and bark beetles (Scolytinae) are just a few of the insects that can be found burrowing through recently dead wood, activities which create perfect chambers in which cavity-nesting bees such as mason bees (*Osmia* spp.) and leaf cutter bees (*Megachile* spp.) can lay their eggs.

Similarly, fallen logs also provide a plethora of resources for insects. The moist spaces under logs and behind peeling bark are attractive to spiders, ground beetles (Carabidae), and other insect predators, while bees and butterflies are more likely to nest and overwinter in dryer parts of logs. Many larger animals will also appreciate log habitat additions: chipmunks use logs as “runways” through a landscape; tree frogs are attracted to the moisture provided by well-decomposed logs; and skinks and lizards enjoy the surface of logs for basking in the sun.

ACTIONS:

- ✚ Retain any dead standing trees in place as long as they do not pose safety concerns. If safety is an issue, fell the tree and leave the log in place, or move it to another part of the yard or landscape.
- ✚ If logs or snags are lacking in your yard, consider “planting” a log that is destined for disposal from a neighboring yard or park. Note that moving dead wood across longer distances is not allowed in some areas; check your local natural resource authorities for details. Also, do not relocate any fallen wood that was removed due to insect pests or diseases.
- ✚ When “planting” a log, give preference to hardwood logs with the bark still attached. This will result in longer-lasting woody habitat. Lay the log horizontally on the ground, burying one end of the log a few inches into the soil to maintain some moisture, and surrounding parts of the log with a few smaller branches or rocks to provide extra cover and improved habitat.



Figure 11: Beetle exit holes in dead cottonwood tree; these abandoned tunnels make nice homes for cavity-nesting bees.

Figure 12: In addition to supporting wildlife, snags attract solitary species that nest in cavities under bark (A, bufflehead mason bee [*Osmia bucephala*]), or in old beetle holes (B, aphid hunting wasps [*Amphredon* sp.]). To identify occupied nests, look for entrances “capped” with mud or plant matter (C, circled).





Figure 9: Many solitary bee species can be found nesting in soil with pebbles on the surface, like this small sweat bee (A, *Lasioglossum* sp.) poking her head out of ground nest among pebbles; and this striped sweat bee (B, *Halictus* sp.) observed exiting her nest.

Different types of mulch can influence how easily ground nesting bees can reach the soil to create their nests. Some mulch can also support beneficial insects and spiders by providing shelter.

ACTIONS:

- 🚫 Avoid landscaping with plastic mulch, landscape fabric, and heavy wood chips, especially chemically treated or colored wood chips. Not surprisingly, these impenetrable layers can limit nesting sites for ground nesting bees.
- 🚫 Use a shallow layer of pebbles as rock mulch. Bees can still reach small patches of soil, and some even prefer to nest among pebbles over bare ground (e.g., the widely-distributed orange-legged furrow bee [*Halictus rubicundus*]).
- 🚫 Use compost, leaf litter, and plant debris from your wildflower gardens, rather than wood mulch. Compared to wood mulch, a layer of leaf litter or other loose mulch allows ground-nesting bees easier access to their nest entrances.
- 🚫 If using bark or wood mulch, create a light layer rather than a thick layer. Mulch only the first foot or so into the garden from your path, leaving the rest of your garden with bare soil under the plants.
- 🚫 Consider "reversing" the mulch in your yard. Instead of using mulch around plants, use leaves in gardens and reserve heavy mulch for walking paths.

Figure 10: When mulching a potential nesting site, a little goes a long way. Make sure to spread any mulch (A), leaf litter (B), or gravel (C) shallowly enough that bees can still reach the soil underneath to dig their nests (circled).



8

Provide a Safe Water Source

Honey bees (*Apis mellifera*) and bumble bees (*Bombus* spp.) are familiar visitors to bird baths during warm weather, but they're not the only species that require access to a safe water source. Paper wasps (*Polistes* spp.) are social nesters that also collect water to make paper and to cool their colonies in hot weather. In addition to these social groups, some solitary bees, like mason bees (*Osmia* spp.) and solitary wasps (e.g., potter wasps, Eumeninae) need mud to create their nests. In drier weather (when mud is not available), they will frequently collect water in their crops and then carry it to dirt in order to make their own mud. Other ground-nesting species, like digger bees (*Anthrophora* spp.) and the blue mud-dauber wasp (*Chalybion californicus*) also collect water in their crops, but they use it to soften the ground where they dig their nests. Some digger bee species make up to 80 water-collecting trips a day when excavating their nests. Since many native bees and wasps will resort to collecting water from puddles and ditches when other sources are unavailable, they can run the risk of exposure to harmful pollutants and pesticides. Providing a shallow source of unpolluted water for bees and wasps can improve their overall chances of nesting successfully by reducing the time needed to forage, as well as the risk of exposure to pesticides.



FIGURE 16 Provide bees and wasps with water to create their nests with a shallow bird bath or bowl and a safe place to perch.

ACTIONS:

- Provide a shallow source of water—such as a bird bath or bowl with stones on which bees and wasps can perch safely without slipping—in a sunny place near potential nesting sites.
- Clean the water source regularly to prevent mosquitoes from proliferating, but don't worry about dirt or organic matter in the water—there are minerals not present in nectar and pollen that bees obtain from "dirty" water.

9

Install a Habitat Sign

Consider installing a Pollinator Habitat sign to advertise your new landscape features. Not only does a sign help to explain your objectives, it's also an opportunity to inspire neighbors to think about their own role in making landscapes more sustainable for pollinators.

FIGURE 17 Your garden can support a bounty of beneficial insects all year long. Let your neighbors know the "mess" is intentional by posting a pollinator or wildlife habitat sign.



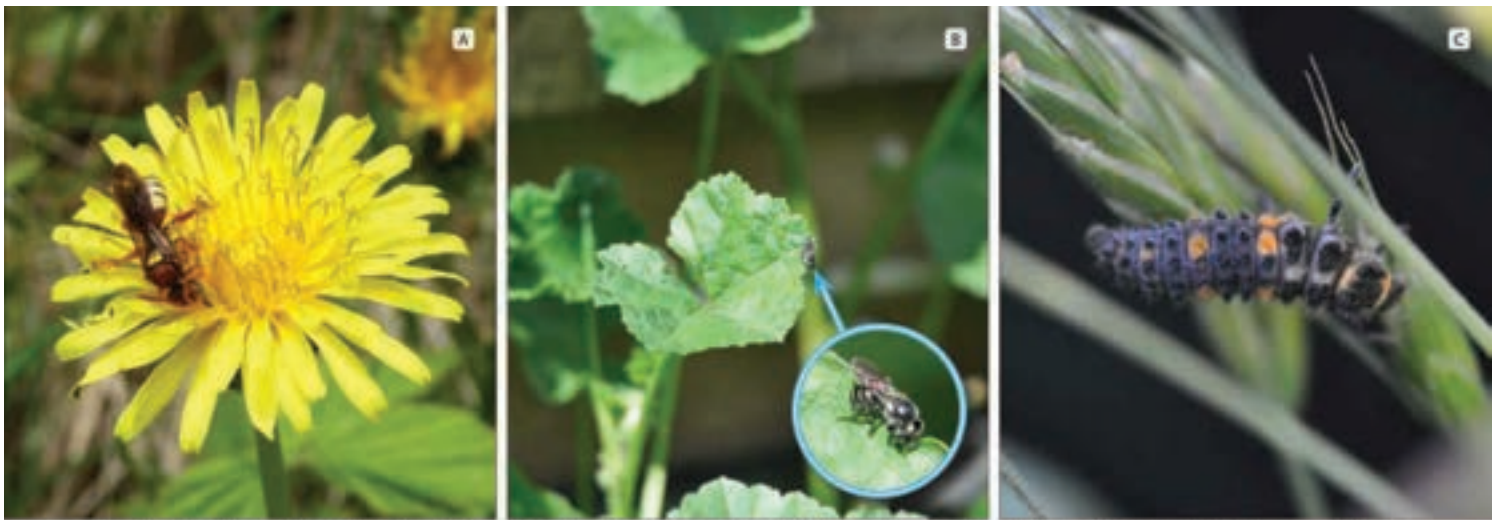

Figure 18: While they may be unwanted additions to a lawn or garden, some weedy species provide critical resources for pollinators and beneficial insects looking for places to forage or collect nesting materials. From left to right: A, cuckoo bee (*Nomada* sp.) foraging on dandelion (*Taraxacum* sp.); B, a small mason bee (*Hoplitis* sp.) collecting pieces of mallow leaves (*Malva* sp.) for lining the cells of its nest; C, convergent lady beetle (*Hippodamia convergens*) larva seeking smaller insect prey in tall grass.

Resources & References

Providing Nest Sites for Native Pollinators

The Xerces Society

Includes plant lists for species that provide nesting material and resources for maintaining artificial nests.

xerces.org/providing-nest-sites-for-pollinators

Bee Nesting Plants Survey

The Xerces Society

You can help! Use this link to let us know about your observations of plants used by bees for nesting.

<https://bit.ly/2YdWg3n>

Habitat Assessment Guide for Pollinators in Yards, Gardens, and Parks

The Xerces Society

Evaluate pollinator habitat at a given urban, suburban, or rural site and identify areas for improvement.

www.xerces.org/publications/habitat-assessment-guides/habitat-assessment-guide-for-pollinators-in-yards-gardens

Regional Pollinator Plant Lists

The Xerces Society

Recommended native plants that are highly attractive to pollinators.

xerces.org/pollinator-conservation/plant-lists

Attracting Native Pollinators: Protecting North America's Bees and Butterflies

The Xerces Society

xerces.org/announcing-the-publication-of-attracting-native-pollinators

Farming with Native Beneficial Insects: Ecological Pest Control Solutions

The Xerces Society

xerces.org/farming-with-native-beneficial-insects

Bees In Your Backyard: A Guide to North America's Bees

Princeton University Press

<https://press.princeton.edu/titles/10593.html>

Habitat Network website

Cornell University and The Nature Conservancy

Information on how to provide fallen log habitat, remove lawn, and more.

<http://content.yardmap.org>

Gardening and Landscaping Practices for Nesting Native Bees

Utah State University Extension

https://digitalcommons.usu.edu/cgi/viewcontent.cgi?article=1723&context=extension_curall

Managing Bee Lawns

University of Minnesota Bee Lab

www.beelab.umn.edu/bees/beelawn

How to Create Habitat for Stem-nesting Bees

University of Minnesota Bee Lab

<https://z.umn.edu/stemnestingbees>

Bees: An Identification and Native Plant Forage Guide

Pollination Press, LLC

Includes extensive nesting information for each bee genus, along with foraging and other details.

www.pollinationpress.com/books.html

Ground Nesting and Cavity Nesting Bee Posters:

Pollination Press, LLC

www.pollinatorsnativeplants.com/plant-lists--posters.html



BLOOM



FIGURE 19: Incorporating natural habitat features—such as pithy-stemmed plants (A), logs (B, C), patches of undisturbed soil (D), and leaf litter (E, F)—into a garden or urban space can provide important nesting and overwintering sites for pollinators and beneficial insects.

Acknowledgments

Authors: Sarah Foltz Jordan, Jennifer Hopwood, and Sara Morris of The Xerces Society for Invertebrate Conservation.

Reviewers: The authors would like to thank Elaine Evans, Heather Holm, Colleen Satyshur, Eric Lee-Milder and Matthew Shepherd for review of this document.

Layout: Sara Morris, the Xerces Society.



Development of this guide was supported by funding from the Minnesota Environment and Natural Resources Trust Fund and the USDA Natural Resources Conservation Service. Additional support was provided by Annie's, Cascadian Farm, Ceres Trust, Cheerios, CS Fund, General Mills, Justin's, Muir Glen, and Nature Valley.

Photographs & Artwork

How to Create Habitat for Stem-Nesting Bees graphic on page 3 provided by Colleen Satyshur, Elaine Evans, Heather Holm, and Sarah Foltz Jordan. We thank the photographers who generously allowed use of their images. Copyright of all photographs remains with the photographers:

- ↪ Courtney Celley / USFWS Midwest Region [flickr.com/usfwsmidwest]: Figure 13C.
- ↪ John Flannery [flickr.com/drphotomoto]: Figure 5B (photograph).
- ↪ Jenn Forman Orth [flickr.com/jrtica]: Figure 19B.
- ↪ Brian Henderson [flickr.com/stinkenroboter]: Figure 13B.
- ↪ Heather Holm [www.pollinatorinativeplants.com]: Figures 3B; 7A–B; 10A; 12C; 15A; 19A & C.
- ↪ Ilona Loser [flickr.com/woolcanderbee]: Figure 12A.
- ↪ Sean McCann [flickr.com/deadmike]: Figures 9B; 16 (top).
- ↪ Steven Severinghaus [flickr.com/horsepunchkid]: Figure 5C.
- ↪ Vicky Somma [flickr.com/tgms]: Figure 15B.
- ↪ Robin Williams, via Nigel Jones [flickr.com/insectman]: 12B.
- ↪ The Xerces Society / Kitty Bolte: Figure 19F.
- ↪ The Xerces Society / Candace Fallon: Figure 10B.
- ↪ The Xerces Society / Sarah Foltz Jordan: Figures 1; 3A; 4A; 8; 11; 13A; 18A; 19 (main), 19B.
- ↪ The Xerces Society / Jennifer Hopwood: Figures 9A; 14.
- ↪ The Xerces Society / Ray Moranz: Figure 13C.
- ↪ The Xerces Society / Sara Morris: Figures 1A, C, E; 4B; 7C; 16 (bottom); 18B–C.
- ↪ The Xerces Society / Matthew Shepherd: Figures 10C; 17; 19D.
- ↪ The Xerces Society / Katharina Ullmann: Figure 2.
- ↪ The Xerces Society / Justin Wheeler: Figures 5A (photograph & artwork); 5B (artwork); 6 (artwork).

This page intentionally left blank.



This page intentionally left blank.

Maintaining Diverse Stands of Wildflowers Planted for Pollinators

Ongoing Management of Pollinator Habitat

Hillary Sardiñas, Jennifer Hopwood, Jessa Kay Cruz, James Eckberg, Kelly Gill, Rae Powers, Sarah Foltz Jordan, Mace Vaughan, Nancy Lee Adamson, and Eric Lee-Mäder



 XERCES
SOCIETY
for Invertebrate Conservation



BLOOM



Maintaining Diverse Stands of Wildflowers Planted for Pollinators

Ongoing Management of Pollinator Habitat

Hillary Sardiñas
Jennifer Hopwood
Jessa Kay Cruz
James Eckberg
Kelly Gill
Rae Powers
Sarah Foltz Jordan
Mace Vaughan
Nancy Lee Adamson
Eric Lee-Mäder

The Xerces Society for Invertebrate Conservation

www.xerces.org



The Xerces® Society for Invertebrate Conservation is a nonprofit organization that protects wildlife through the conservation of invertebrates and their habitat. Established in 1971, the Society is at the forefront of invertebrate protection, harnessing the knowledge of scientists and the enthusiasm of citizens to implement conservation programs worldwide. The Society uses advocacy, education, and applied research to promote invertebrate conservation.

The Xerces Society for Invertebrate Conservation
628 NE Broadway, Suite 200, Portland, OR 97232
Tel (855) 232-6639 Fax (503) 233-6794 www.xerces.org

Regional offices coast to coast.

The Xerces Society is an equal opportunity employer and provider. Xerces® is a trademark registered in the U.S. Patent and Trademark Office



© 2018 by The Xerces Society for Invertebrate Conservation

Acknowledgements

This material is based upon work supported by the Natural Resources Conservation Service, U.S. Department of Agriculture, under agreement number 69-3A75-12-253. Any opinions, findings, conclusions, or recommendations expressed in this publication are those of the author(s) and do not necessarily reflect the views of the U.S. Department of Agriculture.

Additional support provided by Cascadian Farm, Ceres Trust, Cheerios, CS Fund, Disney Conservation Fund, The Dudley Foundation, Endangered Species Chocolate, Gaia Fund, General Mills, Irwin Andrew Porter Foundation, J. Crew, National Co-op Grocers, Nature Valley, Sarah K. de Coizart Article TENTH Perpetual Charitable Trust, Turner Foundation, Inc., The White Pine Fund, Whole Foods Market and its vendors, Whole Systems Foundation, and Xerces Society members.

The authors would like to thank Cheri and Rob Bowers; Marcus Bradley; Van Burnette; The Gallagher Family, Erdman Farms; Marie Poteat; Russell Ranch Sustainable Agriculture Facility, University of California–Davis; Stephen Thomforde, Great River Greening; Thomas Ward, East National Technical Support Center Forester USDA–NRCS; and the USDA–NRCS Plant Materials Center in Lockeford, CA. We thank Ray Moranz and Anne Stine for their contributions to the fire and grazing sections, and Kitty Bolte, Stephanie Frischie, Karin Jokela, Stephanie McKnight, Ray Moranz, Emma Pelton, Kat Prince, and Eric Venturini for their contributions on regional differences.

Editing and layout: Sara Morris, The Xerces Society.

Citation

Sardiñas, H., J. Hopwood, J. K. Cruz, J. Eckberg, K. Gill, R. Powers, S. F. Jordan, M. Vaughan, N. L. Adamson, and E. Lee-Mäder. 2018. *Maintaining Diverse Stands of Wildflowers Planted for Pollinators: Long-term Management of Planted Wildflower Habitat for Pollinator Conservation*. 52 pp. Portland, OR: The Xerces Society for Invertebrate Conservation.

Photographs & Artwork

Cover: Native pollinator planting featuring *Gilia*, *Phacelia*, *Clarkia*, and *Grindelia*, in a California almond orchard.

We are grateful to the many photographers and designers for allowing us to use their wonderful photographs. The copyright for all photographs is retained by the creators. None of the photographs may be reproduced without permission from the creator. For a complete list of photographers, please see the Additional Acknowledgements section on page 49. If you wish to contact a photographer, please contact the Xerces Society at the address above.



BLOOM

Contents

1. Importance of Long-term Management	1
2. Characteristics of Functional Pollinator Habitat	2
3. Management Process	5
Monitoring, <i>page 5</i>	
Evaluation, <i>page 6</i>	
Management, <i>page 9</i>	
Re-evaluation, <i>page 10</i>	
4. Management Strategies	13
I. MOWING, <i>page 13</i>	
A. Mowing for Diversity, <i>page 14</i>	
B. Mowing for Weed Control, <i>page 15</i>	
II. HAND-WEEDING, <i>page 16</i>	
III. SPOT-SPRAYING, <i>page 17</i>	
IV. GRASS-SELECTIVE HERBICIDE, <i>page 18</i>	
V. WEED REMOVAL AROUND SITE EDGES, <i>page 18</i>	
VI. CONSERVATION HAYING, <i>page 19</i>	
VII. PRESCRIBED FIRE, <i>page 20</i>	
VIII. GRAZING, <i>page 21</i>	
A. Rotational Grazing, <i>page 22</i>	
B. Patch-Burn Grazing, <i>page 22</i>	
C. Grazing for Broadleaf Weed Control, <i>page 22</i>	
IX. REINTRODUCING WILDFLOWER DIVERSITY, <i>page 22</i>	
A. Interseeding, <i>page 22</i>	
B. Plug or Bare Root Planting, <i>page 24</i>	
X. IRRIGATION, <i>page 24</i>	
XI. STARTING OVER, <i>page 25</i>	
XII. EXTREME WEATHER CONDITIONS, <i>page 26</i>	
5. Deciding Which Management Technique to Use	27
Identifying Conditions, <i>page 27</i>	
Table 5.1: Common Site Conditions, <i>page 29</i>	
Selecting Management Treatment, <i>page 30</i>	
Decision Tree #1: Sites Dominated by Desirable Species, <i>page 31</i>	
Decision Tree #2: Sites with a Mixture of Desirable & Unwanted Species, <i>page 32</i>	
Decision Tree #3: Sites Dominated by Unwanted Species, <i>page 33</i>	
Recording Management Practices, <i>page 34</i>	

6. Management is a Moving Target	36
7. Case Studies	37
1. Oregon Blueberry Farm: Selectively Removing Non-Native Weeds, <i>page 37</i>	
2. Pennsylvania Apple Orchard: Managing Aggressive Weeds During Establishment, <i>page 38</i>	
3. California Almond Orchard: Balancing Wildflowers with Native Bunch Grasses, <i>page 39</i>	
8. Additional Resources	41
Appendix A: Regional Differences Table	43
Appendix B: Pollinator Habitat Forms	48
Appendix C: Additional Acknowledgments	49



Importance of Long-term Management

Land managers, including farmers, are increasingly integrating pollinator habitat into farms to support pollinators and the crop pollination services they provide. These habitats, which typically consist of wildflower-rich meadows or field-borders, often require some level of ongoing management to maintain high flower diversity and abundance for foraging pollinators. Poor establishment, poor seed quality, effects of succession (e.g., woody plants begin to shade out wildflowers), overly vigorous native flowers, and invasion of weedy species can all degrade the plant community, requiring management action to improve the habitat for pollinators. When coupled with active monitoring, ongoing habitat management is an efficient use of time and resources, capable of detecting and preventing problems before they degrade plant communities and adversely affect the pollinator value of the habitat.

This guide is intended to facilitate management of wildflower habitat in the years after initial establishment. First, we discuss the characteristics that impact the pollinator value of planted wildflower habitat, and then we review the key steps in the management process. Next, we summarize the management tools most likely to sustain wildflower populations, which support bees and other pollinators, and finally, we provide diagnostic tools to help select appropriate management techniques for an array of potential habitat conditions. The management techniques described here are best suited to pollinator habitats in agricultural environments that range in size from 0.5–5 acres; they can be applied in other contexts, but additional factors, such as sensitive or rare species and regulatory requirements, should be considered in natural habitats that are not covered in this document.

FIGURE 1.1: It's important to include wildflowers with overlapping bloom times so there is continuous bloom from spring through fall in pollinator plantings in order to support diverse pollinators. For example, in the upper Midwest, an array of wildflowers provides nectar for monarch butterflies (*Danaus plexippus*).

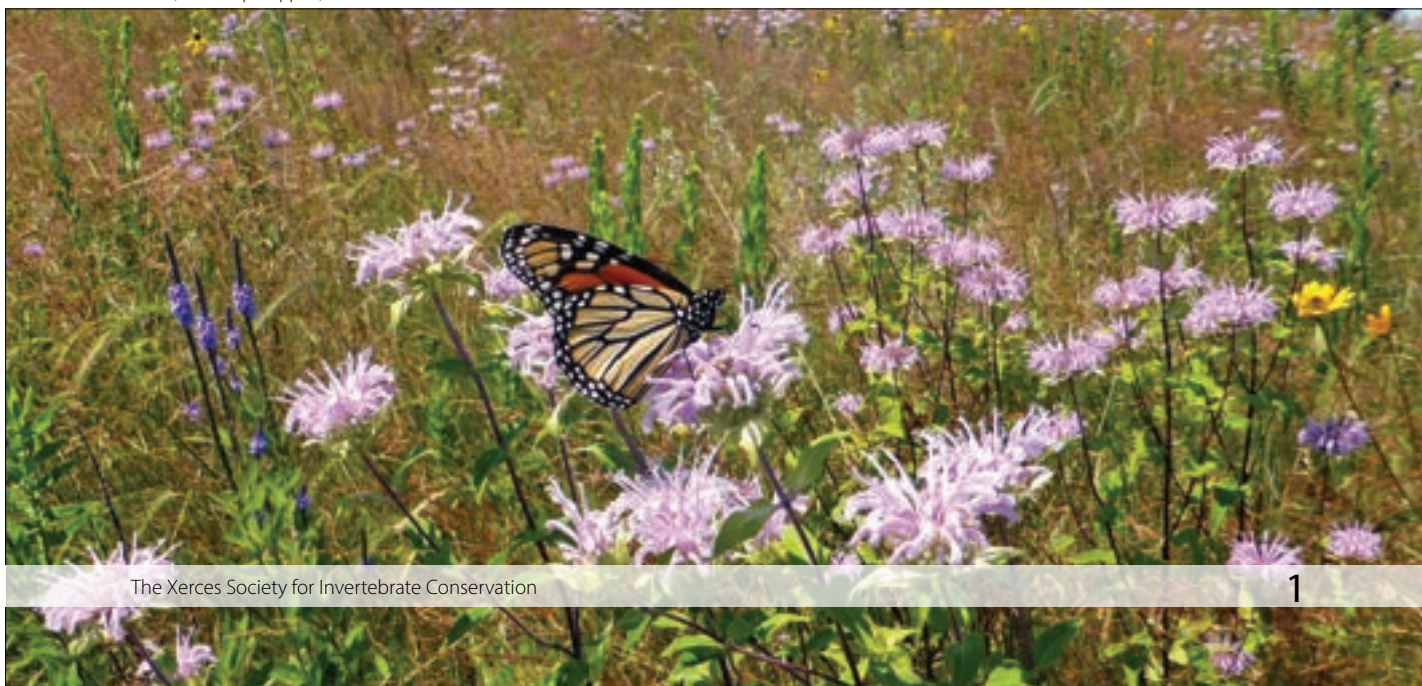

The Xerces Society for Invertebrate Conservation

1

2

Characteristics of Functional Pollinator Habitat

Before determining whether wildflower habitat requires management, it is helpful to know the conditions that best support pollinators. Functional pollinator habitat has multiple species of wildflowers that start blooming in early spring and continue through fall (exact timing depends on the region). Periods of bloom should overlap rather than leaving time periods when nothing is in bloom, also known as gaps in bloom. We define a gap in bloom as a two week period when there is less than 10% cover of blooming wildflower species. Different pollinators rely on different plant species; in order to support a robust pollinator community, wildflower habitat should contain a wide variety of native species present. Grasses (and flowering shrubs where regionally appropriate) are desired components in pollinator habitat. For example, grasses can provide vegetation structure, nesting or overwintering sites for pollinators and other wildlife, host plants for butterflies, fibrous root systems which diversify soil structure, help to buffer against weed invasion, and can be fuel for carrying prescribed burns which can benefit wildflowers. However, because some grasses can aggressively spread and eventually reduce wildflowers, the aim of managing for diversity is to limit their dominance.

FIGURE 2.1: This high value pollinator habitat in Minnesota provides diverse resources for bees, butterflies, and beneficial insects.



The key features of pollinator habitats that can support diverse, abundant populations of wild bees and other pollinators are:

- ⇒ A diversity of desirable, pollinator-attractive plant species, with no single species dominant.
- ⇒ Species that bloom in overlapping succession all season long (spring, summer, fall), with at least three species, ideally many more, blooming at any given time.
- ⇒ Dominant plants are wildflowers (some weeds may be present, but they are not outcompeting wildflowers).
- ⇒ Desired plant species persist over time.
- ⇒ If unwanted weedy species are present, they are non-invasive and unlikely to compete with desirable species.

It can be helpful to set specific goals for the planting and refer back to them to ensure the planting is fulfilling its intended function. An example goal would be: wildflowers provide bloom throughout the growing season and weedy species cover is low

Maintaining Diverse Stands of Wildflowers Planted for Pollinators



FIGURE 2.2: Example Pollinator Habitat Installation Plan

Example

POLLINATOR HABITAT INSTALLATION PLAN



STEP 1—Habitat Installation Record

- Print a copy of this form in advance (<https://www.xerces.org/habitat-assessment-guides>).
- Record all of the species initially seeded into the site and any desirable native species remaining after site preparation BEFORE the first monitoring (i.e., during or immediately after planting); AND
- Save a copy of your Plan to work from during each monitoring.

SITE NAME: Oregon Meadow INSTALLATION DATE: October 1, 2012

KEY SITE DETAILS that may impact wildflower establishment (e.g., weed pressure/species of concern, site history, soil characteristics, etc.)
bindweed, plainain, sorrel, and harding grass were removed from the site during using solarization, but will likely require additional management over time.

STEP 2—Site Preparation & Habitat Installation

Site preparation is one of the most important and often inadequately addressed components for project success. It is also a process that may require more than one season of effort to reduce competition from invasive, noxious, or undesirable plants prior to planting. In particular, site preparation should focus on the removal of perennial weeds (there are more options to address annual or biennial weeds after planting). For more information on recommended site preparation methods, see *Wildflower Establishment: Organic Site Preparation Methods* or other habitat installation guides available at: www.xerces.org/pollinator-habitat-installation-guides.

1	Site Preparation Method(s):	<input checked="" type="checkbox"/> Solarization	<input type="checkbox"/> Smother cropping	<input type="checkbox"/> Repeated shallow cultivation	<input type="checkbox"/> Sheet mulching
		<input type="checkbox"/> Soil inversion	<input type="checkbox"/> Organic herbicide applications	<input type="checkbox"/> Sod removal	
2	Planting Method(s):	<input checked="" type="checkbox"/> Broadcasting	<input type="checkbox"/> Drop-seeding	<input type="checkbox"/> Native seed drill	<input type="checkbox"/> Transplants
3	Site Maintenance During Establishment:	<input type="checkbox"/> Mowing	<input type="checkbox"/> Hand-weeding	<input checked="" type="checkbox"/> Spot-spraying	<input checked="" type="checkbox"/> Weed removal around site edges
	for annuals:	<input type="checkbox"/> Seasonal mowing	<input type="checkbox"/> Grass-selective herbicide	<input type="checkbox"/> Irrigation	
	for weed control:	<input type="checkbox"/> Rotational mowing	<input type="checkbox"/> Conservation haying	<input type="checkbox"/> Grazing	
		<input type="checkbox"/> Spot-mowing	<input type="checkbox"/> Prescribed fire		

STEP 3—Plant Selection

Individual species should be chosen to provide consistent and abundant floral resources throughout the year. In order to achieve this goal, at least three species from each blooming period (early, mid, and late season), should be included. The best time for planting most species is in the late fall. NOTE: Transplants may be preferred when seed is not available, weed pressure is high, or when a particular species is difficult to establish by seed. Plugs are usually the most cost-effective container size for transplants.

DESIRABLE SPECIES		IDENTIFYING CHARACTERISTICS				
#	Common or Scientific Name	Description (variety/subspecies, color, etc.)	☼	♂♀	☼ (C) (P) (B)	Y (C) (P) (B)
1	California poppy (<i>Erysimum californicum</i>)	4 petals, carrot-like leaves	A	A	☼☼☼☼	☼☼☼☼
2	Globe gilia (<i>Gilia capitata</i>)	Purple, "ball"-like	A	C	☼☼☼☼	☼☼☼☼
3	Farewell-to-spring (<i>Clarkia amoena</i>)	Pink, looks like a poppy	A	A	☼☼☼☼	☼☼☼☼
4	Western yarrow (<i>Achillea millefolium</i>)	White, feathery leaves	P	C	☼☼☼☼	☼☼☼☼
5	Bigleaf lupine (<i>Lupinus polyphyllus</i>)	Purple, legume, palmate leaves	P	C	☼☼☼☼	☼☼☼☼
6	Oregon sunshine (<i>Eriophyllum lanatum</i>)	Yellow, daisy-like	P	C	☼☼☼☼	☼☼☼☼
7	Douglas aster (<i>Symphotrichum subspicatum</i>)	Purple, daisy-like	P	C	☼☼☼☼	☼☼☼☼
8	Western goldentop (<i>Euthamia occidentalis</i>)	Yellow, small flowers	P	A/C	☼☼☼☼	☼☼☼☼
9	Roemer's fescue (<i>Festuca roemerii</i>)	Cool season bunchgrass	P	R	☼☼☼☼	☼☼☼☼
					☼☼☼☼	☼☼☼☼
					☼☼☼☼	☼☼☼☼
					☼☼☼☼	☼☼☼☼

KEY ✓ ANY ESTABLISHED desirable species not installed or part of the seed mix ☼ LIFE CYCLE: A (annual), B (biennial), P (perennial) ♀♂ ABUNDANCE: A (abundant), C (common), R (rare) - flow performance/early successional ☼ BLOOM TIME: ☼ (early/spring), ☼ (mid/summer), ☼ (late summer/fall) Y FORM: ☼ (forb/wildflower), ☼ (native grass), ☼ (woody tree/shrub)

Print copies of this and other forms at: www.xerces.org/habitat-assessment-guides. See Appendix B for a list of the available forms.

Overlapping Bloom

Many pollinators are only active during a portion of the growing season, while some forage throughout the entire growing season. During their flight periods, pollinators require a steady supply of pollen and nectar. A diverse community of pollinators is therefore best supported by wildflower habitat that contains numerous species with overlapping bloom periods. This is because gaps between bloom periods could force resident pollinators to abandon a site. We define a gap in bloom as a period of time when wildflower bloom is sparse or nonexistent (less than 10% cover of blooming wildflower species) for a two week period. Determining a gap in bloom can vary regionally. For example, wildflowers begin blooming as early as February in California, while bloom begins later in the spring—in March in the South/South Central states and around April/early May in the Midwest and East Coast. Some bloom expectations are consistent across regions: bloom should last until late October (under normal rainfall), when most of the pollinators have ceased activity in all regions.

(< 25%), with no problematic species present. It is also recommended to use the initial seed list to create a Pollinator Habitat Installation Plan (see Appendix B), which can later be used as a point of reference when monitoring and evaluating the habitat (see an example *Pollinator Habitat Installation Plan* on page 3). Ideally native species seeded into the site are well-adapted for the local site and weather conditions, and therefore expected to thrive. If so, then ask the following questions:

- ☞ Are all species planted present?
- ☞ Do wildflowers or weedy species dominate?
- ☞ Is a diversity of species present in each season?
- ☞ Are any problematic weed species present?

If answers to these questions indicate that wildflowers are not diverse and dominant in the habitat site, then management activities are likely necessary. The best way to determine if management activities are needed is through routine monitoring of the wildflower habitat.



Management Process

In order to achieve the best management outcomes for the long term health of wildflower habitat and associated pollinators, we recommend taking an active management approach. Active management involves early identification of potential problems before they become major issues. For example, early detection and management of an incipient invasive weed is much easier than trying to control a large scale invasion. Active management can also help reduce costs, as re-starting a project is often more expensive than maintaining existing habitat. An active approach requires a low-level but consistent time commitment in which the land manager or land owner regularly monitors, evaluates, prescribes, and implements management activities to maintain their wildflower plantings.

Monitoring

It is important to routinely check wildflower habitat to ensure that the species planted are still present and providing abundant blooms. Monitoring at different times throughout the growing season is particularly important because it allows observation of conditions across different seasons and the

FIGURE 3.1: Procedure for Monitoring and Managing Habitat

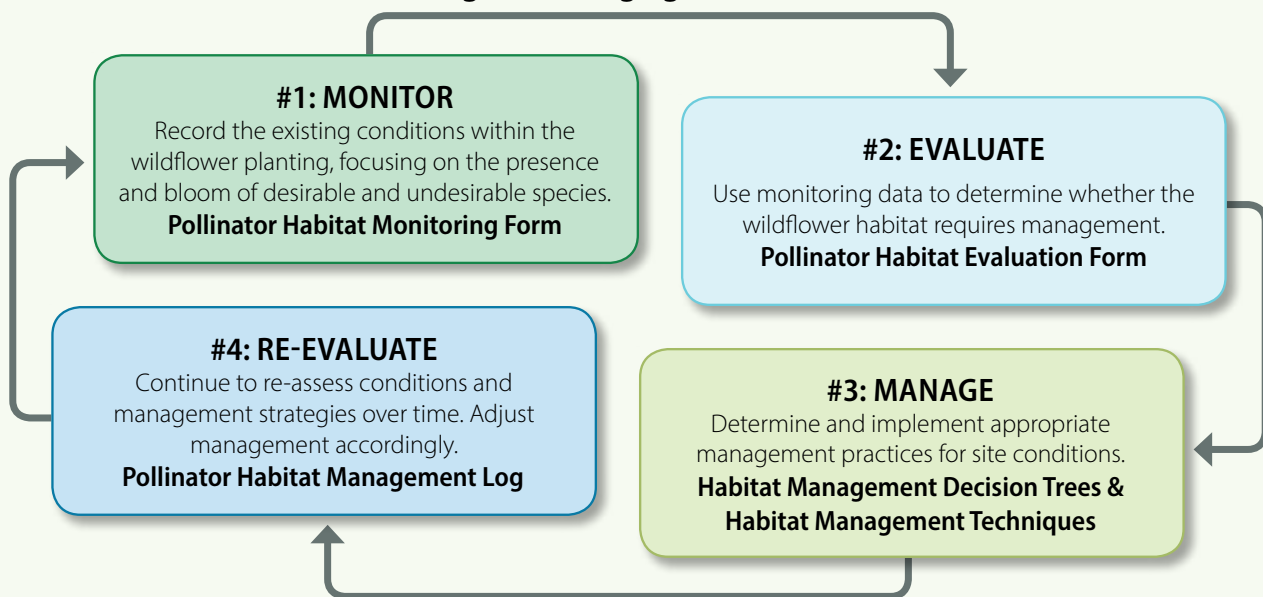

detection of trends that can't be observed without repeat monitoring. For example, monitoring allows land managers to identify gaps in bloom and plan management actions to fill that gap (e.g., interseeding in subsequent years).

We recommend monitoring every 2–4 weeks from spring through fall. The timing and intensity of monitoring varies by region (for more information, see the *Regional Differences Table* on page 43). Many perennial species may not flower in the first year post-planting, while most annual species are early-successional species that disappear over time. Knowing which species should be present (consult the initial seed mix) can help with evaluation of whether the wildflower habitat is performing as expected. Over time, monitoring frequency can decrease, provided it is still possible to ensure that the habitat maintains its desired condition. We do recommend increasing monitoring intensity in the years following severe or unusual weather to ensure the community has not shifted towards undesirable conditions.

A few simple metrics can provide information on the status of the wildflower habitat and whether it is providing sufficient floral resources for pollinators throughout the year. These metrics include:

1. **Presence**—whether a specific species occupies a site, and at what density. We assign four categories that also denote the abundance of the species: Abundant, Common, Rare, Not present.
2. **Plant diversity**—the number of both planted (desired) and unwanted (weedy) species present.

Tracking each wildflower species over time can help to identify species that could potentially dominate the site or those in danger of disappearing. One easy way to do this is to use your original planting mix to keep track of the species planted within the site. It is also a good idea to note the presence and cover of unwanted weedy species to help determine when management is necessary. Use the *Pollinator Habitat Monitoring Form* (see example *Pollinator Habitat Monitoring Form* on pages 7–8) to record all species present. The plant diversity data can help identify if a variety and balance of species are providing pollen and nectar to bees, and will assist in the selection of specific management actions that can maintain conditions that foster wildflower diversity.

FIGURE 3.2: A red clover (*Trifolium pratense*) crop on both sides of the wildflower strip—outlined in white—provides additional food resources for pollinators, but also poses the risk of outcompeting native wildflowers over time. It is important to monitor the presence of red clover in the wildflower planting, evaluate if it is taking over, and prepare management actions to balance the plant community if diversity is a long term goal.





FIGURE 3.4: Wildflower bloom can shift rapidly in a short period of time, which is why it is important to monitor wildflower plantings regularly during the growing season—approximately every 2–4 weeks—in order to document species diversity and abundance over time.

Management

When deciding among management techniques, select practices that maintain the existing diversity while controlling weeds in the habitat. The Pollinator Habitat Decision Trees (pages 31–33) can help identify appropriate management technique for a variety of conditions commonly found in pollinator habitat. The timing of management actions is often critical to their success.

We recommend recording all management actions and outcomes in a *Pollinator Habitat Management Log* (see an example *Pollinator Habitat Management Log* on page 35). Recording information can help guide future management by logging whether a management action achieved the desired results and should be repeated in the future, or whether it needs to be altered in order to generate preferred outcomes.

Setting action thresholds for percent cover of weeds can help land managers determine when to take targeted management actions to reduce an unwanted species. Thresholds often vary by personal preference and by species of concern. For example, for a pernicious weed like musk thistle (*Carduus nutans*), a threshold of 5% cover may motivate management, whereas for a weedy species that is not particularly aggressive and likely to diminish over time—such as yellow foxtail (*Setaria pumila*)—a threshold may be higher, such as 25% cover, before action is warranted.

Re-evaluation

Habitat management is a long-term commitment and requires reassessment and adjustment in order to maximize success. Continued monitoring over time allows flexibility in adapting a management approach when new conditions arise or management actions do not have the intended effect. The data collected by monitoring provides a baseline for comparison of management strategies used (see example *Pollinator Habitat Management Log*, page 35). Repeated monitoring and review of past management actions will highlight potential problems quickly. For example, if targeted weed populations continue to increase, then different and/or more aggressive management is

FIGURE 3.5: This diverse wildflower prairie on an Oklahoma ranch is managed by annual mowing and an occasional prescribed burn to maintain wildflower diversity.



likely required. Remember that each site is different and may respond to techniques in a different way. Adaptive management can help to tailor habitat maintenance to the site's unique conditions.

Figure 3.6: Example Management Strategies Following Habitat Evaluation

Example Low Abundance Species Management

Consider interseeding bigleaf lupine into the site (FIGURE 3.6, #5). California poppy is declining, but because it is an annual, that can be expected and it can be allowed to drop out of the mix (#1). In the case of globe gilia (#2), we would recommend substituting a different species that blooms at the same time of year because it appears to be poorly suited to the site or doesn't compete well. For Douglas aster (#7), a perennial species, we would recommend interseeding and may even advise plug planting if multiple interseedings of Douglas aster are unsuccessful, as it offers great late-season pollen and nectar resources to pollinators and persists for several years.

Example Dominant Species Management

For native species with very high abundance, like western goldentop (FIGURE 3.6, #8), consider mowing a patch before it sets seed in order to reduce its abundance in the following year, providing the opportunity for other wildflowers to establish. It may be advisable to interseed following this management action if other wildflowers that bloom during the same time period are absent or present in very low numbers.

Example Gaps In Bloom

In this example, there are gaps in bloom in mid-March and in late September/ early October. We would recommend interseeding species whose bloom period would overlap the spring gap in bloom and others that help extend the season later in the year. Appropriate species will vary by region. See *Additional Resources* (page 41–42) for links to regional plant lists that can help with species selection.

Example Weed Management

When unwanted species reach a threshold level, in this case over 10% for all weedy species (FIGURE 3.6, circled), they should be aggressively targeted to reduce the potential that take over the site. This form also lets you see when management actions achieve their intended function. For example, management of non-native grasses in Year 3 led to decreased levels in subsequent years.



FIGURE 3.6: Example Pollinator Habitat Evaluation Form *continued*—Unwanted Species

example
STEP 3—Desirable Species Persistence *continued*

NATIVE GRASSES

Native Grass Management—Using the Pollinator Habitat Monitoring Forms, determine whether each native grass species is present year after year, then estimate average abundance throughout the year in order to determine if a species requires management, and circle any species that have reached a threshold amount. Track these species to ensure that their populations remain under the levels you deem acceptable.

DESIRABLE SPECIES		SPECIES ABUNDANCE BY YEAR				
#	Common or Scientific Name	2013	2014	2015	2016	20
1	Roemer's fescue (<i>Festuca roemerii</i>)	R	C	C	R	

STEP 4—Unwanted Species Persistence

Keeping track of the levels of weedy species present will help to decide when management is necessary. We recommend setting a threshold level that weed populations should not exceed. When weeds get to those levels, it should trigger a management action.

WEEDS, NON-NATIVES, INVASIVE SPECIES, ETC.

Weed Management—Using the Pollinator Habitat Monitoring Forms, determine which weedy species are present year after year and which species are Highly Problematic in order to determine if a species requires management. Circle any species that have reached a threshold amount or require immediate action. Track these species to ensure that their populations remain under the levels you deem acceptable. Many weed species are easy to control when their populations are low, but can quickly take over a site, necessitating re-starting when their numbers get too high.

UNWANTED SPECIES			SPECIES ABUNDANCE BY YEAR				
#	Common or Scientific Name	Y ¹ (Check year)	2013	2014	2015	2016	20
1	Himalayan blackberry (<i>Rubus armeniacus</i>)	Y ¹ (A) (B) (C) (D)	R	R	N	R	
2	Bindweed (<i>Convolvulus arvensis</i>)	Y ¹ (A) (B) (C) (D)	R	R	C	R	
3	English plantain (<i>Plantago lanceolata</i>)	Y ¹ (A) (B) (C) (D)	N	R	N	N	
4	Dock/sorrel (<i>Rumex</i> spp.)	Y ¹ (A) (B) (C) (D)	R	R	R	N	
5	Giant foxtail (<i>Setaria faberii</i>)	Y ¹ (A) (B) (C) (D)	R	C	C	R	
6	Wild oat (<i>Avena fatua</i>)	Y ¹ (A) (B) (C) (D)	R	C	C	R	
		Y ¹ (A) (B) (C) (D)					
		Y ¹ (A) (B) (C) (D)					
		Y ¹ (A) (B) (C) (D)					
		Y ¹ (A) (B) (C) (D)					
		Y ¹ (A) (B) (C) (D)					
		Y ¹ (A) (B) (C) (D)					
		Y ¹ (A) (B) (C) (D)					

KEY Y¹ FORM: (A) (B) (C) (D) (E) (F) (G) (H) (I) (J) (K) (L) (M) (N) (O) (P) (Q) (R) (S) (T) (U) (V) (W) (X) (Y) (Z) (Blank)
ABUNDANCE: A (abundant), C (common), R (rare), N (not present)

Notes:

Print copies of this and other forms at: www.xerces.org/habitat-assessment-guides. See Appendix B for a list of the available forms.

Management Strategies

The goal of long-term management is to maintain a high diversity of bloom across seasons, with manageable weed pressure. In order to maximize management effectiveness, it is important to use the appropriate tools, and to schedule management actions to be implemented at a time when they are likely to have the highest impact. Timing of techniques varies by region (see *Regional Differences Table*, page 43), but is often connected to growth stages of unwanted weedy plants, which may change annually given local weather conditions. Paying close attention to the critical time periods when weeds or other dominant species are growing, flowering, and setting seed will help guide the timing of management activities to best control problematic species.

Some management actions can negatively affect some wildlife, including pollinators. For example, mowing or haying during the bloom period of wildflower species can remove needed flowers and may also harm pollinators and other insects nesting and feeding in the habitat. It is best to spread ongoing management across several years, trying not to disturb more than one third of the managed area at any one time. Pollinator plantings are also excellent habitat for ground nesting birds; therefore, management should avoid disturbing nesting birds when possible. Nesting dates generally range from mid-late spring to late summer, depending on the region, and are available from state wildlife agencies or your USDA NRCS field office.

I. MOWING

Mowing is consistently rated as one of the most effective management tools for increasing or maintaining the diversity and density of forbs. Mowing can be also used to control weeds and limit the encroachment of unwanted woody plants. Timing of mow events determines whether mowing is more effective for maintaining wildflower diversity (Section A) or providing weed control (Section B).

FIGURE 4.1: Many desirable perennials are slow-growing and will tolerate mowing—like this gumweed (*Grindelia* sp.) seedling, shown here seven days after a mow event.



FIGURE 4.2: Pollinator habitat can be ideal nesting habitat for ground-nesting birds and other wildlife. In order to avoid disturbing ground-nesting wildlife, management should be timed to avoid nesting dates.



A. Mowing for Diversity

Mowing for diversity can involve: mowing seasonally (i), mowing rotationally across seasons and across different areas of the pollinator habitat (ii), or coupling these two mowing strategies.

i. *Seasonal Mowing*

In many cases a single mow event can help maintain wildflower diversity and persistence. Timing of mowing can be targeted to reduce abundance of a dominant species, or to reduce litter and aid wildflower seed dispersal. To reduce the cover of dominant species (either planted or unwanted), mow when the plant is most vulnerable, during active growth prior to bloom or before seed set. This action can help limit new growth the following year, and create space for other species to grow. A mow event in the fall can help break down senesced stems and leaves, and to spread wildflower seeds. Fall mowing also targets woody species that can invade pollinator habitats. Litter removal can complement mowing by removing build-up of materials that can limit wildflower germination and growth (see *Litter Removal*, sidebar).

Flail mowing is an effective mow method, as it results in small pieces of vegetation which typically break down quickly. Place the mow bar at a high setting (at least 12" above the soil) to avoid disturbing bumble bees that may be nesting in the area. Available equipment can affect mowing frequency, particularly when the goal of mowing is to reduce woody invaders in the habitat area (e.g., mow less frequently if using a brush hog and more frequently if using a weed-eater).

ii. *Rotational Mowing*

Mowing patches of habitat at different times of the year can help maximize diversity within pollinator habitat by favoring different sets of species and reducing dominance of some species. For example, mowing in the early spring can reduce vegetation that would compete with later-blooming wildflowers, potentially increasing germination, growth or flowering of later-blooming species. However, mowing the entire site in the spring could prevent early-blooming species from flowering, leading to a decline in their populations. We therefore recommend mowing only small areas, either in patches or strips, at any given time. This heterogeneous mowing strategy can help prevent gaps in bloom and enhance diversity of flowering species across the site.

Breaking the site into 3–5 segments and rotating mowing regimens through them (at different times of year) can also help bolster diversity. It is important to keep track of the timing of mowing in each area to avoid mowing the same area during the same time period in sequential years. Conversely, if the goal of mowing is to reduce dominance of a species, continue mowing during the time period that has the largest impact on the target species for several years until the target species has significantly decreased.

When mowing does occur before a species is able to bloom, expect varied responses based on the species. In some cases an early mow during a vegetative state can trigger a plant to go into bud, with flowers forming closer to the ground than their normal growth pattern. If this occurs, the plant is still able to set seed and persist in the site. While most perennial wildflowers will recover from a mowing event (particularly if the mow height is above 12"), some may not be able to flower and reseed in the same year of a mowing event and thus will not increase their populations. Some annuals are sensitive to mowing. If mowed before they bloom, many are unable to recover in time to bloom at a later date, and may subsequently disappear from a site.



B. Mowing for Weed Control

Mowing can also be used to manage weedy vegetation growing in pollinator habitat. Establishment mowing, mowing to control weeds regularly during the first one to two years after initial seeding is common in regions where most wildflower species in pollinator habitats are perennials (e.g. Midwest, Northeast, Mid-Atlantic). Beyond establishment, mowing typically targets weedy species prior to seed set. By mowing weeds before they set seed, the weed seed bank can be greatly reduced. This technique is especially effective for eradicating annual weed species. When mowing to control a perennial weed species, mow events may need to occur multiple times during critical plant growth stages to reduce seed set and plant vigor. If an unwanted weed species is distributed throughout the habitat and the best time to target it is during the bloom period of planted wildflower species, we recommend only mowing $\frac{1}{3}$ – $\frac{1}{5}$ of the habitat at any given time or considering a different management strategy for the target weed species.

Mowing for weed control is easiest to implement either when weedy species have grown taller than wildflower species or when weeds only occur in specific areas. For example, in western regions, many cool season weeds grow significantly taller than wildflowers very early in the spring, so a carefully timed high-mow can manage weeds with minimal harm to wildflowers growing underneath. In cases where weeds are not taller than the wildflowers, focusing only on trouble-spots and/or avoiding mowing while wildflowers are blooming is recommended, except in regions where mowing during the first few years of establishment is recommended (see *Regional Differences Table*, page 43).

It is important to be familiar with the characteristics of target weeds. Like wildflowers, some weed species will set seed lower to the ground when mowed and may need to be eradicated through hand-weeding or other management methods. Other weed species—including bindweed (*Convolvulus* spp.) and mugwort (*Artemisia* spp.)—are stimulated by mowing, thus mowing is not advisable as a control method when they are present.

Litter Removal

Litter (undecomposed plant material) can reduce light penetration to the soil and limit the ability of new wildflower seeds to germinate and grow. Litter removal can favor wildflower communities by removing excess nutrients, especially in formerly cropped lands, because many native plant species thrive in nutrient-poor environments. High soil fertility can promote non-native species, especially during the early stages of habitat establishment. Mowing can help facilitate decomposition and reduce litter build up, although additional removal of litter with a rake is sometimes necessary. A hay rake, tedder tractor attachment, or hand rake can help clear the area. Conservation haying (Section VI) is another method that removes excess litter. If significant litter continually occurs in the site, consider a prescribed burn (See Section VII. *Prescribed Fire*).

FIGURE 4.3: Mowing can be an excellent way to encourage wildflower diversity and reduce cool season weeds when timed correctly—as in this site in California, which was mowed in early spring before the perennials had begun blooming.



When mowing non-native grasses, determining whether they are annual or perennial, and warm or cool season can help inform management timing. Target cool season perennials in the early spring and again in the fall if they resume active growth (typically triggered by a moist fall or cooler fall temperatures.). Cool season annuals need to be mowed before they set seed early in the spring. Many cool season annuals are considered winter annuals—they germinate in fall, overwinter as a rosette (low-lying leaves) and flower in the early spring. Mowing should target the flowering stems in the spring.

Warm season annual and perennial forbs can both be targeted in the late spring, with mowing timed before flowering. However, mowing is not particularly effective for eradicating warm season perennial grasses. Repeated mowing will generally favor grasses over forbs, therefore it is generally not an effective standalone method for perennial weed control. Instead, combine mowing with a grass-selective herbicide treatment. We recommend mowing, waiting for regrowth, then spraying the unwanted species.

i. Spot-mowing

When weeds are clumped together, spot mowing may be an option. A weed-eater (a.k.a. string-trimmer, 'weed whacker') is the recommended tool for spot mowing. A tri-blade is most effective at cutting thick stemmed weeds or small woody stems—e.g., invasive thistles or Himalayan blackberry (*Rubus armeniacus*)—while string is best for thin-stemmed weeds like annual grasses and mustard (*Brassica* spp.). Follow all safety guidelines when operating weed-eaters. Time spot-mowing so that unwanted plants are cut back before they set seed. Weed-eaters can also be used to mow around the site edges (Section V).



FIGURE 4.4: Weed-eaters are effective for spot-mowing because they allow users to target small patches of weeds that are mixed in with desirable plants.

FIGURE 4.5: Hand-weeding is often the most effective way to remove weeds without harming desirable species, although it can be time-consuming in large sites.



II. HAND-WEEDING

While hand-weeding can be time consuming, in some cases it is a highly effective, targeted method. It is particularly well-suited for removal of weedy species that occur in low numbers or are scattered throughout a site. Hand-weeding is often the least invasive way to remove weedy species.

Numerous tools can facilitate hand-weeding, from hoes and hula hoes, to pick axes and pulaskis, to shovels and trowels. We



recommend wearing gloves and long sleeves to protect from spiny plants and sap from plants in the carrot family which cause skin irritations. Weeds are often best targeted during active growth stages, before they have flowered and set seed. If the plant only flowers once in its lifetime and flowering already occurred you don't need to remove the entire plant, instead clip off the seed heads and leave the roots in place. Be aware that some weed seeds—like musk thistle (*Carduus nutans*)—are viable almost as soon as the plant has bolted. These weeds will need to be bagged and removed from a site if they have been allowed to flower.

For perennial and rhizomatous species, make sure to remove as much of the root material as possible, as they can quickly resprout from small root fragments. Weeding when there is some moisture in the soil can make it easier to remove the entire root structure. However, heavily saturated soils can be easily disturbed by hand-weeding, leaving areas for new weeds to recolonize. If weed removal results in large bare patches, consider interseeding the gaps to avoid re-colonization by unwanted species.

III. SPOT-SPRAYING

Spot-spraying refers to the targeted application of herbicide on specific weedy species. The goal is to minimize non-target application and drift to adjacent wildflower species. Backpack sprayers or rope-wick applicators are the most commonly used spot-spraying tools. Spot-spraying can also result in bare patches; we recommend interseeding into large areas that were sprayed after the herbicide residues have dissipated. Information on residual periods of herbicide residue can usually be found on the product label.

It is important to follow the instructions on the label when applying herbicides. Most weedy species should be targeted during their active growth phase. We do not recommend using herbicides on weeds when they are in bloom, because weeds are least susceptible to herbicides during the flowering stage and because such spraying could expose pollinators to harmful chemicals. In addition, avoid any herbicide that is toxic to bees (e.g., paraquat and gramoxone). Sources of information about herbicide toxicity to pollinators are listed in the *Additional Resources* at the end of this document. Guidance on active ingredients that target non-native or invasive weeds and appropriate application timing is usually available from statewide Invasive Plant Councils (e.g., California Invasive Plant Council) or extension agencies. Certified Crop Advisors can also provide assistance with application rates and timing.

FIGURE 4.6: Many conservation programs spot-spray invasive or noxious weeds to avoid disturbing adjacent established native plants—like the Glacier Exotic Plant Team is targeting Canadian thistle and bindweed while avoiding milkweed and globemallow (left), or herbicides are applied as added insurance against invasive woody species in northern tallgrass prairie restoration (right).



IV. GRASS-SELECTIVE HERBICIDE

If non-native grasses are a major weed threat, then grass-selective herbicide may be an appropriate treatment option. Grass-selective herbicide treatments are most effective during the early plant growth phase—not during flowering—when grasses are small (typically <6" tall). It is often necessary to spray multiple times throughout the year to target both warm and cool season grass species. Be aware that grass-selective herbicides can damage forbs if they are applied at high rates or applied multiple times over a short period. Most forbs are able to recover, but may show signs of herbicide damage. If well-established native bunch grasses are present, grass-selective herbicides can still be used, as vigorous perennial native bunch grasses often recover from a single herbicide treatment. However, recently planted native grasses can be eradicated by the use of grass-selective herbicides. If non-native grasses are known to be a major issue at the site, consider seeding only forbs in the initial planting to allow the use of grass-selective herbicides. Native grasses can be interseeded in the future following successful grass-selective herbicide treatment. Be aware that some grass-weeds—like annual ryegrass, (*Lolium multiflorum*)—appear to be resistant to grass-selective herbicides; other removal strategies will be required when targeting those species. Make sure to follow all directions on the label when applying herbicides.

V. WEED REMOVAL AROUND SITE EDGES

When site preparation has been successful, weeds within pollinator habitat may be minimal, but weeds surrounding it could invade from the edges. To combat weeds around pollinator habitat we recommend managing site perimeters through mowing, herbicide application, mulching (best for smaller sites), or a buffer of native bunch grasses. It is likely that weed management will need to occur multiple times throughout the year to target weeds present in different seasons. When mowing outside the site, set the mower bar to the lowest level without it touching the ground. Time mowing to just before or immediately after flowering of unwanted forbs; annual grasses should be mowed prior to seed production. Perennial grasses can be regularly mowed throughout the year to prevent seed production, limit their spread, and reduce their vigor. If there are low-growing or creeping invasive plants on the edge—such as birdsfoot trefoil (*Lotus corniculatus*)—we do not recommend mowing. Instead, hand weeding or spot spraying may be appropriate.

If spraying herbicides to control weeds in the perimeter of a habitat area, take special care to ensure that herbicides do not drift off target and kill wildflowers. In addition, do not spray any weeds

FIGURE 4.7: Established sites may need weed management around the edges—outlined in white below—where undesirable plants can be removed by mowing or targeted herbicide applications.



that are in bloom, as this poses a risk to pollinators. If combating nearby weeds with herbicides, consider a long term strategy such as expanding the existing habitat to encompass the problem areas, if the adjacent area contains suitable conditions for wildflowers (e.g., flat terrain that is not frequently driven over). If mulching the borders of a planting, apply weed-free mulch (e.g., straw or wood chips) on an annual basis. If weeds penetrate the barrier, hand-weeding or herbicide applications may be needed. Another option is to plant a buffer of native bunch grasses around wildflower habitat that can be mowed or weeded regularly to help resist weed invasion from the outside edges. If space permits, mulch can also be applied around the native grass border to extend the width of the buffer around the habitat area.

VI. CONSERVATION HAYING

Like mowing and other disturbance regimes, conservation haying is an important management tool for enhancing plant diversity and suppressing the growth/encroachment of woody vegetation in a prairie setting. Conservation haying also reduces light competition from tall grasses, allowing spring blooming flowers and other shorter-statured plants to thrive. Haying differs from mowing in that the resulting litter is removed from the site. As such, haying can be even more effective than mowing at promoting wildflowers because excess nutrients are removed, promoting soils that favor desired plant communities in place of weeds. Moreover, haying can provide direct economic value from pollinator habitat, since the cut and dried herbage can be sold or used as livestock forage, bedding, or mulch.

While haying can benefit plant communities, it can also pose risks to pollinators and other wildlife by abruptly removing flowers at a site. Careful consideration of scale, technique, and timing can help protect pollinators from these impacts. Mow in strips or patches, instead of haying an entire site, to leave refuges for pollinators. Another common method is to divide an area in thirds and cut only one third each year, rotating the cut area annually, such that each parcel is cut every three years. Cutting should occur at reduced speeds (less than 8 mph) during daylight in order to give pollinators and other wildlife more time to disperse. Use of a flushing-bar on the mower may also help minimize risk to pollinators. Set the mower blades at a high height (12–16") in order to maximize the vegetative structure (nesting/ overwintering habitat) that is left on site.

Cutting late in the summer or fall (after peak bloom) is recommended for pollinators, since cutting



FIGURE 4.8: Conservation haying reduces light competition from tall grasses by allowing spring-blooming flowers and other short-statured plants to thrive, and it may also help bees to more easily find these resources. Above, a strip of spring-blooming wildflowers is no different from the surrounding area except that it was hayed in the previous fall. The 85 ac site in Minnesota below shows conservation haying on a larger scale—a mosaic of 5–10 ac hayed and unhayed treatment plots has been established, such that only a portion of the site is hayed in any given year.



at this time can minimize sudden reductions in nectar and pollen resources, and also ensures that most plants have set and dropped seed. However, if hay is to be harvested for livestock forage, these objectives may need to be balanced with the protein content and other nutritional qualities of the hay. Note that some wildflower species like wild buckwheat (*Eriogonum* spp.) and buttercups (*Ranunculus* spp.), and some weedy species like hemlock (*Conium maculatum*) and St. John's wort (*Hypericum* spp.) may be toxic to livestock. If conservation haying is planned, do not plant toxic species and make sure that toxic weeds are adequately treated before haying or are not present. Consider occasionally interseeding additional desirable native grasses and forbs into the site by broadcast seeding the area immediately after haying if the soil surface is visible. This will help mitigate the loss of natural seed drop by wildflowers that are cut during the haying process.

VII. PRESCRIBED FIRE

Prescribed fire can be used to manage pollinator habitat. Fire is a natural component of many native plant communities, particularly those with native grasses that can carry fire. Fire can be used for many purposes: to reduce litter, suppress woody species, release nutrients, open space for new growth, stimulate germination of some seeds, enhance flowering, and reduce weedy competition. Fire can be an effective tool for combating invasive plants while invigorating growth of native species, particularly when compared with strip disking, herbicide, or hand-pulling. The value of prescribed fire, however, depends on specific site conditions, timing of burn, and plant community composition. For example, a few invasive species can benefit from fire or carry a hotter, more damaging fire than the native plant community; therefore, fire should be avoided when these kinds of species are present—examples include cogongrass (*Imperata cylindrica*), cheatgrass (*Bromus tectorum*), and Chinese bushclover/ sericea lespedeza (*Lespedeza cuneata*).

The timing of a prescribed burn influences its impact on the plant community. For example, burning during the late winter season can stimulate cool-season grasses and spring wildflowers. Spring burns tend to suppress cool-season grasses and invigorate warm-season grasses, while summer fires are most efficient at controlling woody species, such as red cedar (*Juniperus virginiana*). Fall burns can stimulate wildflowers the following growing season.

Many pollinators are vulnerable to the effects of fire. We recommend splitting the site into three to five sections, with the aim of burning one section per year. This ensures refuge for wildlife and supports quicker recolonization of previously burned areas. Refuge from fire also helps sustain healthy populations of pollinators and natural enemies of crop pests close to crop fields.

FIGURE 4.9: Prescribed fire can be highly effective for managing native plant populations to favor wildflowers over aggressive grasses and woody species—here the Michigan Department of Natural Resources and The Nature Conservancy conduct an annual burn to preserve habitat for the endangered Karner blue butterfly (*Plebejus melissa samuelis*).



Prescribed burns should be conducted by a trained professional. Before using prescribed fire, consult with local forestry or natural resources departments to find out if state permits or training are required. Always include fire breaks—paths cleared of leaves or other dry plant material to expose green vegetation, bare soil, rock, or bodies of water—when using prescribed fire. If fire is planned as an ongoing management technique, include fire breaks in the planting and management design process by incorporating clovers, cool season grasses, or other plant groups along the edges of the habitat. These plant groups are green (less flammable) from spring through fall, during which most burns take place.

VIII. GRAZING

Selective grazing can be used to help suppress dominant grasses (native and non-native) and maintain wildflowers in pollinator habitat; however, improperly managed grazing also can reduce or eliminate wildflower cover. Grazing may not be right for every site; for example, balancing grazing requirements and appropriate stocking rates on small sites can be difficult, and sites with unprotected waterways or many steep slopes may be unsuitable for grazing. A light to moderate stocking rate—depending on the site—helps ensure that livestock are primarily eating grasses and not overgrazing a site. Consider the duration of grazing period when planning for an appropriate stocking rate that favors pollinator plants; grazers will consume more forage and become less selective the longer they are kept in an area. Avoid overgrazing, as an overgrazed pasture is vulnerable to weed incursion. If an area is accidentally overgrazed, it may require interseeding to restore any wildflower species consumed by grazers.

Timing of grazing can help address different site conditions. For example, to reduce the dominance of cool-season grasses, graze in early spring (before warm-season grasses are active) or in the fall (after warm-season grasses have set seed). To combat warm-season grasses, graze in late spring or early summer. Whether controlling either warm- or cool-season grasses, try to graze unwanted grasses especially hard during their active growth stage prior to bloom. If the overall goal is to increase wildflower biodiversity without targeting a specific non-native grass species, use adaptive management with light to moderate stocking rates.

Before choosing grazing as a management strategy, it is important to check the palatability of the species in your planting. If the wildflowers you want to promote are highly or moderately palatable, grazing may not be the most appropriate tool to increase their abundance. We also recommend determining whether any plants in the area to be grazed are toxic to livestock before deciding whether grazing is an appropriate technique (see *Additional Resources: Grazing*).

Cattle or bison are the preferred grazing livestock in pollinator habitat dominated by grasses

FIGURE 4.10: Cattle grazing around various native wildflowers—including boneset (*Eupatorium* spp.) and blue lobelia (*Lobelia siphilitica*).



FIGURE 4.11: When properly managed at a low stocking rate, cattle grazing is a highly efficient method for reducing grasses from pollinator habitat.



because, at low stocking rates, they generally prefer grasses over wildflowers. However, cattle especially find many wildflower species highly palatable—such as prairie clover (*Dalea* spp.). If your habitat has high wildflower density, cattle grazing may not be the preferred management tool to maintain diversity. Goats and sheep are less selective grazers and will consume both wanted and unwanted species; they are therefore less preferred grazers for pollinator plantings but may be used to graze for weed or brush control.

A. Rotational Grazing

There are many rotational grazing systems. When designing a rotational grazing system that will benefit pollinators, maintaining stocking rates and rest periods that allow wildflowers to bloom throughout the growing season is essential. Consider splitting the site into three to five segments that are grazed at different times and with varied intensity and duration across years. Create patchy vegetation structure by maintaining grazed areas, areas that are recovering from grazing, and refuge areas free from grazing for an entire season to provide a variety of habitats for pollinators and other invertebrates.

B. Patch-Burn Grazing

One method to utilize both prescribed fire and grazing is patch-burn grazing. Typically, $\frac{1}{3}$ to $\frac{1}{5}$ of the site is burned each year and no interior fencing is used to direct grazing. With a light to moderate stocking rate, this results in heavy grazing pressure in the most recently burned area, some grazing in areas burned the previous year and very little grazing pressure in areas burned two or more years ago. This variance in grazing pressure creates areas of differing vegetation height, litter cover, and bare ground on the same management site. Patch-burn grazing can increase abundance of any unpalatable wildflowers as livestock preferentially consume new growth. If livestock are grazing the most recently burned site to a uniform short height (there are not taller wildflowers standing among short grazed grasses), consider decreasing the stocking rate for the entire pasture.

C. Grazing for Broadleaf Weed Control

Grazing can be an effective tool to remove some populations of broadleaf invasive weeds. For example, goats are increasingly being used in the Midwest to manage invasive buckthorn (*Rhamnus* spp.) shrubs, as well as Canada goldenrod (*Solidago canadensis*), a native wildflower that often dominates wildflower plantings and can require management to set it back so that other species can thrive. Typically, areas with a high density of weedy species are fenced in and grazed intensely when the weed species is vulnerable (actively growing). Preventing weed seed set is important and multiple years of control or stacking methods of control (e.g., grazing followed by herbicide) may be necessary to exhaust the existing seed bank and to adequately eliminate perennial weeds in an area. Interseeding areas of previous dense weed populations may be necessary after control.

IX. REINTRODUCING WILDFLOWER DIVERSITY

A. Interseeding

Interseeding is the addition of seeds to a site while maintaining some or all of the existing vegetation. It is used to restore species that have been lost from the site, or introduce new species not originally



included. Interseeding can address the following issues: restore wildflowers to a grass dominant site, fill a gap in bloom, add a critical species (e.g., milkweed that support monarchs), or provide a seed bank to fill in after weed eradication leads to exposed or disturbed patches of soil.

In many landscapes, suppression of dominant vegetation and litter removal is necessary before interseeding. Grazing, mowing, haying, prescribed burning, chemical control, or a combination of these techniques prior to interseeding and again after interseeding, can maximize wildflower establishment and persistence. Time the vegetation suppression techniques to stress the dominant vegetation at its most vulnerable stage (i.e., actively growing and at, or near, flowering). For example, a site dominated by cool-season grasses should be disturbed in the spring and fall before a dormant interseeding and ongoing management should continue to emphasize disturbance during those periods.

Species selection for interseeding depends on the existing plant community. If the existing vegetation is missing one or multiple plant guilds typical of a healthy plant community in the region (e.g., warm- and cool-season grasses, sedges, wildflowers), aim to restore those guilds through interseeding. Native species that are easily established and will persist are the best choice for interseeding. Interseeding rates should be 25% higher than accepted seeding rates for restorations in the region. Many wildflower species require a period of cold and moist conditions to break dormancy and the best timing for interseeding is before or during periods of regional precipitation (e.g., during the monsoon season in the southwest or during the winter dormant season in the west). If the climate permits, snow seeding is another option (see *Snow Seeding*, sidebar). If site preparation has suppressed existing vegetation and removed litter, broadcast interseeding followed by rolling with a cultipacker is an effective approach. If some litter remains, or broadcast seeding isn't appropriate, an accurately calibrated and carefully operated native seed drill (planting no deeper than ¼") can also be used for interseeding.

In the first growing season following interseeding, new seedlings will emerge in and

Snow Seeding

Snow seeding is an option for interseeding during the dormant season in cold climates. Because seed is broadcast on top of snow, it is easy to see seed coverage and achieve even distribution of seed across the site (FIGURE 4.12A). A light cover of snow of just a few inches is preferred to heavy snow since the seed must work its way through the snow to reach the soil. Before snow-seeding, check the weather to make sure that heavy rains are not expected in the near future—since rain or rapid snow melting could cause the seed to wash around (or off) the site before it has found its way to the soil. Snow seeding can be done by hand, with a belly crank, or a broadcaster (FIGURE 4.12B).

FIGURE 4.12A: Seed Distribution on Snow



FIGURE 4.12B: Broadcasting Seed on Snow





FIGURE 4.13: This California pollinator meadow features numerous native wildflower species with overlapping bloom times to support pollinators throughout the growing season. In order to maintain a diversity of bloom over time, the site was mowed and interseeded with additional high quality wildflowers in November 2015

amongst existing vegetation. This highly competitive environment can limit seedling establishment. Management to reduce this competition can promote the establishment of newly interseeded species. If established wildflower species won't be harmed, mowing vegetation to a height of 4–6" can increase sunlight to the seedlings and increase their success rates. If the existing vegetation is composed mostly of grasses (whether native or non-native), multiple cuts above the height of the seedlings will likely be needed.

B. Plug or Bare Root Planting

In small areas or in small, unique habitat areas (e.g., a wet slough among a larger grassland site), using plugs or bare roots plants to increase diversity is an option. Some plant species don't germinate reliably from seed in field settings when planted in a seed mix—such as vinegar weed (*Trichostema lanceolatum*). Other species have a better chance of survival when they are planted from a container than when planted from seed—such as some milkweed species (e.g., *Asclepias sullivantii*) or some blazing star species (e.g., *Liatis spicata*). Using transplants provides these difficult-to-establish species an opportunity to develop a strong root structure and compete with other species in diverse systems. Plugs are often the smallest size container available, making them the most affordable option. In arid climates, plugs are best planted in the fall with the rains; in other regions, they can be planted during the growing season, timed with rains, such as spring or fall (see *Regional Differences Table*, page 43). Avoid transplanting in summer during periods of extreme heat as this can lead to plant stress and limit successful establishment. It may be necessary to water for one to two years after planting plugs, depending on precipitation in your region.

X. IRRIGATION

We recommend planting native, locally adapted species that are drought-tolerant. Nevertheless, when areas experience severe drought, water scarcity can decrease the survival and establishment of drought-adapted species. Providing just enough water to mimic 'normal' rainfall patterns (i.e., winter in California, monsoons in the southwest) during drought years can greatly improve wildflower germination and persistence. Irrigation is most critical in drought-prone regions during the initial



establishment phase (typically one to three years); however, supplemental irrigation can be necessary during multi-year droughts. Even in non-drought years, occasional summer irrigation can also be used to prolong the bloom period into late summer and fall in arid regions.

When repeated irrigation is anticipated, it can be practical to install an irrigation system. The most efficient and easily installed irrigation systems for pollinator habitat are drip irrigation with in-line emitters or micro-sprinklers. Drip-tubing with in-line emitters on 1' centers can be used and laid approximately 2' apart, so that 1' of dripline will soak about 2 ft². Micro-sprinklers need to be mounted on tall risers (3' or more, depending on height of wildflowers being planted). Adequate water-pressure is essential if micro-sprinklers are to be used, and maximum circumference will vary with nozzle design and water pressure. It is also possible to use overhead impact sprinklers on risers instead of micro-sprinklers.

Watering in the evening or at night will minimize evaporation regardless of irrigation method, but is particularly important if using micro-sprinklers. Water every 2–4 weeks, depending on heat and soil moisture conditions.

It is helpful if there is an existing irrigation system to hook into. Because wildflowers need significantly less water than most crops and will often die if over-watered, a separate line and shut-off for the habitat areas is necessary. A remote water timer can be programmed for the habitat area. Dripline conversion materials will be needed if hooking into most agricultural irrigation systems. If there is no existing system, water trucks can be used to irrigate as-needed. However, fine nozzles will be necessary to protect seeds and small seedlings from the force of the water.

XI. STARTING OVER

Hopefully following the advice in this guide will help to avoid situations in which starting over is necessary. In some cases, such as when initial weed control at a site was inadequate, restarting the project by implementing intensive, non-selective weed control might be the best solution. If re-starting, it is a good



FIGURE 4.14: Installing drip-tube irrigation to help establish plant plugs, which benefit from supplemental irrigation during establishment, in a Minnesota pollinator planting.

FIGURE 4.15: In some areas, such as California, irrigation may be necessary to establish new wildflower plantings from seed and should be included in the planning and installation phases of a project.



idea to complete a year of weed control prior to seeding, to control the major issues that led to the need to start over. We recommend initiating site preparation by May (at the latest) the year of intended re-planting. One growing season of intensive weed management using techniques such as chemical fallow or solarization is usually sufficient. If the mix is high in wildflowers that require stratification, then planting in the fall or winter (after October 15th) is generally more successful than a spring planting. For guidance on weed control prior to establishment of pollinator habitat, as well as habitat installation recommendations, see the Xerces Society/NRCS series of establishment guides (see *Additional Resources: Re-starting Habitat*).

If some wildflower species are thriving, consider saving their seeds the year prior to re-starting a project to reduce the cost of seeds when replanting. Different species need to be harvested at different times, and usually require cleaning prior to storing. Make sure to store them in a cool, dry place. Adding silica packets can help prevent buildup of excess moisture. Some seeds respond best to stratification, or storage in a cold environment, such as a fridge. If new seeds are purchased, they can be sown in fall prior to frosts, which provide natural stratification. Seed mixes with high percentages of seeds requiring stratification that are seeded in spring tend to perform less well than if seeded in fall, unless they are placed in cold storage before sowing. For information on seed saving, cleaning and storage, we recommend reviewing regionally available guides (see *Additional Resources: Seed Saving*).

XII. EXTREME WEATHER CONDITIONS

Extreme weather, including droughts and flooding, is becoming more prevalent. Extreme weather can test the ability of even the most proactive manager to maintain wildflower diversity and abundance within a site. We recommend increasing monitoring frequency in the years following an extreme event in order to track and manage novel undesirable conditions.

In multi-year droughts, seeds may lie dormant and their viability may be reduced over time (See *Section X. Irrigation*). Floods can scour a site, removing seed from the seed bank. When floods occur, it might be necessary to add seeds or plugs in subsequent years (See *IX. Reintroducing Wildflower Diversity*). Floods can also introduce seeds of weedy species, thus monitoring for new weedy species after a flood can help prevent new problems. If seasonal flooding is known to be a common occurrence, including flood-tolerant species in the initial seed mix can help habitat withstand inundated conditions. Installing erosion/ scour resistant materials over the seed bed can help retain seeds if flooding becomes a frequent occurrence.

While none of the sites we have worked on have been affected by wildfire, fires are becoming increasingly common, particularly in the arid west. As described above, fire can facilitate the germination of wildflowers. In the case of severe fire, however, it is important to monitor in the following year to observe changes in site conditions. Re-seeding or adopting different management techniques to address altered conditions may be necessary following a burn.

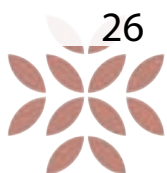

Deciding Which Management Technique to Use

Identifying Conditions

Data collected from routine monitoring will help to identify the conditions present in the pollinator habitat. See Table 5.1 for a list of the most common conditions we've observed in native wildflower meadows. Decision Trees 1–3 provide additional assistance for identifying the condition of your meadow and determining which management techniques to use over time. After initial establishment, planted pollinator habitat often follows one of these common trajectories:

High Diversity of Bloom

The goal of a pollinator habitat planting is a diversity of bloom across seasons with minimal/manageable weed pressure. Some plantings maintain their intended function and plant community structure without much intervention, while others may lose one or many species. Species losses can create gaps in bloom that need to be filled in order to attract and maintain pollinators throughout their foraging season, which can last 4–6 weeks for solitary species with a single generation and many consecutive months for social species or species with multiple generations per growing season. A less frequent condition occurs when one or a few desirable plants grow to dominate the habitat, such as native bunch grasses or a vigorous wildflower species, such as goldenrod (*Solidago* spp.). These dominant plant species will compete with other native species and can eventually prevent the habitat from supporting a diverse

Figure 5.1: This pollinator habitat in Virginia provides late-season bloom through the inclusion of long-blooming wildflowers, such as blanketflower (*Gaillardia* spp.) and black-eyed Susan (*Rudbeckia hirta*).





Figure 5.2: Weedy radish (*Raphanus* spp.), prickly lettuce (*Lactuca serriola*), and mallow (*Malva* spp.) are intermixed with desirable native wildflowers like lupine (*Lupinus* spp.) and baby blue eyes (*Nemophila menziesii*) in this pollinator planting, requiring targeted weed management.

array of flowering plants, as well as their associated pollinators. If vigorous native plants dominate the habitat, light management may facilitate conditions that foster a high diversity of native wildflower species.

Mixture of Desirable and Unwanted Plants

In some circumstances, unwanted species may co-exist with desirable planted species as a patchwork, with weeds dominating in some areas and wildflowers in others. Alternately, weeds may be intermixed with desirable species. These scenarios present different management challenges. In plantings with patchy areas, it is possible to manage weeds intensively without worrying about damaging adjacent wildflowers (i.e., spot-mowing). Interseeding with additional wildflower species is often necessary, however, to fill in the disturbed area after management and repel new unwanted species from taking hold. In plantings where weeds and wildflowers are interspersed, more targeted weed management (e.g., hand-weeding or spot-spraying) is often best.

Defining a Diversity of Bloom

A Diversity of Bloom is defined by overlapping bloom periods of at least 2–3 species during each season (spring, summer, and fall). The goal of long-term management strategies is a Diversity of Bloom across seasons with minimal/manageable weed pressure (see Decision Trees 1–3 on pages 31–33). We define dominance as the condition when one class of species (wildflowers or weeds) are more abundant than the other, with the consequence that they can potentially suppress the other.

FIGURE 5.3: This wildflower field border in California demonstrates a high diversity of bloom with numerous native wildflower species that have overlapping bloom times throughout the growing season.



TABLE 5.1: Common Site Conditions

DOMINANT SPECIES		DESCRIPTION		EXAMPLES [†]
DESIRABLE SPECIES Native wildflower and grass species cover at least 75% of the site	Diverse wildflower bloom with minimal weed cover	Diversity of Bloom		At least three wildflower species in bloom in each season (except winter), with overlapping flowering periods
	Lacking one or more key species	Key planted species missing		One or more planted species did not germinate or failed to establish at site
		Gap(s) in bloom		Lacks early or late-blooming species
	Dominated by one or a few native species	Native grass		Native fescue (<i>Festuca</i> spp.) dominates
		High value pollinator plants		Goldenrod (<i>Solidago</i> spp.) dominates
Low-moderate value pollinator plants		Yarrow (<i>Achillea millefolium</i>) dominates		
MIXTURE Both weeds and wildflowers present	Weeds are present in significant amounts in some—but not all—areas of the site	Intermixed	» Mostly Woody	Weedy trees/shrubs are interspersed in both well-established and poorly-established areas
			» Mostly Forbs	Flowering weeds are interspersed in both well-established and poorly-established areas
			» Mostly Grasses	Weedy grass(es) are interspersed in both well-established and poorly-established areas
	Patches		Distinct patches where weeds dominate and distinct areas where wildflowers dominated	
UNWANTED SPECIES Weeds—including non-native, invasive, and noxious species—cover 70% or more of the site	Dominated by one or a few weed types or species with few to no native species	Grass(es)	» Warm-Season	Cheat grass (<i>Bromus tectorum</i>)
			» Cool season Annual	Medusahead (<i>Taeniatherum caput-medusae</i>)
			» Cool season Perennial	Harding grass (<i>Phalaris aquatica</i>)
	Forbs		Bindweed (<i>Convolvulus</i> spp.); Russian thistle (<i>Salsola tragus</i> /S. kali)	
	Woody plants		Blackberry (<i>Rubus</i> spp.); Eastern redcedar (<i>Juniperus virginiana</i>)	
More than one form of weedy species present		Mixture		May include mixed weedy grasses, forbs, and woody species

TABLE 5.1 Notes:

† These are just a few representative examples of different native and weedy species—contact your local extension office for examples specific to your region.





Figure 5.4: A large patch of yellow star thistle (*Centaurea solstitialis*)—outlined in red—is pushing out native wildflowers that include gumweed (*Grindelia* spp.) and California poppies (*Eschscholzia californica*), allowing for intensive management practices like spot-mowing.

When to Use Interseeding

Interseeding is a tool that can help restore diversity lost from a site (see *Management Strategies: Interseeding*). It often is most successful when coupled with other forms of weed management, particularly if management is targeted at reducing abundance of dominant wildflowers or weeds and results in large areas of bare soil that could be colonized by unwanted species. Interseeding can be costly and may not always be necessary. We recommend waiting to determine whether management actions alone stimulate the habitat to move closer to the desirable conditions. If not, consider interseeding after completing other management actions in future years.

Dominated by Undesirable Species

Even a habitat that starts off with a robust wildflower population may succumb to weed invasion over time. On the one hand, weeds might co-exist with wildflowers, necessitating some light management. However, when one or many weeds species takes over, a more intensive approach is required.

Selecting Management Treatment

Once the condition of the planting has been identified (e.g., see Table 5.1), determine the appropriate management technique(s). We provide decision trees to facilitate this process (p. 31–33). A number of different management techniques can be utilized to address one or more conditions. We recommend trying first using familiar, known techniques, prioritizing those that also have the least negative impact on wildflowers.

Timing of implementation of a management technique is critical to its success. For example, mowing after seed set by a weedy species provides little weed control and may even exacerbate the invasion by distributing seeds throughout the site. Careful timing of a management action can help achieve different goals. For example, mowing in the spring can target many weeds (e.g., cool season grasses) during their active growth stage, whereas mowing in the fall targets late-flowering weeds that produce seeds in the fall. Late season mowing is also a good option for control of woody species. While many management strategies are effective throughout the U.S., implementation timing varies by region. For this reason, we recommend monitoring to ensure that actions occur during the optimal window.



DECISION TREE #1: Sites Dominated by Desirable Species

The goal of long-term management strategies is to foster or maintain a DIVERSITY OF BLOOM across seasons with minimal/manageable weed pressure (see *Notes* below). We define dominance as the condition when one or more species (wildflowers or weeds) are more abundant than the others, with the consequence that species diversity may be suppressed.

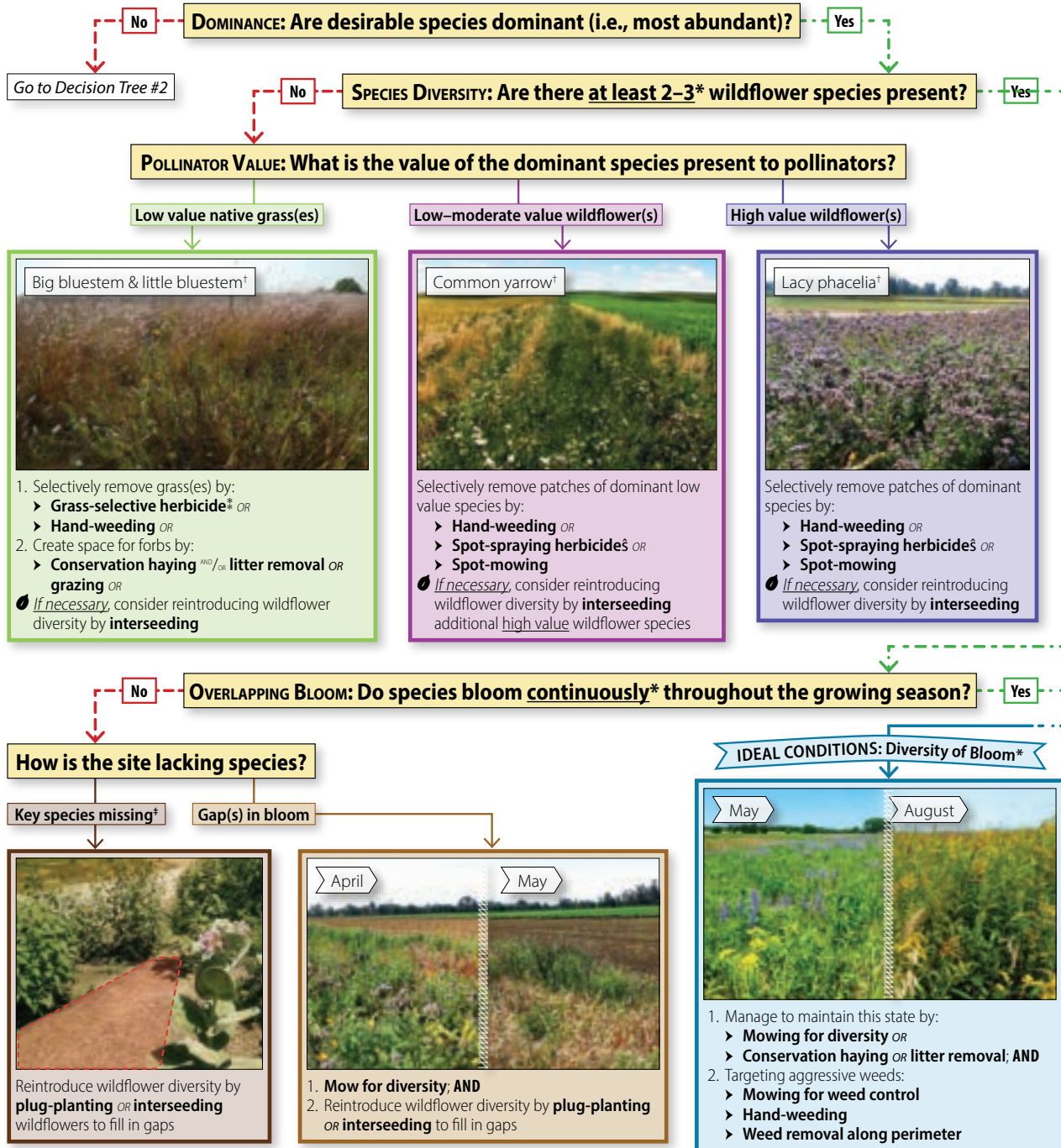

DECISION TREE #1 Notes:

- * A DIVERSITY OF BLOOM is defined by overlapping bloom periods of at least 2–3 species during each season (spring, summer, and fall).
- * During active growth phase.
- † These are representative examples of native species—contact your local extension office for examples specific to your region.
- ‡ Some species don't establish well from seed and may require transplants.
- ☛ See *When to Use Interseeding*, p. 30.

DECISION TREE #2: Sites with a Mixture of Desirable & Unwanted Species

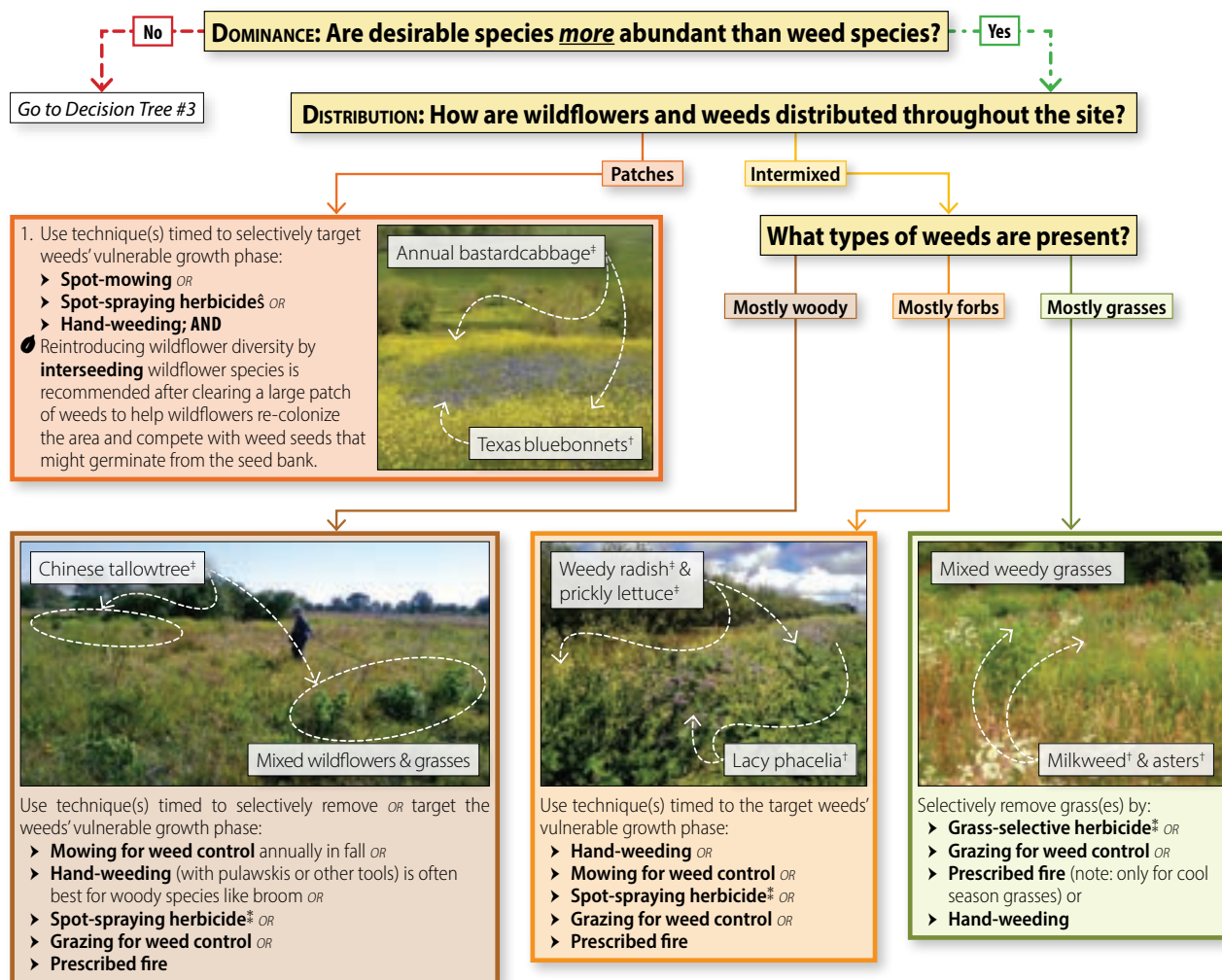

DECISION TREES #2 & 3 Notes:

- * During active growth phase. Targeting weeds during the vulnerable stage is critical. This can include using control methods during the flowering of a monocarpic plant, spraying a perennial during phloem flow to the roots in the fall, etc. For more information on successfully targeting weedy species in your area, contact your local extension office.
- † These are representative examples of native species—contact your local extension office for examples specific to your region.
- ‡ These are common widespread non-native weedy species—contact your local extension office for examples specific to your region.
- ☛ Interseeding wildflower species is recommended after clearing a large patch of weeds to help wildflowers re-colonize the area and compete with weed seeds that might germinate from the seed bank. See *When to Use Interseeding* on p. 30 for details.
- △ Note: Sites with high weed pressure—like the one pictured—will likely need multi-years of management before interseeding.
- ① Sandbar willow (*Salix exigua*) is a desirable species for streambank stabilization *in its native range*, but can become weedy without proper management.



DECISION TREE #3: Sites Dominated by Unwanted Species

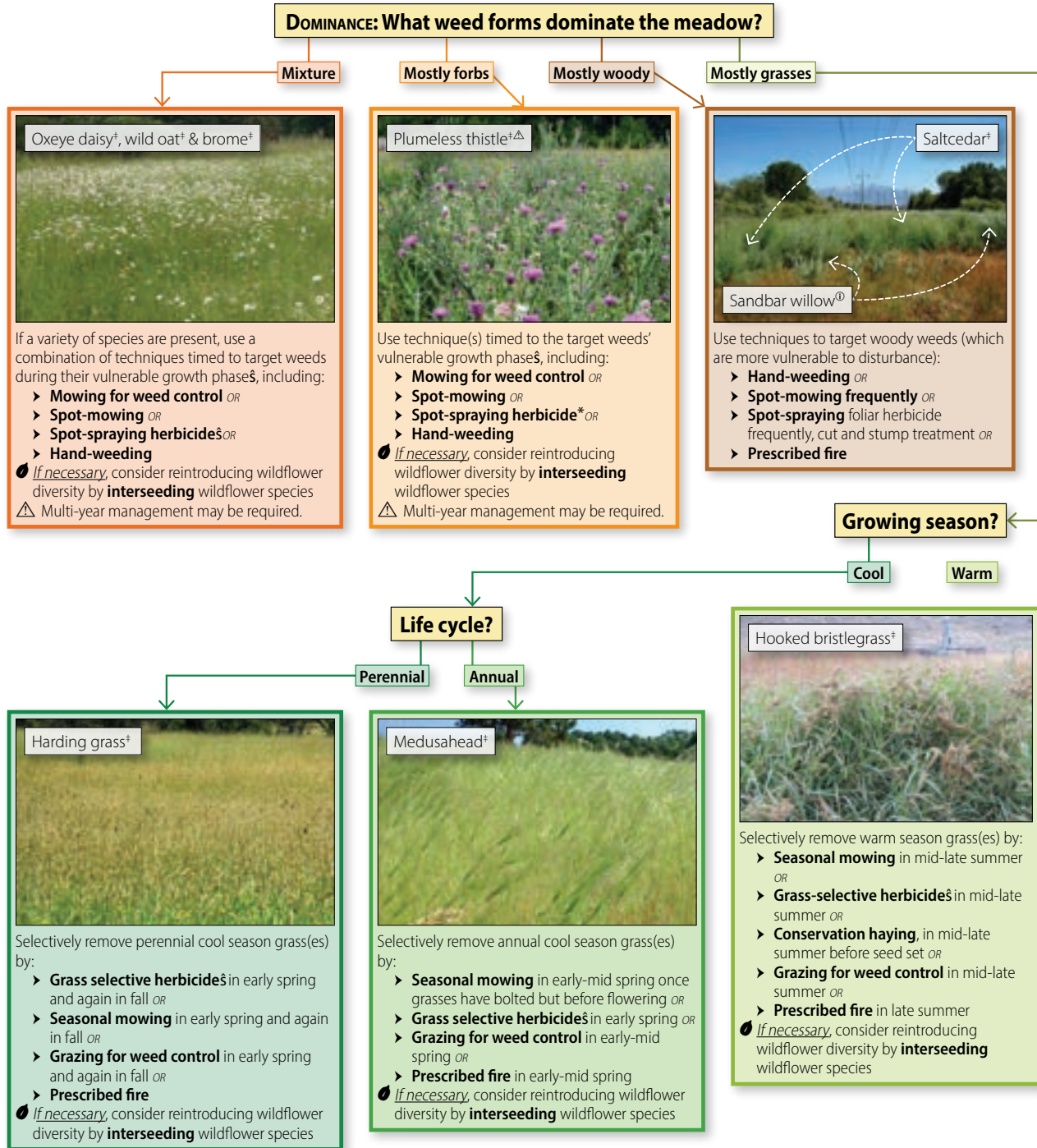



FIGURE 5.5: Follow up monitoring and assessment is critical to successfully managing wildflower plantings over the long term.

Recording Management Practices

Each wildflower planting is different and therefore responds differently to management actions. It is important to track the success of the techniques used (see *Pollinator Habitat Management Log*). If undesirable conditions persist in spite of management, then we recommend re-evaluating the technique used and either altering the timing or trying a different method. Continued monitoring will inform management and assist in the decision-making process.



FIGURE 5.6: Example Pollinator Habitat Management Log

Example **POLLINATOR HABITAT MANAGEMENT LOG**



Keeping track of management techniques helps assess effectiveness of timing and method, allowing for improved implementation in future years.

STEP 1—Print copies of this form in advance
(www.xerces.org/habitat-assessment-guides)

STEP 2—Site Name: Oregon Meadow

STEP 3—Management Practices Record

Record all management techniques used. Be sure to include the timing of the action so if it is not effective management can be adjusted in the future. In addition, record the intended goal for the management (for example, "to reduce or eradicate Harding grass from the meadow").

NOTE: Before implementing techniques the following year, be sure to evaluate whether the technique utilized met the intended goal. If not, adapt the existing technique (e.g., different timing and/or frequency) or trial a new one.

BEFORE IMPLEMENTATION				AFTER IMPLEMENTATION				
#	MANAGEMENT TECHNIQUES LOG			EFFICACY ASSESSMENT				
1	YEAR:	2015	MONTH(S):	JUN + NOV	EVALUATION DATE(S):	02/15/16	TECHNIQUE SUCCESSFUL?	Y / <input checked="" type="radio"/> N
	TECHNIQUE PLANNED:	Sprayed grass-selective herbicide			NOTES:	Abundance of non-native grasses increased		
	INTENDED GOAL:	Decrease non-native grass cover, specifically harding grass + wild oat			SUGGESTED CHANGES/NEXT STEPS:	Spot-spray more frequently, starting in early spring to target during active growth		
2	YEAR:	2016	MONTH(S):	MAR, JUN, AUG + NOV	EVALUATION DATE(S):	11/25/16	TECHNIQUE SUCCESSFUL?	<input checked="" type="radio"/> Y / N
	TECHNIQUE PLANNED:	Repeatedly spot-spray grass-selective herbicide, starting in early spring			NOTES:	Reduced non-native cover so both target species were rare.		
	INTENDED GOAL:	Decrease non-native grass cover, specifically harding grass + wild oat			SUGGESTED CHANGES/NEXT STEPS:	None		
3	YEAR:	2016	MONTH(S):	OCT + NOV	EVALUATION DATE(S):		TECHNIQUE SUCCESSFUL?	Y / N
	TECHNIQUE PLANNED:	Interseeded site in fall with globe gilia + bigleaf lupine			NOTES:			
	INTENDED GOAL:	Increase abundance of declining spring/ early summer wildflower species			SUGGESTED CHANGES/NEXT STEPS:			
	YEAR:		MONTH(S):		EVALUATION DATE(S):		TECHNIQUE SUCCESSFUL?	Y / N
	TECHNIQUE PLANNED:				NOTES:			
	INTENDED GOAL:				SUGGESTED CHANGES/NEXT STEPS:			

Print copies of this and other forms at: www.xerces.org/habitat-assessment-guides. See Appendix B for a list of the available forms.

6

Management is a Moving Target

Pollinator habitat is a dynamic living system that changes based on weather conditions and past management actions. Weed populations that have previously been controlled can re-emerge as issues in wet years or if management events were not properly timed (See *Case Study #2: Pennsylvania Apple Orchard*). Sometimes this requires re-evaluation of management techniques. As you learn the principles of habitat management described in this guide, you will become more comfortable adapting and modifying these practices to improve your pollinator habitat. The results may work well, or it may be time to go back to the drawing board. We continually fine-tune our management actions with the goal of achieving the best results. After a few years of monitoring and managing, it will likely get easier to fine tune timing and treatments, and ultimately increase the health and longevity of your pollinator habitat.

Remember that follow up monitoring and assessment is critical. Checking up on the impact of a management action, and the conditions it fosters, is key to maximizing planting success. It is easier and more cost-effective to do annual maintenance than to re-start an entire project every few years. After a year or two of monitoring, checking up on the status of the pollinator habitat will become a more rapid process as familiarity with desirable and unwanted species increases (See *Case Study #1: Oregon Blueberry Farm*). In addition, implementation of specific management techniques should also become easier. Once the desired conditions are created and wildflower species have a strong foothold (usually five years post-establishment), monitoring and management activities can decrease.

We recommend not only recording which management actions you use, but also whether they were successful. If the condition targeted was unaffected, alter the technique by changing timing, coupling it with another strategy, or taking an entirely new approach (see *Case Study #3: California Almond Orchard*). If new undesirable conditions arise, consider altering the technique or substituting it for a different one. When a management strategy is effective, however, implement it in the same way until conditions appear to change.

This guide represents a starting point for assessing and managing site conditions. Over time, a site and its unique needs will become familiar, and it will become more intuitive and efficient to recognize shifting conditions and implement techniques to optimize pollinator habitat.



This section provides real world examples of management used in wildflower habitat in three different regions: the Pacific Northwest, California, and the Mid-Atlantic states. The case studies illustrate different techniques that can be implemented with varying intensities and combinations. All of these meadows contain a high diversity of bloom, indicating that management actions continue to be successful over time.

1 OREGON BLUEBERRY FARM: *Selectively Removing Non-Native Weeds*

This ½ acre wildflower planting was initiated in 2012 alongside a conventionally managed blueberry field. Weeds were managed chemically prior to seeding with native wildflowers. Not all weedy species were eradicated; therefore, some unwanted species have persisted over time. No native bunchgrasses were included in the seed mix because the farmer wanted to retain grass-selective herbicides as a treatment option to combat the non-native grasses prevalent throughout the farm, which posed a high threat of reinvasion.

Many native wildflower species have thrived in the site, including farewell-to-spring (*Clarkia amoena*) (FIGURES 7.1–2), an annual that vigorously re-seeds itself. Other species never established, necessitating interseeding in 2014 and 2015 to fill in gaps in bloom early and late in the year—including lupine (*Lupinus* spp.), California poppy (*Eschscholzia californica*), and gumplant (*Grindelia* spp.).

FIGURE 7.1: While some species, like California poppy and lupine, thrived in the planting early—shown in May 2013—additional interseeding was required to fill gaps in bloom where other species failed to establish (shown in August 2013).





FIGURE 7.2: Now a flourishing wildflower meadow, the planting supports abundant blooms year after year, thanks to a fall mow once a year, twice annual spraying with grass-selective herbicide, and targeted dead-heading to remove individual weeds, like salsify, invading a site otherwise dominated by farewell-to-spring (shown in July 2014).

Non-native cool season grasses have continued to be a major problem, despite annual spraying with a grass-selective herbicide. Other persistent weeds including Western salsify (*Tragopogon dubius*) and Queen Anne’s lace (*Daucus carota*)—circled in white—are hand-weeded or dead-headed once a year to prevent spread into crop fields. The site is mowed annually in the fall to prevent Himalayan blackberry (*Rubus armeniacus*) from establishing. Despite continued issues with weeds present at low levels, the management actions and interseeding have been highly successful and the habitat continues to contain high-performing wildflowers that re-seed year after year.

2 PENNSYLVANIA APPLE ORCHARD: *Managing Aggressive Weeds During Establishment*

This one-acre pollinator meadow, located adjacent to an apple orchard, was first seeded with perennial wildflowers in 2011. Prior to planting, the site had very high weed pressure, including field bindweed (*Convolvulus* spp.), knapweed (*Centaurea* spp.), and thistle (*Cirsium* spp.) (Figure 7.2—September 2013). These species tend to thrive in open, cultivated ground and soil rich in nitrogen (i.e., typical conditions found in gardens and farms). Although the site was mowed and tilled prior to seeding, weeds were not eradicated. In addition, perennial wildflowers are often slower to establish than annual weeds, even though perennials are persistent once established. This combination

FIGURE 7.3: Bindweed (circled) initially covered a large portion of the meadow, mounding up on top of other weedy species as well as desirable wildflower species like asters and goldenrod—which made managing the site without harming the wildflowers more difficult.

FIGURE 7.4: By April 2015, native wildflowers—including wild bergamot (*Monarda fistulosa*) and purple coneflower (*Echinacea purpurea*)—have rebounded in the site, thanks to a combination of aggressive weed control measures, monitoring, and interseeding.



of slow wildflower establishment and inadequate site preparation allowed weeds to outcompete the wildflower seedlings, quickly leading to a weed-dominated planting. Despite this high weed pressure, some desirable plants like goldenrod (*Solidago* spp.) and asters (*Symphyotrichum* spp.) were still found in high abundance. Because of this mix of desirable and undesirable plants, starting over did not seem necessary. As an important side note, we do not recommend mowing and tillage as adequate preparation for weedy sites.

To achieve the goal of restoring diversity and function, a combination of weed control and interseeding were used. The site was flail-mowed several times in 2013 to remove as much weedy vegetation and litter as possible to promote good seed-soil contact in preparation for a fall dormant seeding. Care was taken during site preparation to disturb the soil as little as possible to avoid bringing up dormant weed seeds, which would likely cause additional weed problems in the future. Due to an unusually early snowfall event, seeding was delayed until early spring 2014, as the planting area was not accessible to planting equipment due to wet soil conditions. Note: If fall dormant seeding is delayed until spring and the seed mix has already been obtained, be sure to store the seed in an airtight container in a cool location (e.g., unheated shed or barn). Another option is to consider snow seeding (see *Snow Seeding*, p. 26). The site was interseeded at a half rate of 30 seeds/ft² (compared to the typical recommended seeding rate for wildflower meadows of 60 seeds/ft²).

Wildflowers slowly reestablished in small patches, but aggressive management was still required to continue to control weeds. Canada thistle was spot-treated with herbicide just as it was going to flower. Large patches of bindweed also received targeted spot-treatment with herbicides using a backpack sprayer. Smaller patches of bindweed required a different control method because some of the dense vines were tangled around desirable wildflowers that would also be killed if contacted by herbicide. For these smaller patches, bindweed was cut close to the ground by hand or by using a string trimmer so that the desirable plants were less disturbed. In addition, portions of the site containing poison ivy (*Toxicodendron radicans*), knapweed, fleabane (*Erigeron* spp.), plantain (*Plantago* spp.), and Queen Anne's lace were spot-mowed as needed. By April 2015, a diversity of wildflowers occupied a large portion of the site (Figure 7.2, right); however, the site will be monitored and managed to maintain a diversity of wildflower and bloom times to support apple pollinators before and after apple tree bloom.

3 CALIFORNIA ALMOND ORCHARD: *Balancing Wildflowers with Native Bunch Grasses*

This ½ acre pollinator habitat project was initiated in 2010. It is bordered by commercial almond orchards, partially restored native grasslands, chaparral, and degraded grasslands. Prior to the 2010 planting, the site was dominated by exotic annual grasses and invasive broadleaf weeds. The original planting consisted of both native forbs and native grasses. While native bunch grasses, such as purple needle grass (*Stipa pulchra*), thrived in the site (shown right, June 2013), wildflower establishment was poor. Therefore, in 2013, the landowners began managing the meadow to achieve a balance of native grasses and wildflower cover with a 50:50 ratio. The low initial wildflower establishment indicated that the existing seed bank





FIGURE 7.5: The site was mowed and shallowly disked (top) before wildflowers were planted using a native seed drill in November 2013 (bottom).



was likely insufficient to reach the desired condition through management alone, therefore, a decision was made to interseed the area with a diverse mix of native wildflowers.

To prepare for seeding, the area was mowed and shallowly disked in the fall of 2013. Seed was sown at a rate of approximately 50 seeds/ft², using a native seed drill on ½ the field (Figure 7.3) and a manual seed slinger on the other half, to test the effectiveness of different seeding methods. A ring-roller was used to push the seed down into the soil on the portion of the field that was seeded using the seed-slinger. In the end, there was no noticeable difference in wildflower establishment between the sections seeded with different equipment.

Despite a multi-year drought that impeded seed germination, the current wildflower cover in the site has improved—approximately 30:70 forb:grass ratio (Figure 7.6). Management of the site since interseeding has consisted of mowing the perimeter to prevent weed encroachment and annual fall mowing to prevent litter build-up and open up areas for new wildflower germination. There has been some encroachment of cool-season, exotic, annual grasses. If these grasses persist, they will be managed with a high mow early in the spring, carefully timed to cut the grass before it goes to seed. Because the exotic grass germinates very early, it is usually taller than the native vegetation in early spring. This allows for the mower blade to be set so that it cuts the weedy grass species without harming the native grasses and wildflowers germinating underneath.

FIGURE 7.6: In June of 2013, the site was dominated by *Stipa pulchra*, with little wildflower cover (previous page). The interseeding successfully increased native wildflower cover without reducing the abundance of native bunch grasses (below).



40

Maintaining Diverse Stands of Wildflowers Planted for Pollinators



BLOOM

Additional Resources

Seed Saving

Collecting and Seed Storage. (Ladybird Johnson Wildflower Center)

www.wildflower.org/howto/show.php?id=8&frontpage

Drying, Cleaning and Storing Prairie Seed. (Tallgrass Prairie Center)

www.tallgrassprairiecenter.org/sites/default/files/pictures/techguide2_dryingcleaning_2015_web.pdf

Eckberg, J., J. Hopwood, and E. Lee-Mader. 2016. *Expanding Pollinator Habitat on Farms: Collecting and Using Your Own Wildflower Seed*. 12 pp. Portland, OR: The Xerces Society for Invertebrate Conservation.

www.xerces.org/collecting-wildflower-seed

Seed Collecting from Tallgrass Prairies. (Tallgrass Prairie Center)

www.tallgrassprairiecenter.org/sites/default/files/pictures/techguide1_seedcollecting_2015_web.pdf

Tchida, C. *Collecting Wildflower and Prairie Seeds*. (University of Minnesota Extension: Sustainable Urban Landscape Information Series.)

www.extension.umn.edu/garden/landscaping/implement/wildflower.htm

Wall, M., and J. MacDonald (photographer). 2009. *Processing Seeds of California Native Plants for Conservation, Storage, and Restoration*. CD. Claremont: Rancho Santa Ana Botanic Garden

www.amazon.com/gp/product/0981971709

Prescribed Fire

Resource Center: Prescribed Fire (eXtension.org)

http://articles.extension.org/prescribed_fire

Prescribed Fire Equipment (eXtension.org)

<http://tinyurl.com/RxFireEquip>

Re-starting Habitat

Jordan, S. F., J. K. Cruz, K. Gill, J. Hopwood, J. Fowler, E. Lee-Mäder, and M. Vaughan. 2016. *Wildflower Establishment: Organic Site Preparation Methods*. 44 pp. Portland, OR: The Xerces Society for Invertebrate Conservation.

www.xerces.org/organic-wildflower-establishment

Habitat Installation Guides (The Xerces Society)

These regional installation guides provide in-depth guidance on installing and maintaining wildflower meadows or hedgerows as pollinator habitat, including example seed mixes and recommended plants.

www.xerces.org/pollinator-habitat-installation-guides

Interseeding

Williams, D., J. Eckberg, J. Hopwood, R. Powers, M. Vaughan, K. Jokela, S. Foltz Jordan, and E. Lee-Mader. 2018. *Interseeding Wildflowers to Diversify Grasslands for Pollinators: Guidance for the Great Plains and Midwest Regions*. 36 pp. Portland, OR: The Xerces Society for Invertebrate Conservation.

<https://xerces.org/interseeding-grasslands-for-pollinators/>

FIGURE 8.1: Collecting wild seeds—such as milkweed (*Asclepias* spp.)—can be a good way to obtain locally-adapted ecotypes.



Weed Management

- DiTomaso, J. M., et al. 2013. *Weed Control in Natural Areas in the Western United States*. Davis: UC Weed Research and Information Center.
- New Jersey Invasive Species Strike Team
Species List with Control Recommendations (Includes Target, Watch and Widespread Species): www.njisst.org/documents/SpeciesListandControlRecommendations15.xlsx
- Radosevich, S., R., J. S. Holt, C. M. Ghera. 2007. *Ecology of Weeds and Invasive Plants: Relationship to Agriculture and Natural Resource Management*. John Wiley and Sons.
- Weed Research and Information Center. (UC Cooperative Extension and Agricultural Experiment Station) <http://wric.ucdavis.edu/>
- DiTomaso, J. M., G. B. Kyser, and M. J. Pitcairn. 2006. *Yellow starthistle management guide*. 78 pp. Berkeley: California Invasive Plant Council. www.cal-ipc.org/ip/management/pdf/YSTMgmtweb.pdf

Grazing

- Helzer, C. 2011. *Patch-Burn Grazing for Biological Diversity*. The Nature Conservancy. <https://prairienebraska.files.wordpress.com/2011/05/patch-burning-for-biodiversity.pdf>
- Weir, J.R., S.D. Fuhlendorf, D.M. Engle, T.G. Bidwell, D.C. Cummings, D. Elmore, R.F. Limb, B. W. Allred, J.D. Scasta, and S.L. Winter. 2013. *Patch Burning: Integrating Fire and Grazing to Promote Heterogeneity*. Oklahoma Cooperative Extension Service and Oklahoma State University. <http://pods.dasnr.okstate.edu/docushare/dsweb/Get/Document-4677/E-998survey2013.pdf>
- Database of Plants Poisonous to Livestock (Cornell University) <http://poisonousplants.ansci.cornell.edu/php/plants.php>
- Range and Pasture Technical Resources (USDA–NRCS) www.tinyurl.com/NRCS-Grazing-Lands
- Resource value of plants in the Southern Plains (Oklahoma State University Extension Service) www.okrangelandswest.okstate.edu/files/grazing%20management%20pdfs/F-2872.pdf
- NRCS Field Offices www.nrcs.usda.gov/wps/portal/nrcs/main/national/contact/local/
Visit your local field office to find more information on desirable species for grazing.

Weed Identification

- Introduced, Invasive, and Noxious Plants <https://plants.usda.gov/java/noxiousDriver>
Federal and state lists noxious, invasive, and introduced plants, with links to more information.
- National Invasive Species Information Center (United States Department of Agriculture) www.invasivespeciesinfo.gov/
This website has a compilation of fact sheets and identification guides for invasive plants.
- New Jersey Invasive Species Strike Team
Info Center: www.njisst.org/index.asp
- Weed Identification Tool. (University of Wisconsin–Madison Cooperative Extension) www.weedid.wisc.edu/weedid.php
- Weed Image Search. (Weed Science Society of America) <http://wssa.net/wssa/weed/weed-identification/>
- Weed Research and Information Center. (UC Cooperative Extension and Agricultural Experiment Station) <http://wric.ucdavis.edu/>
- Uva, R. H., J. C. Neal, and J. M. DiTomaso. 1997. *Weeds of the Northeast*. 408 pp. Ithaca, New York: Cornell University Press.
- Stubbendieck, J., M. Coffin, and L. M. Landholt. 2003. *Weeds of the Great Plains*. 605 pp. Lincoln: Nebraska Department of Agriculture.
- Parkinson, H., J. Mangold, and F. Menalled. 2015. *Weed Seedling Identification Guide for Montana and the Northern Great Plains*. 164 pp. Bozeman: Montana State University Extension. <http://store.msuextension.org/publications/AgandNaturalResources/EB0215.pdf>
- Whitson, T. D., L. C. Burrill, S. A. Dewey, D.W. Cudney, B.E. Nelson, R. D. Lee, and R. Parker. 2001. *Weeds of the West*. 630 pp. Laramie: University of Wyoming.















Herbicides

- Best Management Practices for Wildlands Stewardship www.cal-ipc.org/ip/management/BMPs/BMPHerbicide.pdf
- Bee precaution pesticide rating (University of California Integrated Pest Management [UC–IPM]) www2.ipm.ucan.edu/beeprcaution/#
- Johansen, E., L. A. Hooven, and R. R. Sagili. 2013. *How to Reduce Bee Poisoning from Pesticides*. 35 pp. Corvallis: Oregon State University. <https://catalog.extension.oregonstate.edu/sites/catalog/files/project/pdf/pnw591.pdf>





Appendix A: Regional Differences Table







There are regional differences in the management strategies used to maintain diverse stands of wildflowers. This table is meant to be a general guide to the timing and types of management strategies used within each region. There will be variation within a region based on elevation, local site conditions, and other factors.

REGION		CALIFORNIA	PACIFIC NORTHWEST
Technique	Timing		
VEGETATION MONITORING ¹	EVERY 2–3 WKS	▶ JAN–JUN	▶ FEB–SEP
	ONCE A MONTH	▶ JUL–DEC	☒
MOWING FOR DIVERSITY	SEASONAL 	▶ OCT	▶ AUG / SEP (fall mow for woody plant control).
	ROTATIONAL 	▶ OCT	▶ Can be used in areas without Himalayan blackberry (which should be mowed every fall).
MOWING FOR WEED CONTROL ²	DURING ESTABLISHMENT	▶ EARLY SPRING: High mow to target early-germinating, tall weeds (e.g., annual grasses and malva/ mustard).	☒ Not commonly used in this region.
	AFTER ESTABLISHMENT	☒ MID-SUMMER: High mow to target warm season weeds (e.g., prickly lettuce).	
GRASS-SELECTIVE HERBICIDES ³		▶ MID–DEC: Begin mid-month and continue throughout winter and spring as needed. Most commonly used to manage cool-season grasses; most effective when grasses are small (<6" tall); may need multiple treatments.	 * SPRING–SUMMER: Commonly applied a few times.  * MID- to LATE-AUG: Final spray  
			⚠ Aggressive species may need multiple applications.
CONSERVATION HAYING ⁴ 		☒ Not commonly used in this region.	
PRESCRIBED FIRE ⁵		▶ FALL burn to clear litter. ▶ EARLY SPRING burn to manage cool-season weeds.	▶ AUG 15 TH –OCT 15 TH
GRAZING		▶ Defer grazing for first year to promote good establishment. After that, with appropriate stocking rates and / or rotation, grazing can be compatible with diversity in any season.	▶ Not very common in this region; cattle preferred in grassland habitats; goats for steep hillsides, particularly along waterways.
INTERSEEDING	FALL-SEEDED	 OCT–NOV: Seed with fall rains.	 SEP 15 TH –OCT 15 TH : After the rains and before a frost; or,
	SPRING-SEEDED	☒	 MAR
PLUGS AND BARE ROOT PLANTING ⁶		 MID–OCT–MID–DEC, with irrigation available at the time of planting.  MID–DEC–EARLY FEB	▶ SEP 15 TH –OCT 15 TH : Plant plugs or bare root transplants after the rains and before frosts; or,  SPRING: Plugs usually require irrigation for the first season.
IRRIGATION		▶ APR–OCT for the first 2–3 years during normal rainfall years, or more frequently as as needed during drought years. ▶ Required for transplants; may be necessary in seeded areas during drought.	▶ Not required unless planting in the spring or during multi-year droughts.
STARTING OVER	BEGIN SITE PREP	▶ JAN (unless solarizing, which can be undertaken later in the spring).	▶ FEB / MAR
	SEED SITE	 OCT–NOV: Plant with fall rains.	 OCT–NOV: Dormant seed.

KEY:

- ☒ Not applicable.
-  **REMINDER:** Avoid using management technique during nesting season for ground-nesting birds.
-  **REMINDER:** Avoid or postpone management technique when wet conditions are predicted, such as spraying herbicides—to avoid movement of herbicides off target—or seeding during excessively wet conditions.
- ⚠ **WARNING**—Additional action may be needed.
-  Seed (or interseed) site.

ADDITIONAL INFORMATION:

1. **VEGETATION MONITORING**—Add [MAR] APR and [NOV] OCT for invasive cool-season grass scouting (); first several hard frosts (.
2. **MOWING FOR WEED CONTROL**—During establishment (~years 1–2); after establishment (years 2–3+). **Reminder:** Keep fire safety guidelines in mind when mowing in arid regions (.
3. **GRASS-SELECTIVE HERBICIDES**—Target applications during active growth of the dominant grass weeds on site: cool season grasses (); warm-season grasses (). **Reminder:** Avoid use or use carefully in plantings that contain desirable native grasses.
4. **CONSERVATION HAYING**—To support plant diversity, aim to hay at different times every year.
5. **PRESCRIBED FIRE**—When possible, avoid burning more than 1/3 of an area in a given year.
6. **PLUGS AND BARE ROOT PLANTING**—Plant plug transplants (); plant bare root transplants (.

Appendix A: Regional Differences Table *continued*

REGION		SOUTHWEST	MOUNTAIN REGION
Technique	Timing	Low [High] Elevations	
VEGETATION MONITORING ¹	EVERY 2–3 WKS	▶ FEB–JUN [APR–JUL]	▶ APR–SEP
	ONCE A MONTH	▶ JUL–JAN [AUG–MAR]	☒
MOWING FOR DIVERSITY	SEASONAL 🌿	▶ NOV [SEP / OCT]	▶ OCT
	ROTATIONAL 🌿	▶ NOV [SEP / OCT]	▶ OCT
MOWING FOR WEED CONTROL ²	DURING ESTABLISHMENT	☒ Not a commonly used technique in this region.	▶ Mow to 6–8" when weeds are 12–15" to allow sunlight to reach seedlings, yet avoid smothering them.
	AFTER ESTABLISHMENT		▶ Mow one to several times when a significant amount of priority weeds are close to flowering (prior to seed set).
GRASS-SELECTIVE HERBICIDES ³		🌿 WINTER [SPRING] and again in FALL, shortly before dormancy. 🌿 MID-SUMMER	🌿 SPRING and again in FALL, shortly before dormancy. 🌿 MID-SUMMER
⚠ Aggressive species may need multiple applications.			
CONSERVATION HAYING ⁴ 🌿		☒ Not commonly used in this region.	
PRESCRIBED FIRE ⁵		▶ FALL burn to clear litter. ▶ EARLY SPRING burn to manage weeds.	▶ YEAR-ROUND: Burn at various times throughout the year. ▶ SUMMER or FALL burns may be better for maintaining wildflowers.
GRAZING		▶ Defer grazing for first year to promote good establishment. After that, with appropriate stocking rates and / or rotation, grazing can be compatible with diversity in any season.	▶ Defer grazing for first year to promote good establishment. After that, with appropriate stocking rates and / or rotation, grazing can be compatible with diversity in any season.
INTERSEEDING	FALL-SEEDED	🌱 NOV / DEC [SEP/OCT]: Sow seed with fall rains.	🌱 OCT / NOV; or,
	SPRING-SEEDED	☒	🌱 FEB / MAR
PLUGS AND BARE ROOT PLANTING ⁶		🌱 NOV / DEC [SEP / OCT], with irrigation available. 🌱 DEC / JAN [OCT / NOV]	🌱 APR / MAY or late AUG / SEP: Plant as early as possible to catch spring rains. 🌱 DORMANT SEASON ▶ NOTE: May require irrigation for the first season.
IRRIGATION		▶ Irrigation is required for transplants for the first 2–3 years, and maybe be required for seeded areas during drought.	▶ Irrigation is required for transplants for the first 2–3 years.
STARTING OVER	BEGIN SITE PREP	▶ FEB [APR]	▶ APR
	SEED SITE	🌱 FALL or EARLY SPRING	🌱 DORMANT SEASON (fall) or in early spring to take advantage of spring rains.

KEY:

- ☒ Not applicable.
- 🌿 **REMINDER:** Avoid using management technique during nesting season for ground-nesting birds.
- 🌧 **REMINDER:** Avoid or postpone management technique when wet conditions are predicted, such as spraying herbicides—to avoid movement of herbicides off target—or seeding during excessively wet conditions.
- ⚠ **WARNING:** Additional action may be needed.
- 🌱 Seed (or interseed) site.

ADDITIONAL INFORMATION:

1. **VEGETATION MONITORING**—Add [MAR] APR and [NOV] OCT for invasive cool-season grass scouting (🌿); first several hard frosts (❄).
2. **MOWING FOR WEED CONTROL**—During establishment (~years 1–2); after establishment (years 2–3+). **Reminder:** Keep fire safety guidelines in mind when mowing in arid regions (☒).
3. **GRASS-SELECTIVE HERBICIDES**—Target applications during active growth of the dominant grass weeds on site: cool season grasses (🌿); warm-season grasses (🌿). **Reminder:** Avoid use or use carefully in plantings that contain desirable native grasses.
4. **CONSERVATION HAYING**—To support plant diversity, aim to hay at different times every year.
5. **PRESCRIBED FIRE**—When possible, avoid burning more than 1/3 of an area in a given year.
6. **PLUGS AND BARE ROOT PLANTING**—Plant plug transplants (🌱); plant bare root transplants (🌱).



GREAT PLAINS	MIDWEST
South [North]	
	☒
🏠 APR–OCT [MAY–SEP]	✿ MAY–SEP
<ul style="list-style-type: none"> ▶ Rotational mowing preferred. ▶ If mowing annually is required: NOV [OCT]. 	<ul style="list-style-type: none"> ▶ LATE JUN: Mow to reduce dominance of native warm-season grasses. ▶ AFTER OCT 1ST: Mow to increase availability of sunlight for spring wildflowers.
<ul style="list-style-type: none"> ▶ Avoid mowing site more than once every three years. 	<ul style="list-style-type: none"> ▶ Avoid mowing site more than once every three years; avoid periods of peak bloom (e.g., July 1ST–Sept. 30TH).
<ul style="list-style-type: none"> ▶ MAY–AUG [JUN–SEP]: Mow to 6–8" when weeds are 12–15" to allow sunlight to reach seedlings. 	<ul style="list-style-type: none"> ▶ JUN–SEP: Mow to 6–8" when weeds are 12–15" to allow sunlight to reach seedlings and avoid thick litter accumulation.
<ul style="list-style-type: none"> ▶ SUMMER: Mow one to several times when a significant amount of priority weeds are close to flowering (prior to seed set). 	<ul style="list-style-type: none"> ▶ SUMMER: Mow one to several times when a significant amount of priority weeds are close to flowering (prior to seed set).
<ul style="list-style-type: none"> ▶ SPRING and again in FALL, shortly before dormancy. 	<ul style="list-style-type: none"> ▶ SPRING: Spray cool-season grasses in spring, or in FALL shortly before dormancy.
🌿 MID-SUMMER	
⚠ Aggressive species may need multiple applications.	
<ul style="list-style-type: none"> ▶ OCT: Fall hay. 	<ul style="list-style-type: none"> ▶ AFTER OCT 1ST (ideally) or after peak bloom. However, haying may need to occur earlier if the nutritional quality of the hay is a concern.
<ul style="list-style-type: none"> ▶ YEAR-ROUND: Burn at various times throughout the year. ▶ SUMMER or FALL burns may be better for maintaining wildflowers. 	<ul style="list-style-type: none"> ▶ DORMANT SEASON: In fall after vegetation has dried out; or, ▶ SPRING: Before significant green-up. Spring burns can help to control cool-season grasses. Hotter burns with longer duration will manage against tree and shrub weeds.
<ul style="list-style-type: none"> ▶ With appropriate stocking rates, grazing is compatible with diversity in any season under a variety of grazing systems including patch burn, rotational, or continuous. When grazing during growing season, know the palatability of your wildflowers. 	<ul style="list-style-type: none"> ▶ With appropriate stocking rates, grazing is compatible with encouraging plant diversity by reducing litter build-up, reducing grass dominance through patch-burn grazing or keeping woody species under control. ▶ If grazing for weed control, graze during peak growth of target weed before it flowers.
<ul style="list-style-type: none"> ▶ DEC–FEB [NOV–FEB]: Dormant season interseed. 	<ul style="list-style-type: none"> ▶ FALL or DORMANT SEASON: Fall or snow seed.
	☒
<ul style="list-style-type: none"> ▶ OCT 15TH–JAN 1ST [SEP]; or, ▶ MAR 1ST–APR 15TH [APR / MAY] ▶ NOTE: May require irrigation for the first season. 	<ul style="list-style-type: none"> ▶ EARLY FALL or SPRING: Plugs may require irrigation if soils are dry and/or rain does not follow planting event.
<ul style="list-style-type: none"> ▶ If dry or drought year, irrigate recent plug and bare root plantings. 	<ul style="list-style-type: none"> ▶ Generally not required unless plug planting is subjected to unusually dry conditions.
<ul style="list-style-type: none"> ▶ FEB–APR [MAR–MAY]: Begin full season of site prep followed by DORMANT seeding. If existing vegetation is aggressive, sod-forming grasses, two growing seasons of site prep may be necessary. 	<ul style="list-style-type: none"> ▶ MAY
<ul style="list-style-type: none"> ▶ DORMANT SEASON (fall) or in early spring to take advantage of spring rains. 	<ul style="list-style-type: none"> ▶ OCT–NOV (or DORMANT SEASON): Seed habitat; or, ▶ Put (back) into other production to manage weed seed bank (1+ years).

Notes:

Appendix A: Regional Differences Table *continued*

REGION		NEW ENGLAND	MID-ATLANTIC
TECHNIQUE	TIMING		
VEGETATION MONITORING ¹	EVERY 2–3 WKS	☒	▶ MAR–OCT
	ONCE A MONTH	▶ MAY–OCT / NOV	☒
MOWING FOR DIVERSITY	SEASONAL 🌿	▶ OCT / NOV: Mow after first several hard frosts, but before permanent snow cover.	▶ FEB–MAR ▶ SEP–OCT 🌿 Rotational patch mowing preferred. Do not mow vegetation shorter than 4".
	ROTATIONAL 🌿		
MOWING FOR WEED CONTROL ²	DURING ESTABLISHMENT	▶ Mow to 6–8" when weeds are 12–15" to allow sunlight to reach seedlings, kill annual weeds, halt weed seed dispersal, and avoid thick litter accumulation.	
	AFTER ESTABLISHMENT	Dependent on weed growth.	
GRASS-SELECTIVE HERBICIDES ³		🌿🌿 SPRING: Spray cool-season grasses in spring, or in FALL shortly before dormancy.	🌿🌿 EARLY SPRING or MID-FALL: Spray for cool-season grasses.
⚠️ Aggressive species may need multiple applications.			
CONSERVATION HAYING ⁴ 🌿		☒ Not commonly used in this region.	
PRESCRIBED FIRE ⁵		▶ NOV: Before snow cover; or, ▶ MAR–MAY: Before green-up, but after snowmelt (varies by year). 🌿 SPRING burns can help to control cool-season grasses.	▶ FEB 15 TH –MAR 15 TH
GRAZING		☒ Not commonly used in this region.	
INTERSEEDING	FALL-SEEDED	🌿 OCT / NOV: After first several hard frosts, but before permanent snow cover.	🌿 NOV 15 TH –DEC 15 TH : Before first hard-frost; or, 🌿 MAR–APR 🌿
	SPRING-SEEDED		
PLUGS AND BARE ROOT PLANTING ⁶		▶ MAY / JUN: Plant as early as possible to catch spring rains. ▶ Additional irrigation may be required during the first year of establishment, especially during dry years.	🌿 NOV 1 ST –DEC 15 TH or MAR 1 ST –MAY 15 TH 🌿 OCT 15 TH –DEC 15 TH or MAR 1 ST –MAY 31 ST : Plant in the fall before frost date or in spring after last hard frost. Planted plugs usually require irrigation for the first season.
IRRIGATION		▶ For spring seeded plots, irrigate during establishment year so that irrigation plus rainfall totals ~1" per week. Fall seeded plots should not require irrigation excepting very dry years, or excessively well drained soils.	▶ Plugs or bare roots may require supplemental irrigation until established. Wildflower habitat established by seed does not typically require irrigation in this region.
STARTING OVER	BEGIN SITE PREP	▶ SPRING: As soon as soil can be worked (typically MAY–JUN).	▶ SPRING: As soon as soil can be worked.
	SEED SITE	🌿 OCT / NOV: After frost but before permanent snow cover.	🌿 NOV / DEC: Dormant seeding after frost but before ground freezes or permanent snow cover 🌿

KEY:

- ☒ Not applicable.
- 🌿 **REMINDER:** Avoid using management technique during nesting season for ground-nesting birds.
- 🌿 **REMINDER:** Avoid or postpone management technique when wet conditions are predicted, such as spraying herbicides—to avoid movement of herbicides off target—or seeding during excessively wet conditions.
- ⚠️ **WARNING:** Additional action may be needed.
- 🌿 Seed (or interseed) site.

ADDITIONAL INFORMATION:

1. **VEGETATION MONITORING**—Add [MAR] APR and [NOV] OCT for invasive cool-season grass scouting (🌿); first several hard frosts (🌿).
2. **MOWING FOR WEED CONTROL**—During establishment (~years 1–2); after establishment (years 2–3+).
Reminder: Keep fire safety guidelines in mind when mowing in arid regions (☒).
3. **GRASS-SELECTIVE HERBICIDES**—Target applications during active growth of the dominant grass weeds on site: cool season grasses (🌿); warm-season grasses (🌿). **Reminder:** Avoid use or use carefully in plantings that contain desirable native grasses.
4. **CONSERVATION HAYING**—To support plant diversity, aim to hay at different times every year.
5. **PRESCRIBED FIRE**—When possible, avoid burning more than 1/3 of an area in a given year.
6. **PLUGS AND BARE ROOT PLANTING**—Plant plug transplants (🌿); plant bare root transplants (🌿).



SOUTHEAST	
▶ JAN / FEB–NOV	☒
▶ Rotational mowing preferred. NOTE: If mowing annually is required, break up area into three or more sections: 1. SPRING / 2. MID-SUMMER 🌿 / 3. FALL or WINTER	
▶ Mow to 6–8" when weeds are 12–15" to allow sunlight to reach seedlings, kill annual weeds, halt weed seed dispersal, and avoid thick litter accumulation.	
Dependent on weed growth.	
🌿* EARLY SPRING or MID-FALL: Spray for cool-season grasses.	
⚠️ Aggressive species may need multiple applications.	
▶ To support plant diversity over time, change up haying times.	
▶ YEAR-ROUND: Can occur throughout the year.	
▶ Cattle and other grazers like horses, goats, and sheep help maintain diversity in some areas, particularly balds and boggy sites.	
🌿 DORMANT SEASON: After the first frost; or before the last frost.	
☒	
🌿* DORMANT SEASON plantings are recommended, so that roots can develop when there is likely to be adequate moisture.	
🌿* SPRING. Still may require irrigation.	
▶ Plugs or bare roots may require supplemental irrigation until established. Wildflower habitat established by seed does not typically require irrigation in this region.	
▶ Smother cropping — SPRING: begin site prep using tillage when plants have grown a few inches. SUMMER–FALL: smother crops for fall planting.	
▶ Solarization —can be started in SPRING or FALL .	
🌿 LATE FALL	



FIGURE A1: Interseeding a site dominated with native grasses, using a native seed drill.

Notes:

Appendix B: Project Planning Forms

These forms were designed as tools to assist you with monitoring wildflower diversity and longevity on a site and planning habitat management. You can download them as printable PDFs at: <http://xerces.org/habitat-assessment-guides/>

Installation Plan

Example on page 3.

The form is titled "POLLINATOR HABITAT INSTALLATION PLAN" and includes sections for "Habitat Installation Record", "Site Preparation & Habitat Installation", and "Plant Selection". It features a table for recording site details and plant species.

Monitoring Form

Example on page 7.

The form is titled "POLLINATOR HABITAT MONITORING FORM" and includes sections for "Monitoring Record", "Site Details", and "Species Diversity Agendas". It features a large table for recording monitoring data and species diversity.

Evaluation Form

Example on page 11.

The form is titled "POLLINATOR HABITAT EVALUATION FORM" and includes sections for "Habitat Monitoring Record", "Site Details", and "Species Diversity Agendas". It features a table for recording evaluation data and species diversity.

Management Log

Example on page 35.

The form is titled "POLLINATOR HABITAT MANAGEMENT LOG" and includes sections for "Management Record", "Site Details", and "Species Diversity Agendas". It features a table for recording management activities and species diversity.

Appendix C: Additional Acknowledgments

Photographs

We are grateful to the photographers for allowing us to use their wonderful photographs. The copyright for all photographs is retained by the photographers. None of the photographs may be reproduced without permission from the photographer:

Bear Paw Battlefield, National Parks Service [[flickr.com/bearpaw](https://www.flickr.com/photos/bearpaw/)]—Figure 4.6: Glacier Exotic Plant Team spot-spraying Canada thistle (*Cirsium arvense*) and bindweed (*Convolvulus* spp.).

Tony Frates [[flickr.com/tonyfrates](https://www.flickr.com/photos/tonyfrates/)]—Decision Tree #3: saltcedar (*Tamarix chinensis*) and sandbar willow (*Salix exigua*) taking over a frequently-mowed site.

Kimberly Gallagher: Figure 7.4.

Chris Hoving [[flickr.com/pcrucifer](https://www.flickr.com/photos/pcrucifer/)]—Figure 4.9: Prescribed burn in Newaygo county for Karner blue butterfly (*Plebejus melissa samuelis*) habitat.

Matt Lavin [[flickr.com/plantdiversity](https://www.flickr.com/photos/plantdiversity/)]—Decision Tree #1: Low value native grass; Decision Tree #3: Cheat grass (*Bromus tectorum*).

Mark Mathosian [[flickr.com/markgregory](https://www.flickr.com/photos/markgregory/)]—Figure 4.1: Florida burrowing owl (*Athene cunicularia floridana*).

Justin Meissen [[flickr.com/40855483@N00](https://www.flickr.com/photos/40855483@N00/)]—Figure 4.6 (right): Spot-spraying herbicide on woody weeds.

Montana Fish, Wildlife, and Parks—Decision Tree #3: Hooked bristlegrass (*Setaria verticillata*).

Oregon State University [[flickr.com/oregonstateuniversity](https://www.flickr.com/photos/oregonstateuniversity/)]: Decision Tree #3: Medusahead (*Taeniatherum caput-medusae*).

Harry Rose [[flickr.com/macleaygrassman](https://www.flickr.com/photos/macleaygrassman/)]—Decision Tree #3: Harding grass (*Phalaris aquatica*).

Tina Shaw, USFWS Midwest Region [[flickr.com/usfwsmidwest](https://www.flickr.com/photos/usfwsmidwest/)]—Figure 7.1: Collecting milkweed (*Asclepias* spp.) seeds.

Lan Shen, Houston NPAT [[flickr.com/hnpat](https://www.flickr.com/photos/hnpat/)]—Decision Tree #2: Mostly woody weeds.

Ken Slade [[flickr.com/TexasEagle](https://www.flickr.com/photos/TexasEagle/)]—Decision Tree #2:

Patchy weeds.

Claudia Street, Glenn County RCD—Figure 4.2: Tarweed (*Grindelia* spp.) seedlings seven days post-mowing.

Stephen Thomforde, Great River Greening—Figure 4.8: Conservation haying.

Sandor Weisz [[flickr.com/santheo](https://www.flickr.com/photos/santheo/)]—Figure 4.5: Hand-weeding at Meadowbrook Farm.

Dave Williams—Figure 4.4: Using a string-trimmer for targeting weeds between wildflowers.

The Xerces Society / Nancy Lee Adamson—Figure 5.1.

The Xerces Society / Jessa Kay Cruz—Cover (*front*); Figures 3.3, 4.3, 4.7, 4.13, 5.2, 5.3; Decision Tree #1: Lacy phacelia (*Phacelia tanacetifolia*), distinct patches, intermixed, key planted species missing, gaps in bloom; Decision Tree #2: Prickly lettuce (*Lactuca serriola*) & Radish (*Raphanus* spp.); Figures 7.2–3; A1.

The Xerces Society / Sarah Foltz Jordan—Figures 1.1, 2.1, 3.4, 4.8, 4.10, 4.12A & 4.11B, 4.14, 4.15; Decision Tree #1: Common yarrow (*Achillea millefolium*), April 2015, May 2016; Decision Tree #3: Plumeless thistle (*Carduus acanthoides*).

The Xerces Society / Kelly Gill—Decision Tree #2: Mostly Grasses; Figure 7.5–6.

The Xerces Society / Jennifer Hopwood—Cover (*back*); Figures 3.5, 4.11; Decision Tree #1: Low-moderate value wildflower.

The Xerces Society / Eric Lee-Mäder—Figure 7.1.

The Xerces Society / Hillary Sardiñas—Decision Tree #3: Mixed weedy forbs and grasses.

The Xerces Society / Mace Vaughan—Figure 6.1.



Hunt's bumble bee (*Bombus huntii*) on lacy phacelia (*Phacelia tanacetifolia*) in Montana pollinator planting. (Photograph by Jennifer Hopwood, The Xerces Society.)



628 NE Broadway, Suite 200, Portland, OR 97232
Tel (855) 232-6639 Fax (503) 233-6794
www.xerces.org

Regional offices from coast to coast.

16-028_02



BLOOM

This page intentionally left blank.

COMMUNITY POLLINATOR MASTER PLAN

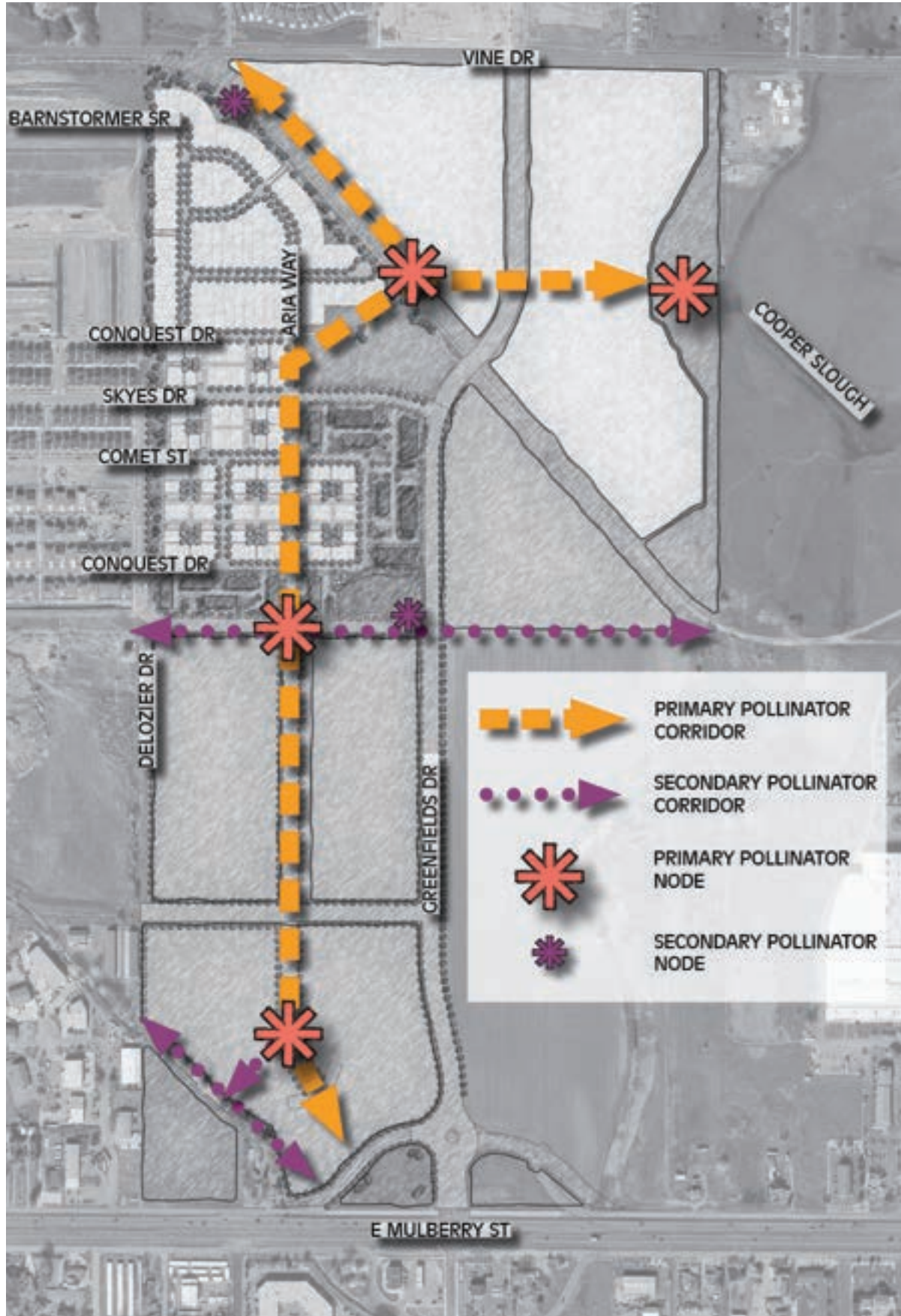

RESOURCES

There are a variety of resources providing useful information on the establishment of pollinator habitat and corridors. Following best practices as prescribed by these resources is recommended to maximize the value of pollinator plantings:

City of Fort Collins Natural Areas

www.fcgov.com/naturalareas/

City of Fort Collins Nature in the City

www.fcgov.com/natureinthecity/

Plant Select

www.plantselect.org

Pollinator Partnership

www.pollinator.org

Xerces Society for Invertebrate Conservation

www.xerces.org

IMPLEMENTATION AND MAINTENANCE

Most landscape contractors do not have experience in the establishment and maintenance of plant materials that will create year-round habitat. Many common landscape maintenance practices are detrimental to pollinators and to the successful establishment of flowering plants. As perennial and woody plants evolve and mature, they can experience a decline in abundance and diversity. Providing nesting and overwintering habitat is a critical component to establishing successful populations of pollinators. A successfully managed pollinator program can also benefit songbirds and a balanced urban ecosystem.

The below documents, provided earlier in this document, were created by the Xerces Society to provide direction on the successful establishment, maintenance, and monitoring of pollinator habitat:

Nesting and Overwintering Habitat

(found on pages 100-113)

Maintaining Diverse Stands of Wildflowers Planted for Pollinators

(found on pages 114-168)

POLLINATOR NODE TYPICALS

Nodes should include a combination of bloom time, color and plant species to support a diverse group of pollinators. Nodes can also be grouped to support specific landscape aesthetic based on color palette, height and scale. Typical suggested massings can be used as a single element for secondary nodes or expanded and combined to create a larger primary node or landscape focal point.

Note: Node examples are provided for reference only and are not all-encompassing. Additional pollinator species can be added as needed to support diversity within the overall community and within individual filings to support variation in bloom color and bloom time. Recommended plant palette and plant codes follow this page. In addition to plantings, bee hotels, and other artificial habitats can be added at key nodes to further diversity pollinator resources.

Bloom Throughout Growing Season

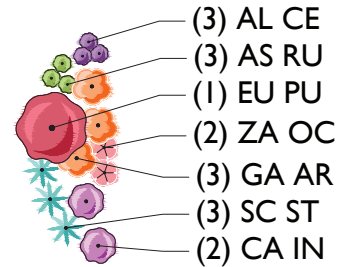
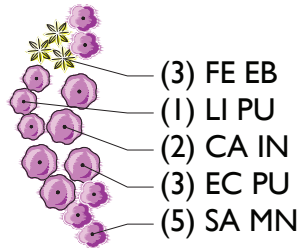
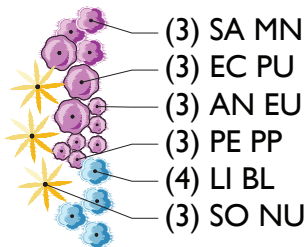
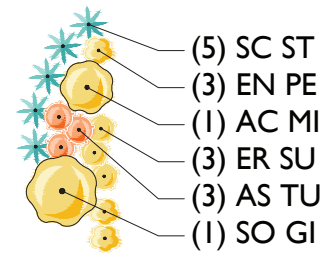
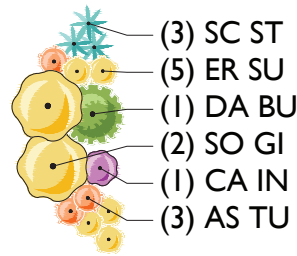
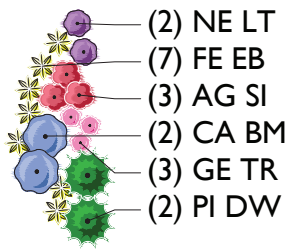

Seasonal Bloom

Spring

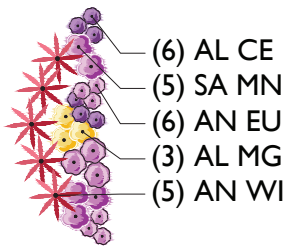

Summer

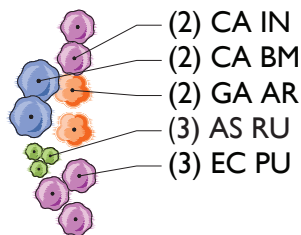

Fall

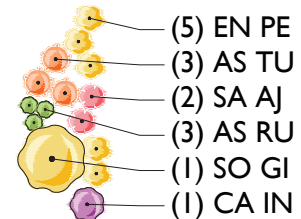

BLOOM

RECOMMENDED PLANT PALETTE



Caryopteris x clandonensis
'Blue Mist'
Blue Mist Bluebeard
CA BM



Daphne x burkwoodii
'Carol Mackie'
Carol Mackie Daphne
DA BU



Pinus edulis
Dwarf Pinion Pine
PI DW



Andropogon gerardii
'Windwalker'
Windwalker Big Bluestem
AN WI



Helictorichon semoervirens
Blue Oat Grass
HE SE



Schizachyrium scoparium
'Standing Ovation'
Standing Ovation Bluestem
Grass



Sorghas trumnutans
Indian Grass
SO NU



Achillea 'Moonshine'
Moonshine Yarrow
AC MI



Agastache cana 'Sinning'
Sonoran Sunset Hyssop
AG SI



Allium cernuum
Nodding Onion
AL CE



Alyssum Montanum
'MountainGold'
Creeping Basket of Gold
AL MG



Anemone pulsatilla
Pasqueflower
AN EU



Asclepias speciosa
Showy Milkweed
AS RU



Asclpias tuberosa
Butterflyweed
AS TU



Callirhoe involucrata
Prairie Wine Cups
CA IN

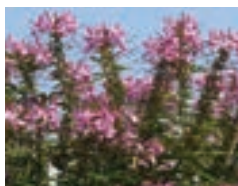

Cleome serrulata
Rocky Mountain Bee Plant
VI BV



Echinacea purpurea
Purple Coneflower
EC PU

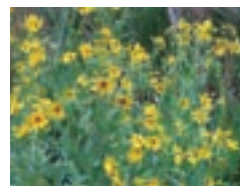

Engelmannia peristena
Engelmann's Daisy
EN PE



Eriogonum umbellatum
Sulflower Buckwheat
ER SU



Eutrochium purpureum
Sweet Joe Pye Weed
EU PU



Gaillardia aristata
Native Blanket Flower
GA AR



Geum triflorum
Prairie Smoke
GE TR



Liatris punctata
Dotted Gayfeather
LI PU

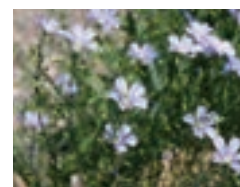

Linum lewisii 'Blue Glax'
Blue Flax
LI BL



Nepeta psfike 'Little Trudy'
Little Trudy Catmint
NE LT



Penstemon mexicali
'Pike's Peak Purple'
Pikes Peak Purple Penstemon
PE PP



Salvia x sylvestris 'May Night'
May Night Salvia
SA MN



Sedum spectabile 'Autumn
Joy'
Autumn Joy Sedum
SA AJ



Solidago gigantea
Giant Goldenrod
SO GI



Zauscheneria garrettii
'Orange Carpet'
Creeping Hummingbird
Trumpet
ZA OC

Note: The palette provided is not all-encompassing. Additional pollinator species can be added as needed to support diversity within Bloom and individual fillings, and as appropriate for varied water requirements and micro-climates.

This page intentionally left blank.



This page intentionally left blank.